

# 1418 N4 Series Freestanding Enclosures - NEMA 4

## Single Door

Industrial Enclosures

Freestanding Enclosures



**Panel  
Sold  
Separately**



### Application

- Designed to house electrical, electronic, hydraulic or pneumatic controls with provision for panel mounting or rack mounting of equipment.
- Provides protection where equipment may be hosed down or otherwise be very wet, or in specific applications where corrosion is a serious problem.
- A variety of inner panels, rack mounting rails and swing out frames are available to provide flexibility in mounting arrangements.

### Standards

- UL 508 Type 3R, 4 and 12
- CSA Type 3R, 4 and 12
- **Complies with**
  - NEMA Type 3R, 4, 12 and 13
  - IEC 60529, IP54

### Construction

- Formed 12 gauge steel.
- Smooth, continuously welded seams without knockouts, cutouts or holes.
- Lifting eyes provide for easy enclosure handling.
- Doors are supported with heavy gauge continuous hinges.
- Doors are secured with heavy duty stainless steel clamps.
- Oil resistant gaskets are permanently secured and mechanically retained.
- Mounting channels are welded on the inside of the enclosure for mounting of optional inner panels or rack equipment rails.
- A grounding stud is provided in the enclosure and a bonding stud is provided on the door.

### Finish

- Cover and enclosure are finished in recoatable smooth ANSI 61 gray powder coating on the outside, with white powder coating on the inside.
- Optional inner panels are finished in white powder coating.

### Accessories

- Air conditioners...*see page 387-405*
- Breather kits...*see page 423*
- Door stop kits...*see page 447*
- Drip shield kits...*see page 447*
- Filter fans...*see page 408-413*
- Gland plates...*see page 441*
- Heaters...*see page 418-420*
- Inner Panels...*see page 48*
- Light kit...*see page 447*
- Panel rails...*see page 49*
- Swing frame...*see page 49*
- Thermostats...*see page 421*
- Window kits...*see page 444*

# 1418 N4 Series Freestanding Enclosures - NEMA 4

Single Door

Industrial Enclosures Freestanding Enclosures

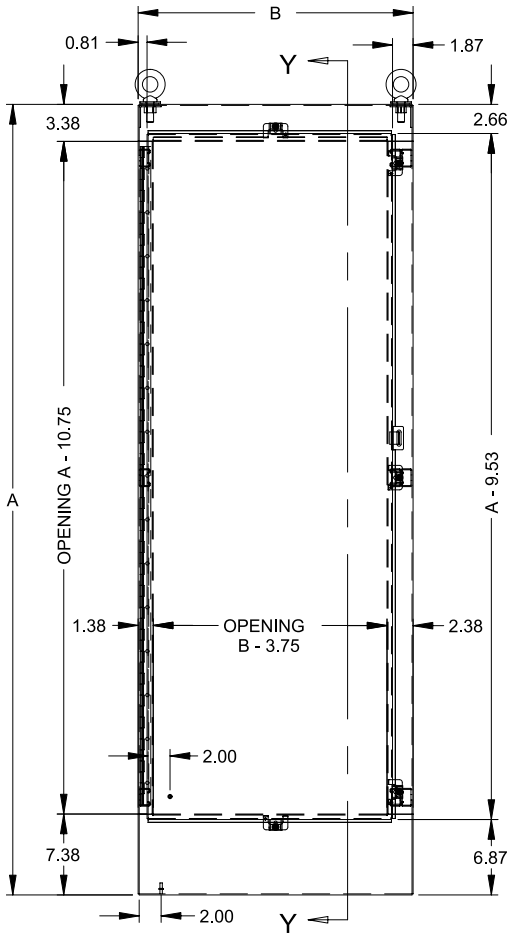

**Front View**

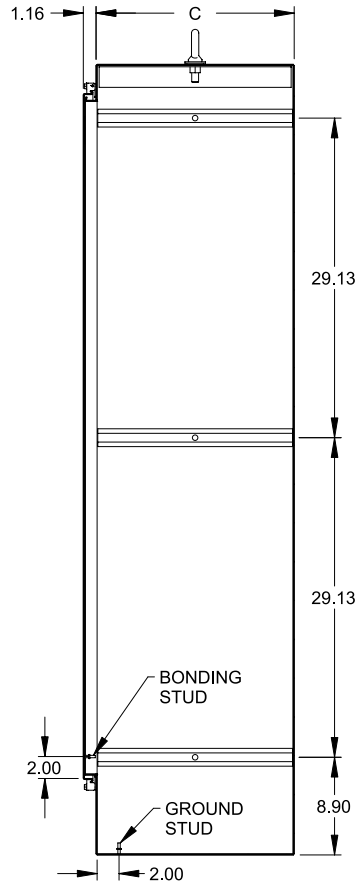

**Section Y-Y**

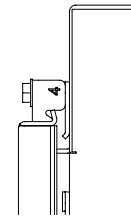

**Top Lip Detail**

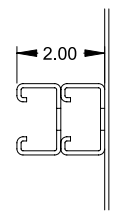

**Strut Detail - Right Side**

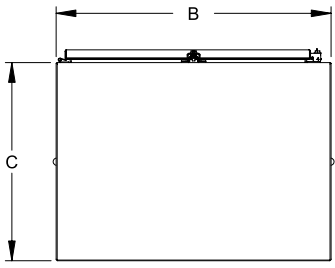

**Bottom View**

Part No.	A	B	C	Optional Full Panel <sup>1</sup>	Ship Wt. lbs.
1418N4W18	72.06	25.06	18.06	72WFW	290
1418N4X24	72.06	31.06	24.06	72XFW	250
1418N4Y24	72.06	37.06	24.06	72YFW	390

<sup>1</sup> Refers to Optional Full Height/Full Width Panels. Depth Panels & Half Height Width panels are also available...see page 48.