

Type 12 Mild Steel Two Door Floormount Disconnect Enclosure *2UD*

F Series

Hinge Door with Handle (Flange w/ multi-vendor cutout)

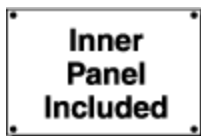

Application

- Designed to accept the following disconnect switches and circuit breakers:
 - **ABB Controls** flange mounted variable depth operating mechanisms for disconnect switches and circuit breakers.
 - **Allen Bradley** 1494V and 1494U variable depth flange mounted disconnect switches and circuit breaker mechanisms.
 - **C-H Westinghouse** Type C361 disconnect switches and operator mechanisms, and type C371 circuit breakers and circuit breaker operating mechanisms. Flex Shaft™ handle operators for circuit breakers.
 - **General Electric** Type STDA flange handles and variable depth operating mechanisms for disconnect switches and circuit breakers. Also Spectra-Flex™ cable operators for circuit breakers.
 - **Siemens I-T-E Max-Flex™** flange mounted variable depth operating handles for disconnect switches and circuit breakers.
 - **Square D** disconnect switches and circuit breakers used with Class 9422 flange mounted variable depth operating mechanisms or cable mechanisms. These enclosures will not receive Class 9422 bracket mounted disconnect devices, Class 9422TG1, or TG2 devices.
- Refer to the **Universal Disconnect Selection Guide**.

Operator Adaptor Kits

- All universal series enclosures require one adaptor kit (ordered separately) to adapt the type of disconnect and mechanism to be used.
- Each brand and type requires a different adaptor kit.
- Each kit contains an adaptor plate and master door interlocking mechanism.
- Fully detailed, illustrated instructions are included.

Standards

- UL 508A Type 12
- CSA Type 12
- **Complies with**
 - NEMA Type 12
 - IEC 60529, IP54
- Appropriate components are required to maintain these standards.

Construction

- Formed from 10 gauge steel with smooth, continuously welded seams.
- Body stiffeners are included in the larger enclosures for extra rigidity.
- Flange trough collar (FTC) around door opening excludes liquids and contaminants.
- 15" floor stands are welded to the enclosure.
- Removable doors are secured with heavy duty lift-off hinges.

- Formed 10 gauge steel inner panels are provided on collar studs.
- Panel supports are provided.
- Center post is removable, providing easy panel installation.
- Heavy duty three point latching mechanism with heavy duty roller ends is provided for ease of door closing.
- Oil resistant gaskets are permanently secured.
- The right hand door is the master door.
- Master door handle complete with screw defeater and padlock hasp.
- Slave door handle complete with padlock hasp.
- A mechanical interlock activated by the master door prevents the auxiliary door from being opened first.
- The universal flange cutout provides mounting for disconnect operators by use of the appropriate operator adaptor kit.
- A provision for mounting fluorescent lighting is provided.
- A bonding stud is provided in the door and a grounding stud is provided in the enclosure for each door.
- A literature pocket is provided.

Note

- Disconnect switches, circuit breakers and operators are not provided with the enclosure, and must be ordered separately from the manufacturer.

Finish

- Cover and enclosure are phosphatized and finished in recoatable smooth ANSI 61 gray powder coating.
- Inner panel is finished in white powder coating.

Accessories

- Flange Disconnect Operator Adaptor Kits
- Door Stop Kit
- Climate Control
- General Accessories
- Additional Inner Panels
- Window Kits
- Lighting

New and improved PDF part drawing files with more detail now available.

Click part number in table below to access PDF, DXF, and STEP files.

Part No.	Enclosure			Inner Panel	
	H	W	D	H	W
2UD605012FFT C	60.13	50.00	12.13	56.00	44.00
2UD605018FFT C	60.13	50.00	18.13	56.00	44.00
2UD606212FFT C	60.13	62.00	12.13	56.00	56.00
2UD606218FFT C	60.13	62.00	18.13	56.00	56.00
2UD726212FFT C	72.13	62.00	12.13	68.00	56.00

Part No.	Enclosure			Inner Panel	
	H	W	D	H	W
2UD726218FFT C	72.13	62.00	18.13	68.00	56.00
2UD727412FFT C	72.13	74.00	12.13	68.00	68.00
2UD727418FFT C	72.13	74.00	18.13	68.00	68.00
2UD727424FFT C	72.13	74.00	24.13	68.00	68.00

Tags: **2UD, two door, floormount, disconnect, Type 12, ABB controls, 1494V, 1494U, Allen Bradley, C361, C371, Cutler Hammer, ITE, Max Flex, Siemens, STDA, General Electric, 9422, Square D** *Data subject to change without notice.*

© 2026. Hammond Manufacturing Ltd. All rights reserved.