

# Series 2000 Modular Console System - NEMA 12, 4, 4X

## Internal Accessories

Operator Interface Enclosure

### Desk Inner Panel

- 12 gauge steel panels.
- Used in both Standard and Deep desks.
- Available in 4 widths.
- Mounts horizontally onto panel mounting studs in bottom of desk.
- Finished in white.

Part No.	Fits Console Width	Height	Width	Depth
2CWDP24	24	0.5	22	16
2CWDP36	36	0.5	34	16
2CWDP48	48	0.5	46	16
2CWDP60	60	0.5	58	16

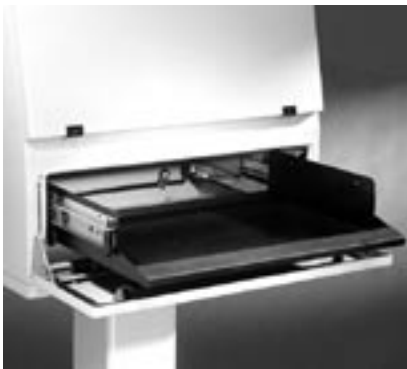

### Terminal Keyboard Shelf

- Designed specifically for use in Data Terminal.
- Sloped wrist rest provides comfort for operator.
- Locks in place when extended.
- 20" width accommodates standard width keyboards.
- Finished in textured black.
- Slides included.

Part No.	Height	Width	Depth
2CWDSR	3.88	20	15.63



### Swing Frame

- Available in 19" and 24" widths.
- Variable depth feature allows front to rear adjustment.
- Installs with either left or right hinging.
- Mounts onto Rail Support Kits (not included)...see page 269.
- Clip nuts required for mounting to punched rails...see page 277.
- Finished in textured black.



Part No.	Fits Console Unit	Fits Console Size	Panel Width	Panel Height	A	B
2CSFT19	Turrets/Terminal	24,36,48,60	19"	8U	15.75	19.28
2CSFT24	Turrets/Terminal	36,48,60	24"	8U	15.75	24.28
2CSFB19	Bases	24,36,48,60	19"	12U	22.09	19.28
2CSFB24	Bases	36,48,60	24"	12U	22.09	24.28

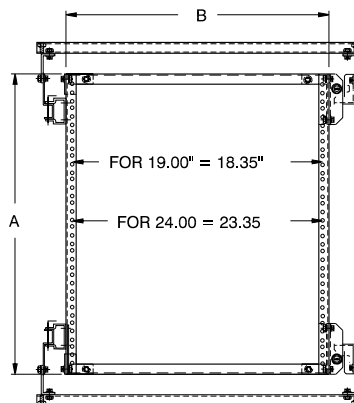

Modular Console System