

RRAL - SERIES

ASSEMBLY INSTRUCTIONS FOR ALUMINUM RELAY RACK

BUL10246
REV. A
PAGE 1 OF 1

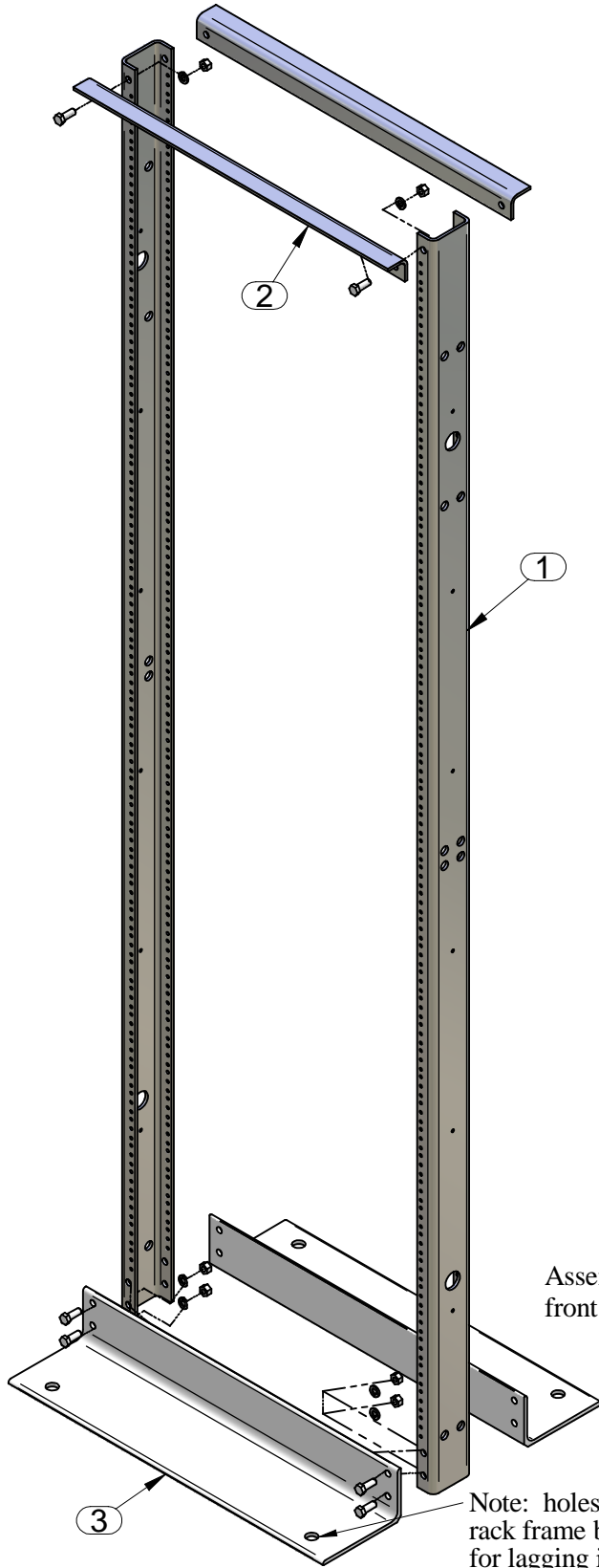

Assembly typical front and rear

Note: holes are provided in rack frame base (4 places) for lagging into floor. Lag bolts are not included

ASSEMBLY DETAIL

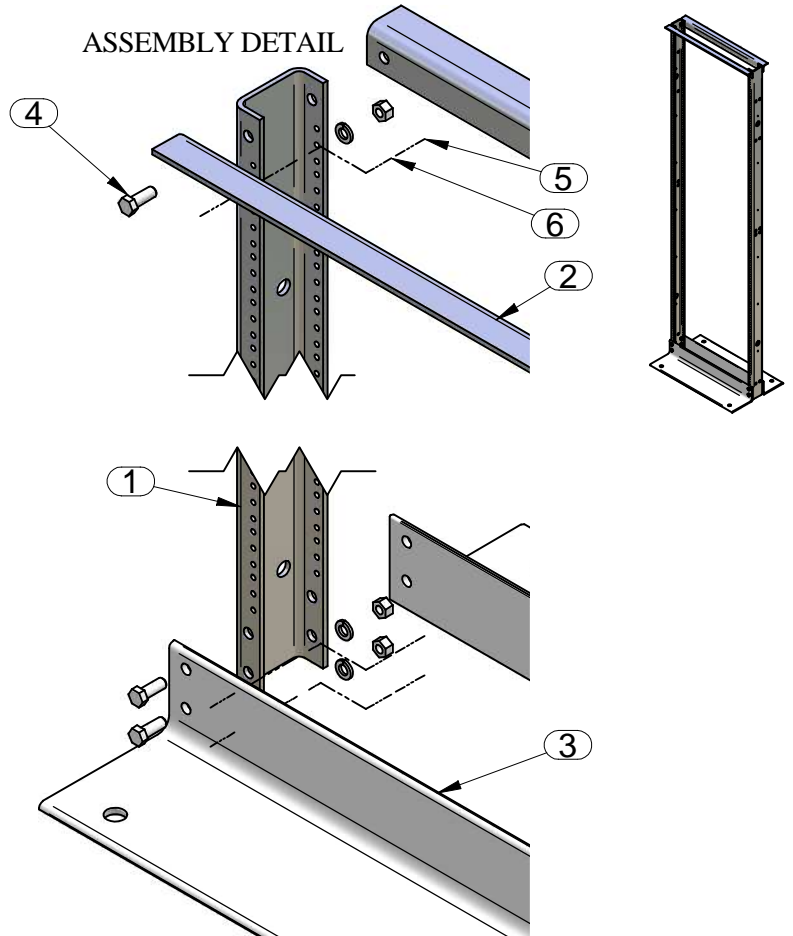

ASSEMBLY INSTRUCTIONS:

- A) Fasten the base supports (item 3) and top supports (item 2) to the frame verticals (item 1) using the 3/8 hardware (items 4, 5 & 6) supplied. See assembly detail above.
- B) Hand tighten the frame assembly. Then square the rack and tighten hardware fully.
- C) Note: Holes are provide in rack frame base (4 places) for lagging into floor. Lag bolts are not included.

PARTS LIST

ITEM No.	DESCRIPTION	QTY
1	TAPPED FRAME VERTICALS	2
2	TOP HORIZONTAL SUPPORTS	2
3	BASE SUPPORTS	2
4	3/8-16 HEX HD SCREWS	12
5	3/8-16 HEX HD NUTS	12
6	3/8 LOCK WASHERS	12
7	12-24 MOUNTING SCREWS	30

TOOL BOX



9/16" Socket Wrench



9/16" Open End Wrench



Square



visit our website @ www.hammondmfg.com