

# UHDM FLAT END PLATES

BUL10262  
REV. B

## ASSEMBLY INSTRUCTIONS FOR UHDM FLAT END PLATES, (UHDM7218EPA, UHDM8418EPA, UHDM8424EPA)

### ASSEMBLY INSTRUCTIONS

- A) CHECK THAT THE SEALING GASKET ON THE UHDM ENCLOSURE IS NOT DAMAGED. SEE CAUTION NOTE BELOW.
- B) INSTALL THE FLAT END PLATE (PART 1) AS SHOWN ONTO THE END OF THE UHDM ENCLOSURE.
- C) FINGER TIGHTEN THE NUTS AND WASHERS (PARTS 2 & 3) ONTO THE 1/4 - 20 STUDS ON THE END PLATE.
- D) TIGHTEN THE NUTS WITH A WRENCH STARTING IN THE CENTER OF THE PLATE AS INDICATED AND WORKING OUTWARDS FROM THE CENTER TOWARDS THE TOP AND BOTTOM. TORQUE HEX NUTS TO 40 - 45 IN LBS.

**NOTE:** TIGHTEN CENTER NUTS FIRST ON BOTH SIDES THEN TIGHTEN EVENLY TO THE TOP AND BOTTOM OF THE ENCLOSURE. SEE STEP D.

**CAUTION:** CHECK GASKET ON THE ENCLOSURE SURFACE FOR DAMAGE BEFORE RE-ASSEMBLY. IF THE GASKET IS CUT OR TORN, CONTACT HAMMOND MANUFACTURING FOR IMMEDIATE REPLACEMENT. SEE STEP A.

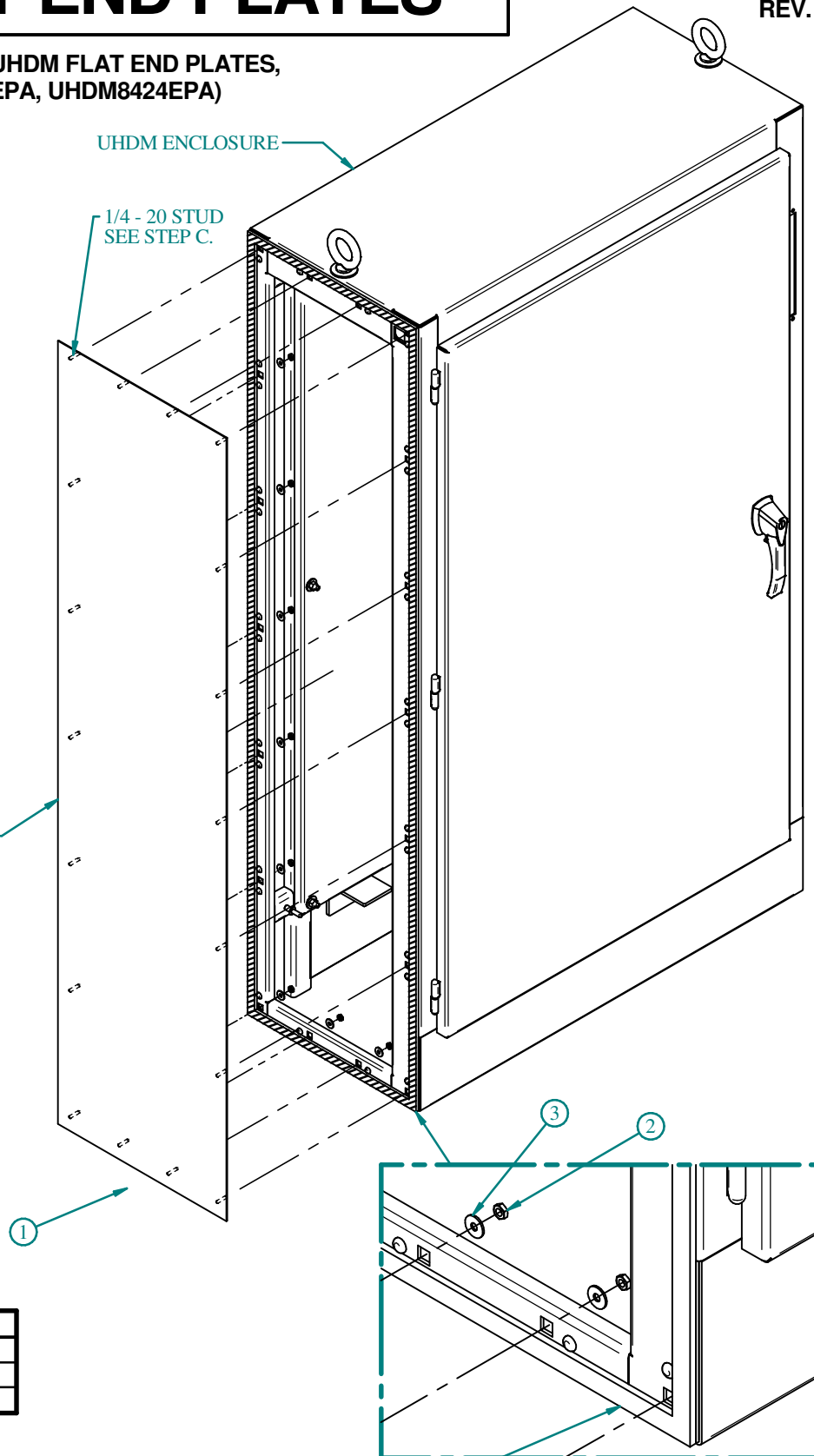

| PART # | QTY. | DESCRIPTION      |
|--------|------|------------------|
| 1      | 1    | FLAT END PLATE   |
| 2      | 18   | 1/4 - 20 HEX NUT |
| 3      | 18   | 1/4 FLAT WASHER  |

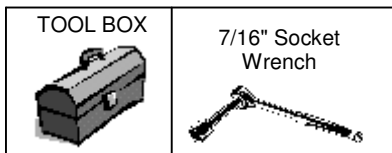

SEALING GASKET ON ENCLOSURE

**HAMMOND**  
**MANUFACTURING™**  
**ENCLOSURES**