

CGK400 SERIES

BUL10290

REV. B

ASSEMBLY INSTRUCTIONS FOR CGK400 - GROUND HARDWARE KIT

ITEM #	DESCRIPTION	QTY
1	ENCLOSURE - BODY	1
2	GROUND LUG - 2/0-14 X (7) AL/CU	1
3	WASHER FLAT #10 ZP SAE	2
4	WASHER #10 ZP INTERNAL STAR	2
5	SCREW - 10-32X5/16 PH/SL PAN TYPE F ZP	2
6	GROUND LUG - 1/0-14 X (1) AL/CU	1
7	WASHER FLAT 1/4 ZP SAE	1
8	WASHER 1/4 LOCK INTERNAL ZP	1
9	SCREW 1/4-20 X 5/8 RND SL ZP	1
10	NUT 1/4-20 KEP ZP	1
11	GRD. SYMBOL LABEL	1

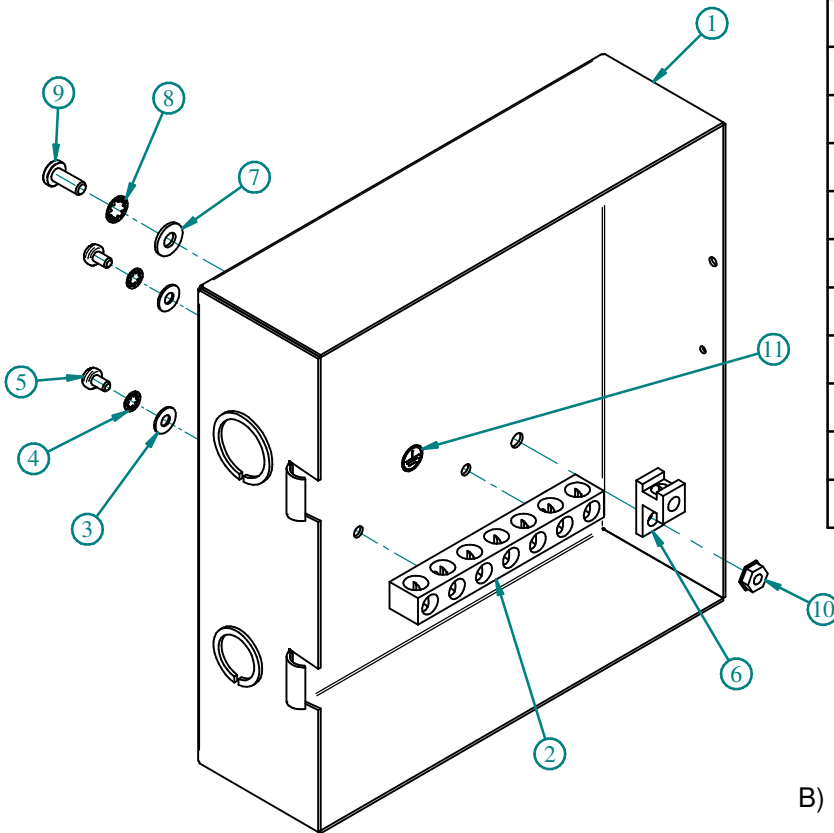

EXPLODED - ISOMETRIC VIEW

ASSEMBLY INSTRUCTIONS

- A) Locate lugs in desired locations.
- B) Measure, mark, and drill body as per drilling detail.
Drill (2) 0.218 (6mm) dia. holes and (1) 0.281 (7mm) dia. hole.
- C) Remove paint from around 0.218 (6mm) and 0.281 (7mm) dia. holes to allow for proper conductivity.
- D) Install lug (ITEM # 2) using 10-32 hardware and (ITEM # 6) using 1/4-20 hardware, as shown in the ISOMETRIC VIEW.
- E) Install grounding label as shown. (ITEM #11)

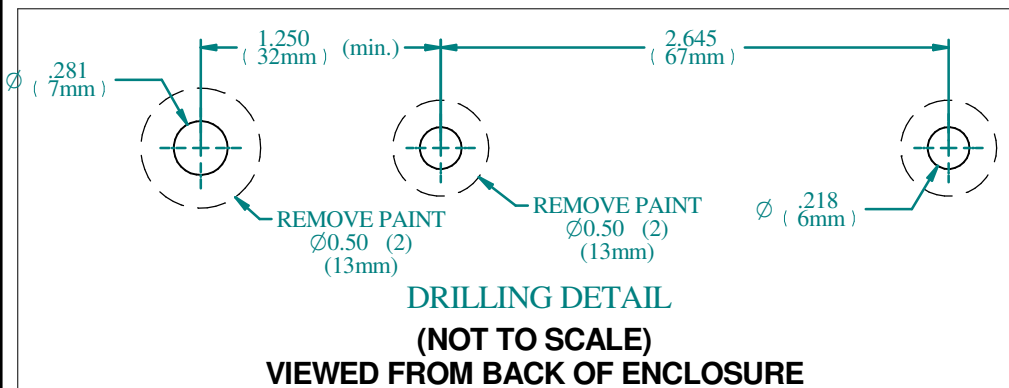

**HAMMOND
MANUFACTURING™**
ENCLOSURES
www.hammondmfg.com

