

3R - PANEL HARDWARE MOUNTING KIT (1/4 - 20)

ASSEMBLY INSTRUCTIONS FOR ASSEMBLING INNER PANEL

BUL10309
REV. B

INSTRUCTIONS

- (A) LOCATE THE FOUR DIMPLES ON THE BACK OF THE ENCLOSURE, AND DRILL 4 (0.266") HOLES AT THEIR LOCATION.
- (B) INSERT SCREW THROUGH BACK OF ENCLOSURE, AND THREAD ON STANDOFFS.
- (C) PLACE SUPPLIED WASHER ON STANDOFF, THEN INSTALL INNER PANEL.
- (D) INSTALL SECOND WASHER FOLLOWED BY THE HEXNUT.
- (E) SECURE IN PLACE.

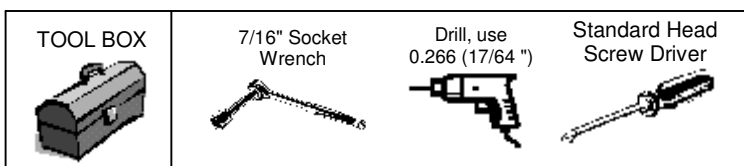
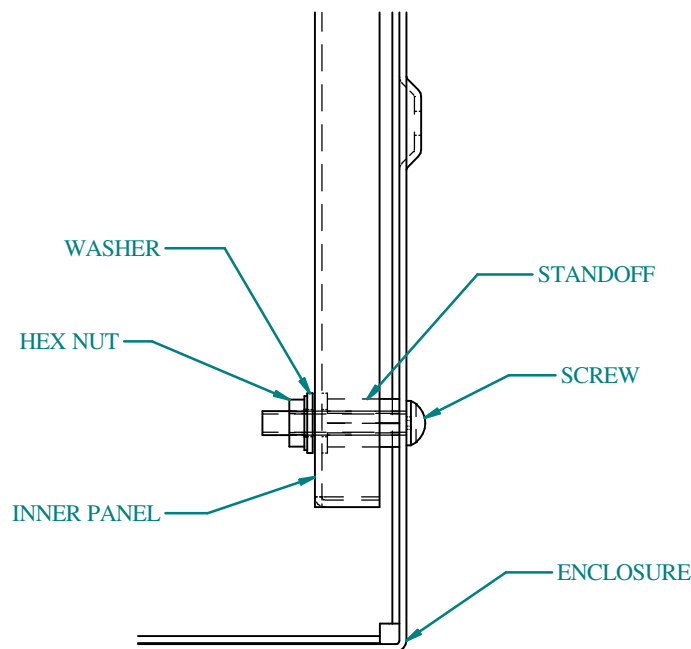

**HAMMOND
MANUFACTURING™
ENCLOSURES**