

# SPB2 SERIES

## ASSEMBLY INSTRUCTIONS FOR SWING PANEL

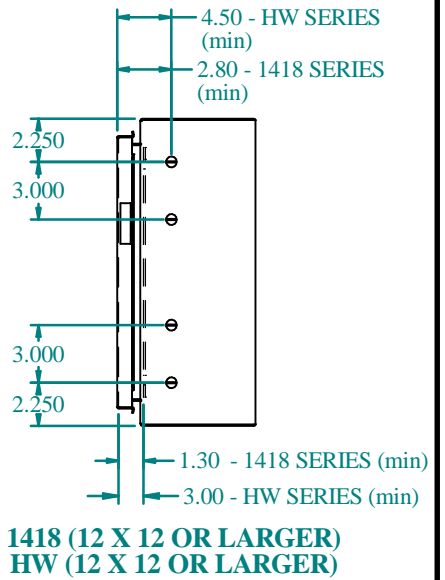
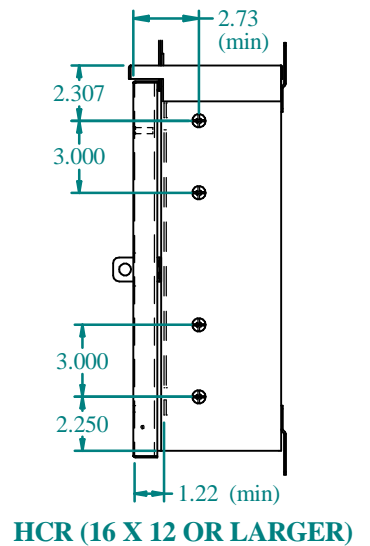
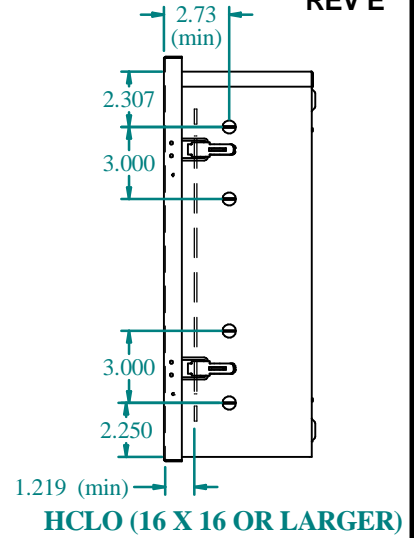
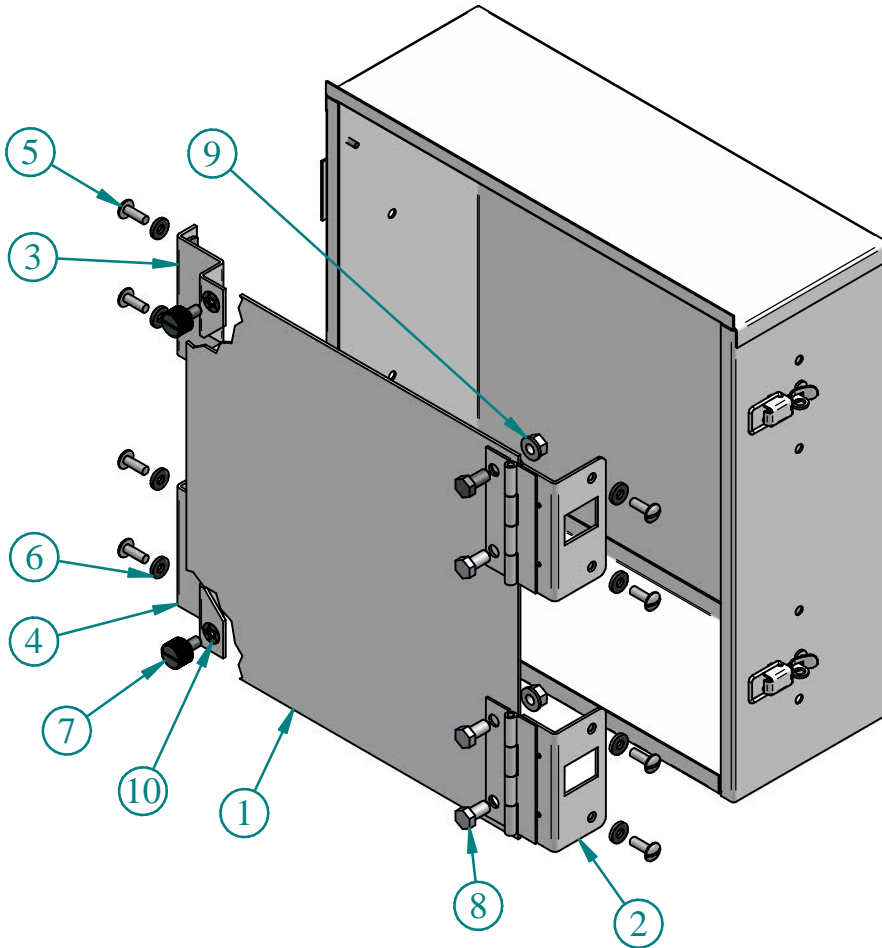

**NOTE:** - To maintain Type 12 & 4 rating, sealing washers must be used.  
 - Panels must be ordered separately.  
 - Data subject to change without notice.

**ASSEMBLY INSTRUCTIONS**

ITEM #	QTY	DESCRIPTION
1	1	SWING PANEL
2	2	HINGE BRACKET
3	1	FIXED BRACKET
4	1	FIXED BRACKET
5	8	1/4-20 SCREW
6	8	1/4" SEALING WASHER
7	2	5/16 THUMB SCREW
8	4	3/8 HEX BOLT
9	4	3/8 KEP NUT
10	2	5/16 PUSH NUT

- A) Swing panel may be hinged on either side of the enclosure. Determine mounting position and drill .281(7.1mm) Dia. holes as shown in drill detail.
- B) Mount hinges and brackets using 1/4-20 screws with supplied sealing washers. (Parts 5 and 6).
- C) Mount swing panel to hinges using two 3/8 Hex bolts and Kep nuts. (Parts 8 and 9). Make sure swing panelswings freely through the door opening.
- D) Attach Thumb screws to the panel using Pushnut. (Parts 7 and 10)
- E) Drill two .500(12.7mm) dia. holes in swing panel and install extra 3/8 Hex bolt and Kep nut (Parts 8 and 9) per hinge as shown.

