

ASSEMBLY DETAIL

Assembly typical front and rear

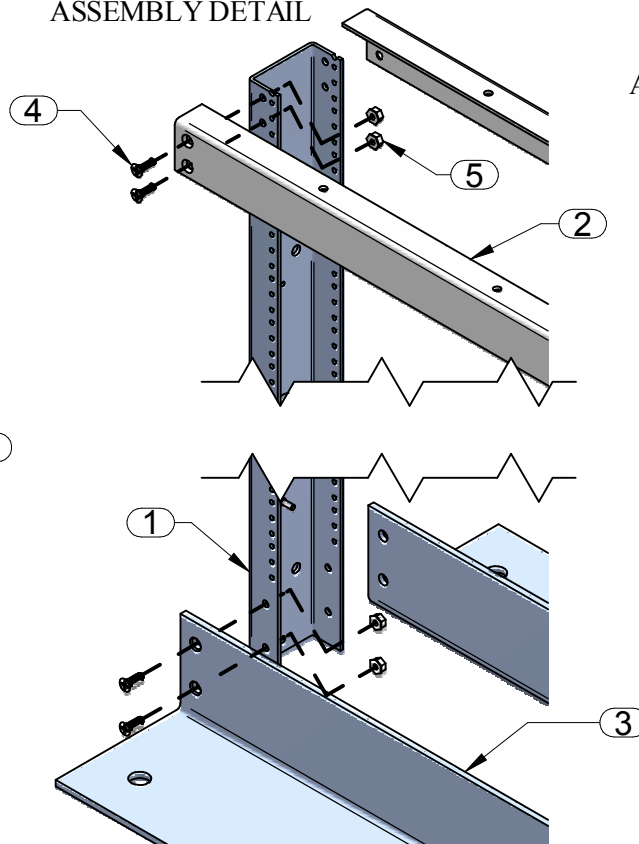
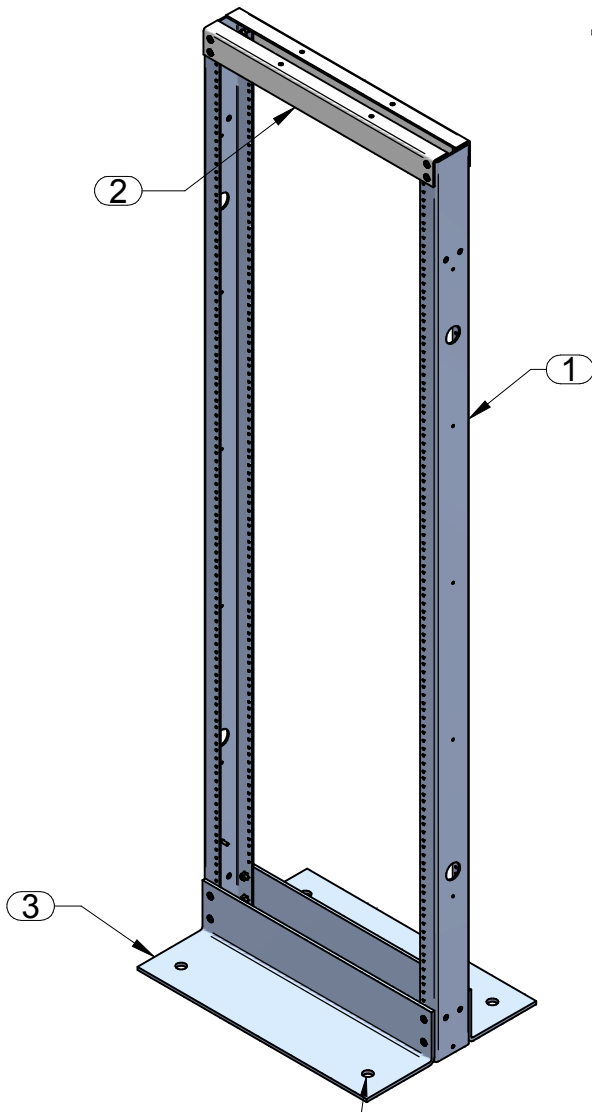

ASSEMBLY INSTRUCTIONS:

A) Fasten the base supports (Item 3) and top supports (Item 2) to the frame verticals (Item 1) using the 1/4" flat head hardware (Items 4 & 5) supplied. See assembly detail above.

B) Use a Phillips screw driver and a 7/16 wrench to tighten hardware. NOTE: Max torque on all hardware should not exceed 80 in-lbs.

C) Note: Holes are provide in rack frame base (4 places) for lagging into floor. Lag bolts are not included.

Note: holes are provided in rack frame base (4 places) for lagging into floor. Lag bolts are not included

PARTS LIST

ITEM No.	DESCRIPTION	QTY
1	FRAME VERTICALS	2
2	TOP HORIZONTAL SUPPORTS	2
3	BASE SUPPORTS	2
4	1/4-20 FLAT HEAD SCREWS	16
5	1/4-20 KEP NUT	16

Place label where shown both sides

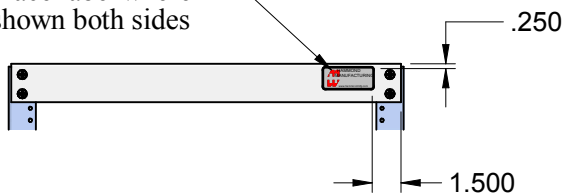

DETAIL A

TOOL BOX



7/16 Open Ended Wrench



Phillips Screw Driver

