

# 2WKL18 - SERIES

BUL87847  
REV. A

## ASSEMBLY INSTRUCTIONS

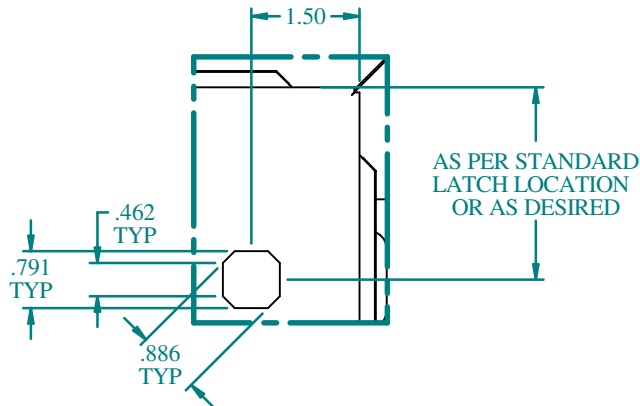

DETAIL Z  
STEP # 1

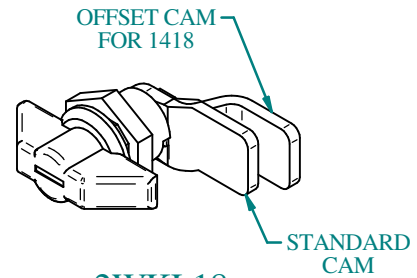

2WKL18  
STEP # 2

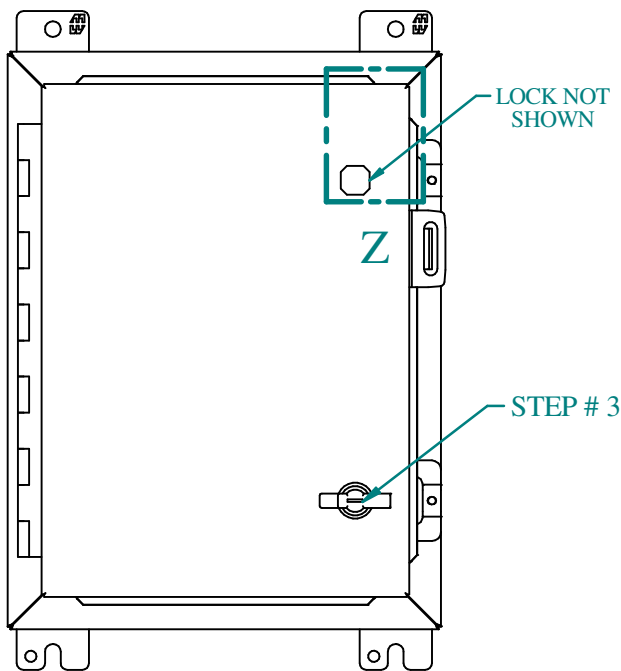

FRONT VIEW

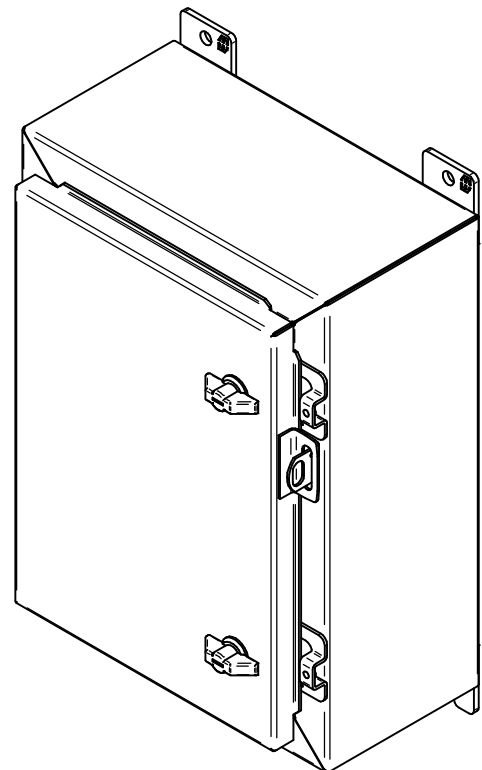

ISOMETRIC VIEW

## INSTRUCTIONS

1. Mark and machine cutouts as per Detail Z.
2. For 1418 Series, replace Standard cam with Offset cam.
3. Install lock as shown and torque nut to 190 in/lbs.

 **HAMMOND  
MANUFACTURING™**  
[www.hammondmfg.com](http://www.hammondmfg.com)