

NWM - SERIES

INSTRUCTIONS FOR NWM

BUL88564
REV. C
PAGE 1 OF 10

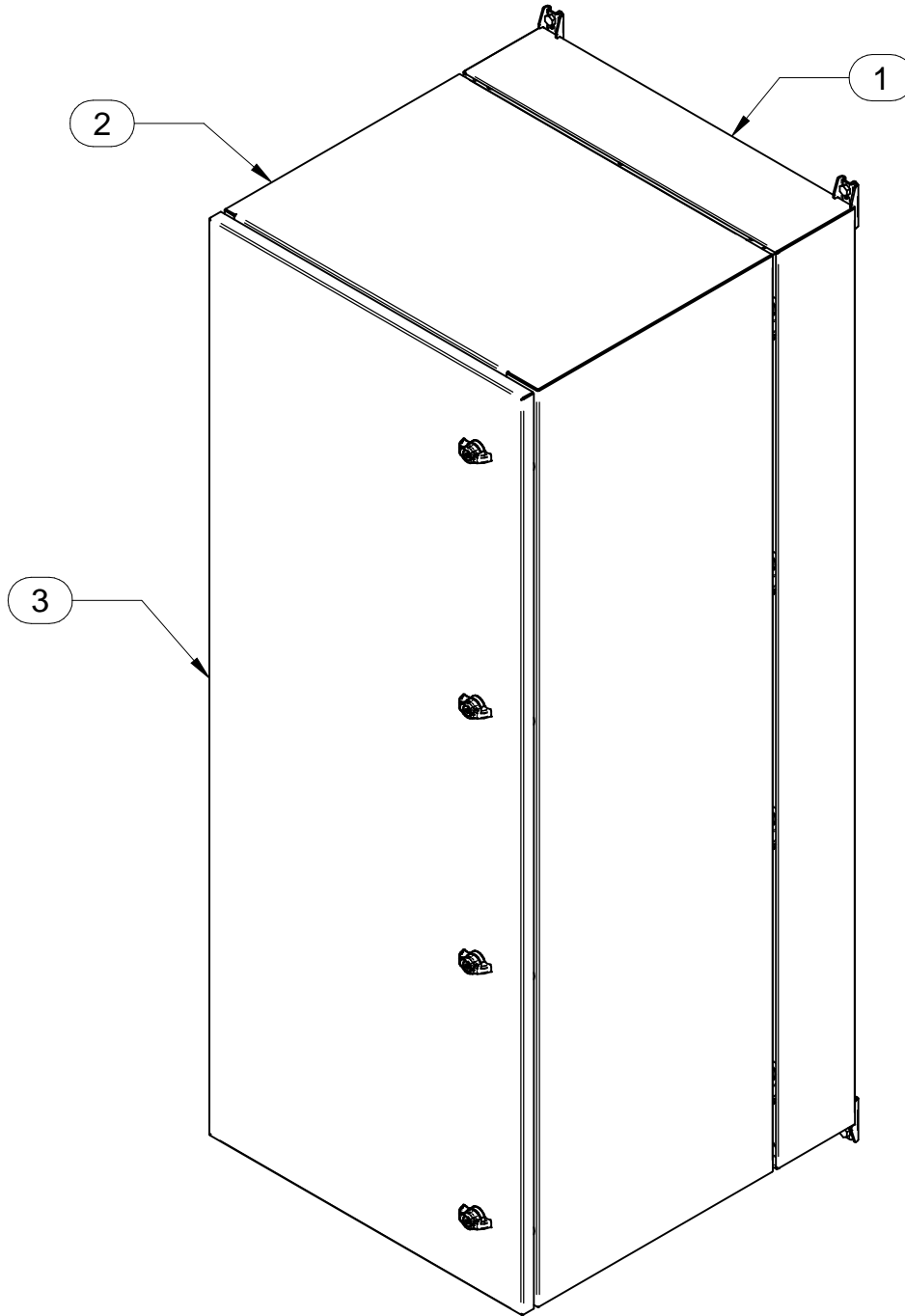

Item Number	Title	Quantity
1	NWM - REAR MOUNTING ASSY	1
2	NWM - CENTRE SECTION	1
3	NWM - DOOR	1



visit our website: www.hammondmfg.com
visitez notre site web:

IMPORTANT SAFETY CAUTIONS

NOTE: Read all instructions before installing and using the product.



Installation and assembly must be performed by qualified personnel.



Ensure that the floor/wall structure is able to withstand the weight of the cabinet while fully loaded.



Route all cords and cables away from moving parts and all possible pinch points.



Ensure unit is plumb and level for proper operation.



Always fully mount and secure enclosure or rack system before loading equipment.



Evenly distribute all mounted loads and equipment to ensure stability within the system.



To reduce risk of personal injury and product damage always ensure a sufficient amount of personnel are present when loading, unloading, and moving the enclosure or rack system.



The following parts are not effectively bonded to the Protective Earth Terminal (PET): Mounting rails, Mid Section, and Door. If any part needs to be bonded to the PET it shall be done in accordance with Article 250 of the National Electric Code.



Suitable for mounting on concrete or other noncombustible surface only.

LOADING RACK SYSTEM

NOTE: When loading equipment into the enclosure or rack system ensure weight is distributed so that heavier loads are placed towards the bottom of the rack to avoid unstable conditions.

Maximum Weight Capacity: 350 lb



HAMMOND
MANUFACTURING®

visit our website:
visitez notre site web:

www.hammondmfg.com

REVERSE SWING DIRECTION INSTRUCTIONS

1

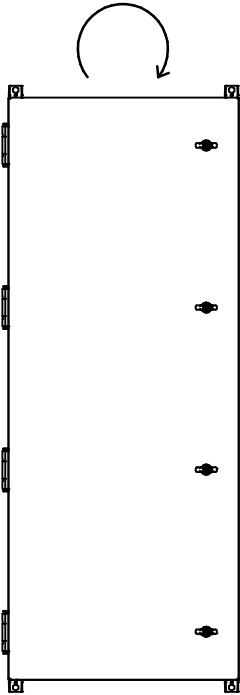

2

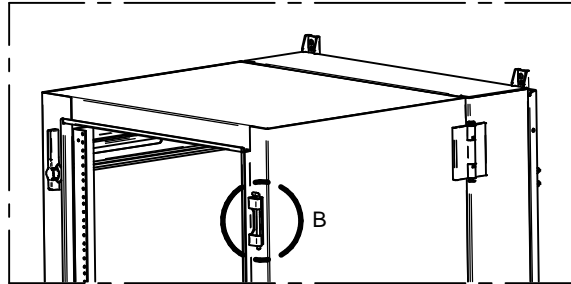

DETAIL A
WITHOUT DOOR

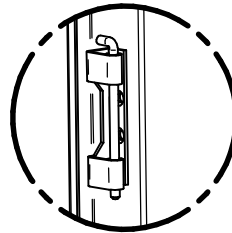

DETAIL B

A

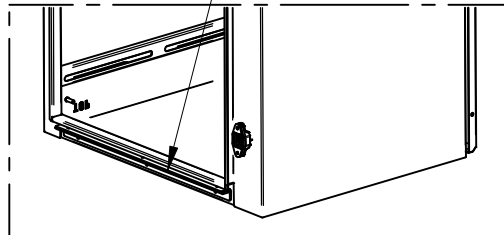
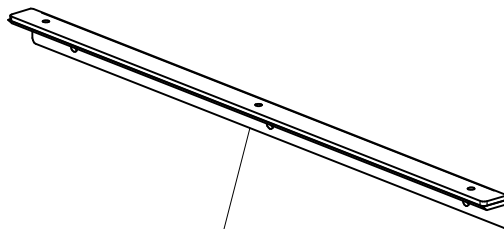
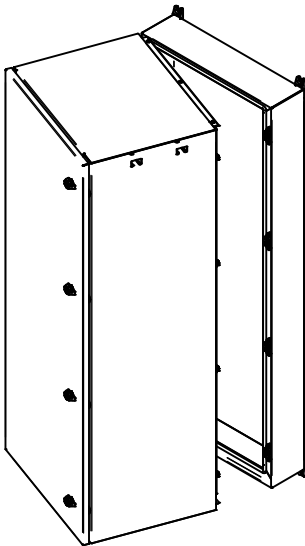
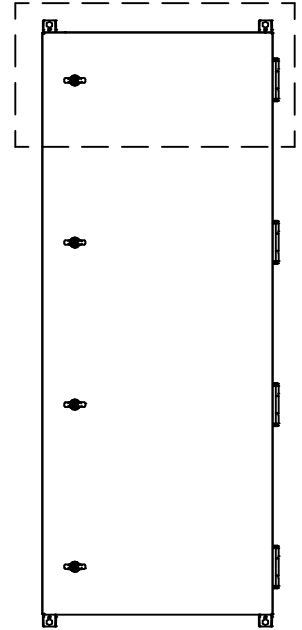

DETAIL C
WITHOUT REAR MOUNTING ASSY

C

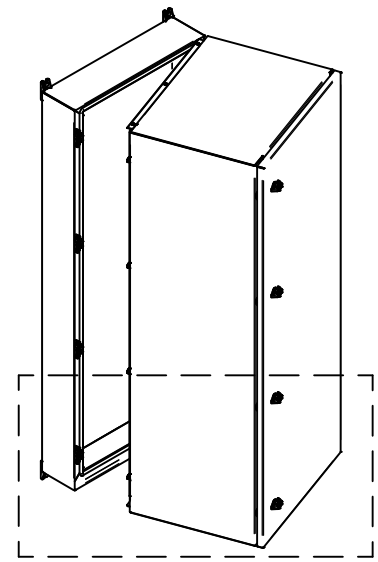

WALLMOUNT INSTRUCTIONS

OPTIONAL: Remove front section of wallmount to allow for an easier install.

1 SEPARATE HINGE PINS. DO NOT FULLY REMOVE HINGE PINS.

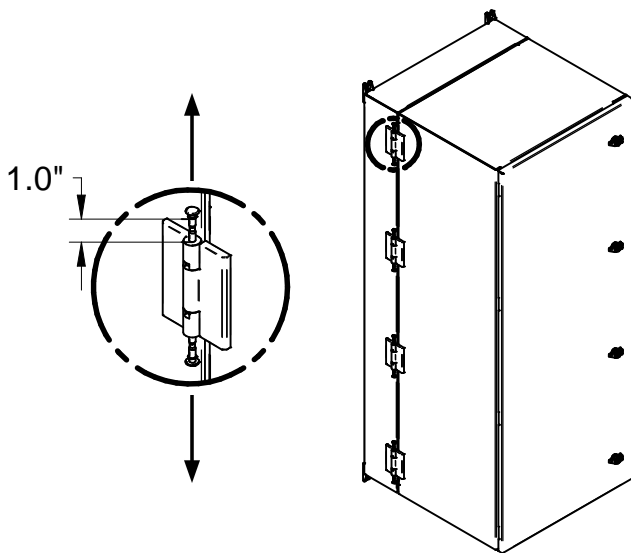

2

ENGLISH
WARNING!

CENTRE SECTION IS RELEASED.

CENTRE SECTION WILL DISENGAGE FROM REAR ASSEMBLY ONCE ROTATED 90 DEGREES

FRANÇAIS
AVERTISSEMENT!

LA SECTION CENTRALE EST LIBÉRÉE

LA SECTION CENTRALE SE DÉSENGAGE DE L'ASSEMBLAGE ARRIÈRE UNE FOIS QU'ELLE AURA PIVOTÉ DE 90 DEGRÉS

3 DISENGAGE WING KNOBS.

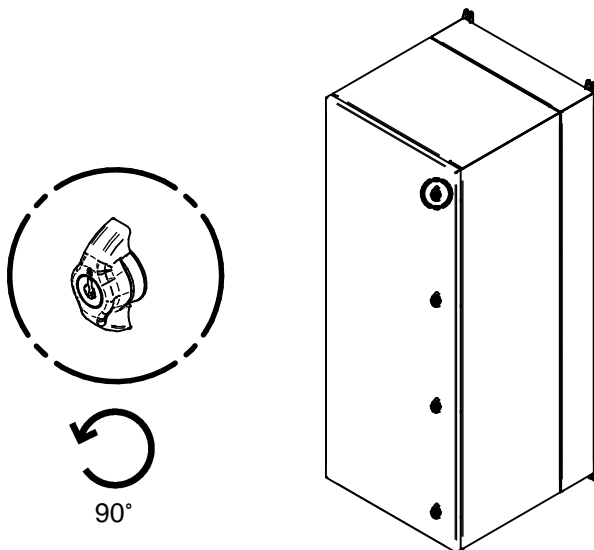

4

OPEN DOOR. DISENGAGE HANDLES.

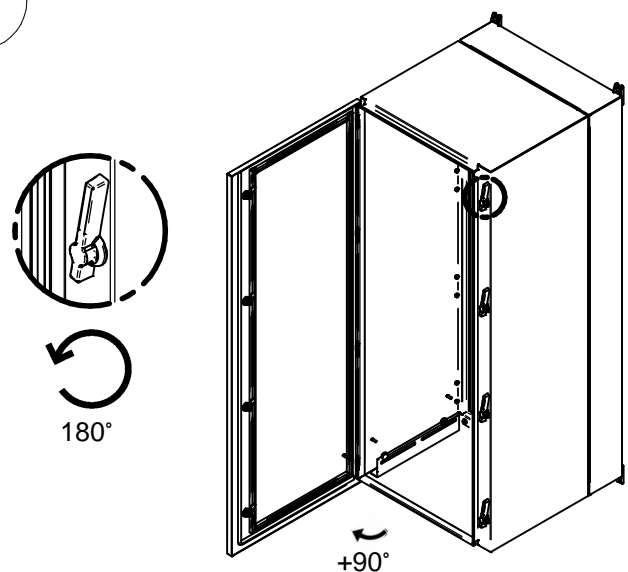

TOOL BOX



HAMMOND
MANUFACTURING®

visit our website:
visitez notre site web:

www.hammondmfg.com

5

OPEN CENTRE SECTION.

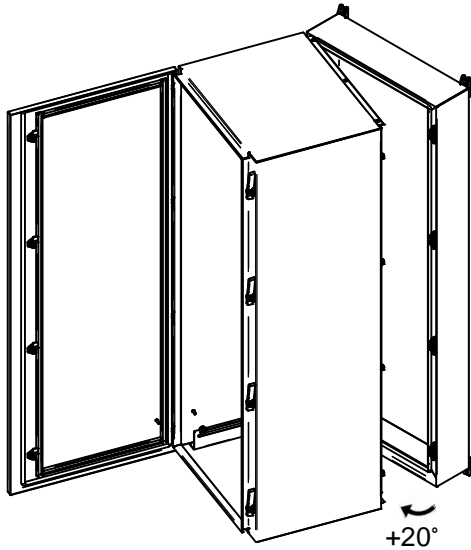

6

SHUT DOOR AND ENGAGE WING
KNOBS.

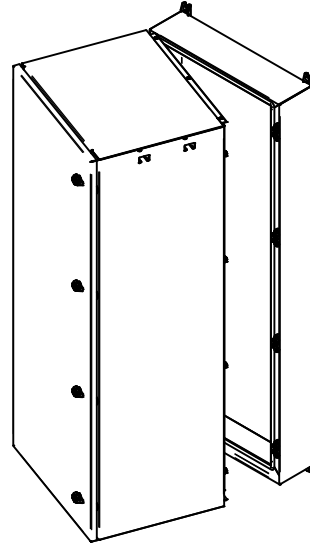

7

ENGLISH
WARNING!

CENTRE SECTION IS RELEASED.

ENSURE CENTRE SECTION IS SUPPORTED.

FRANÇAIS
AVERTISSEMENT!

LA SECTION CENTRALE EST LIBÉRÉE

S'ASSURER QUE LA SECTION CENTRALE EST
SOUTENUE

8

OPEN CENTRE SECTION 90 DEGREES.

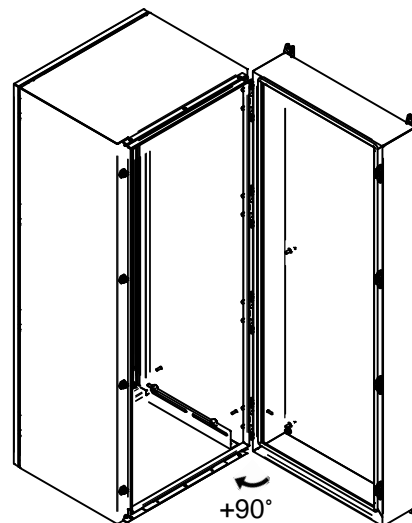

HAMMOND
MANUFACTURING®

visit our website:
visitez notre site web:

www.hammondmfg.com

9

REMOVE CENTRE SECTION.

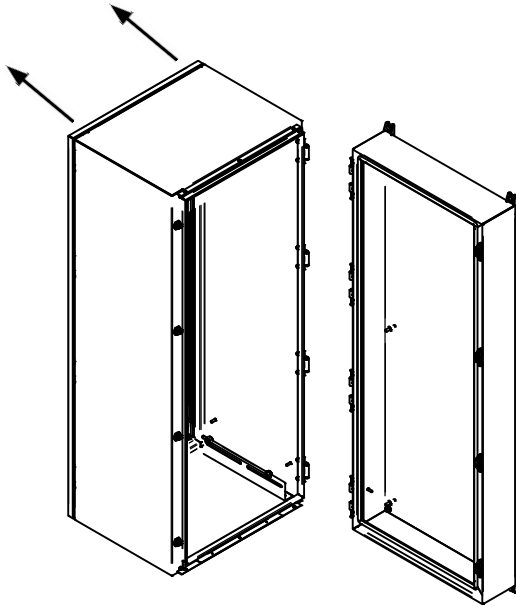

10

MARK MOUNTING HOLES.

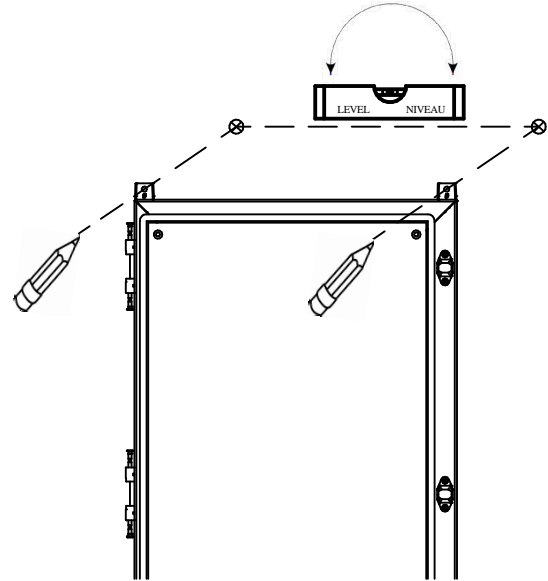

11

LAG CENTRE SECTION.

ENGLISH

Different wall materials require different types of screws.

Mount back pan using 3/8" dia lag bolts and standard flat washers.

FRANÇAIS

Les différents matériaux de paroi murale nécessitent différents types de vis.

Monter l'arrière du boîtier à l'aide de tire-fond de 3/8 po de diamètre et de rondelles plates standard.

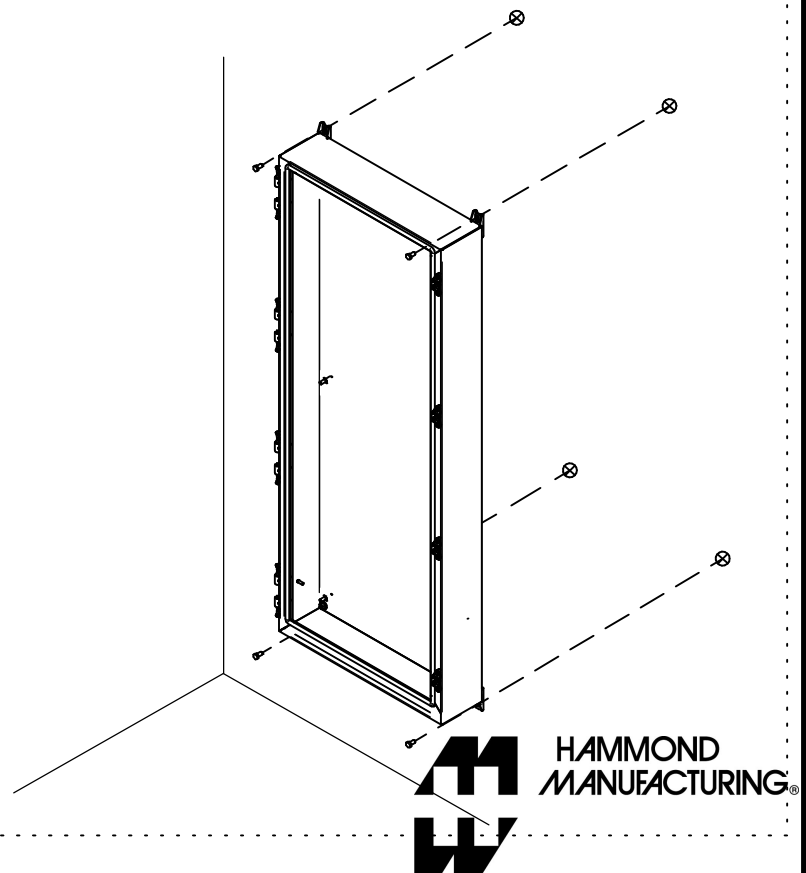

12 ALIGN HINGES. INSERT CENTRE SECTION.

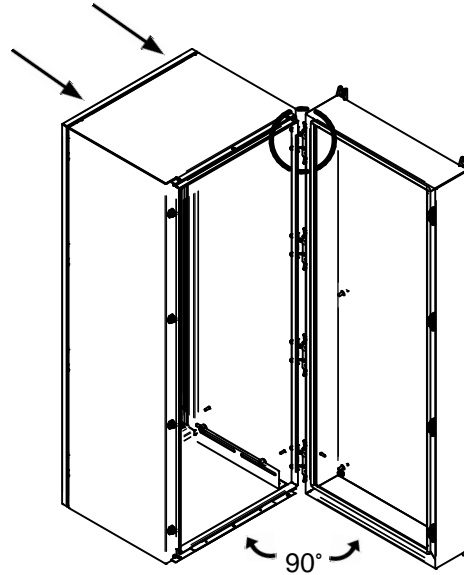
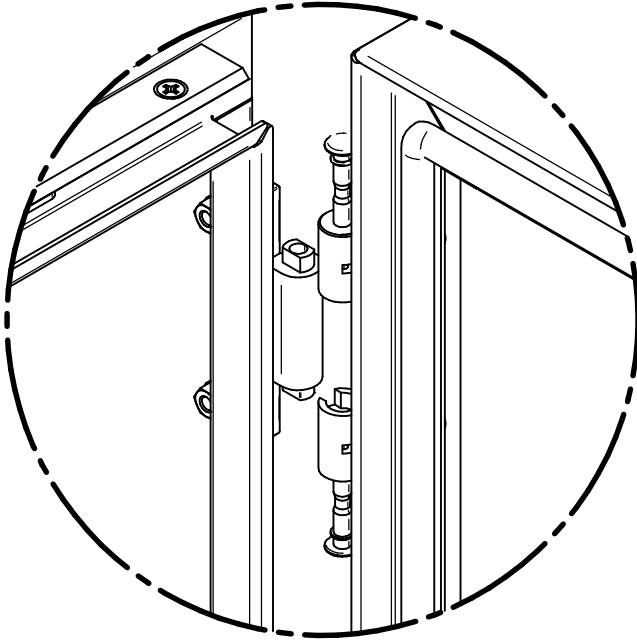

13 CLOSE CENTRE SECTION.

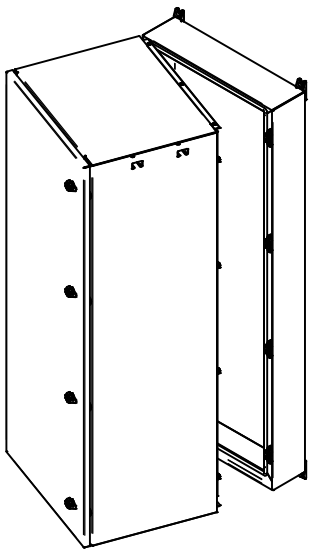

14 PUSH HINGE PINS TO CENTRE.

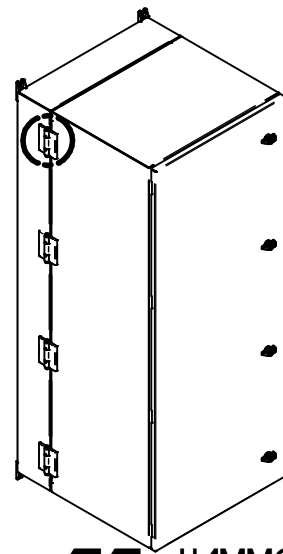
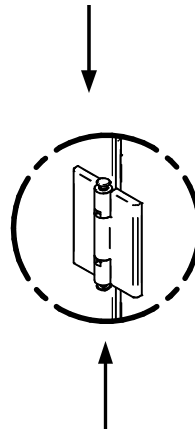

ALIGNMENT AND SQUARING INSTRUCTION

SHIMS MAY BE REQUIRED TO PROPERLY ALIGN SEALING SURFACES AND/OR SQUARE ENCLOSURES. MISALIGNMENT OF ENCLOSURE MAY COMPROMISE SEAL AND CAUSE EQUIPMENT FAILURES.

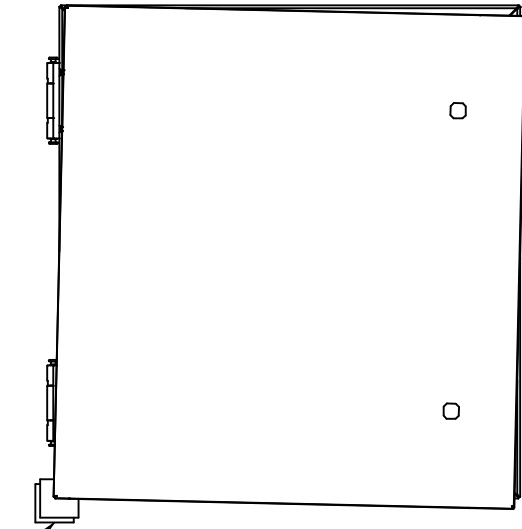

ADD SHIMS
TO CORNER

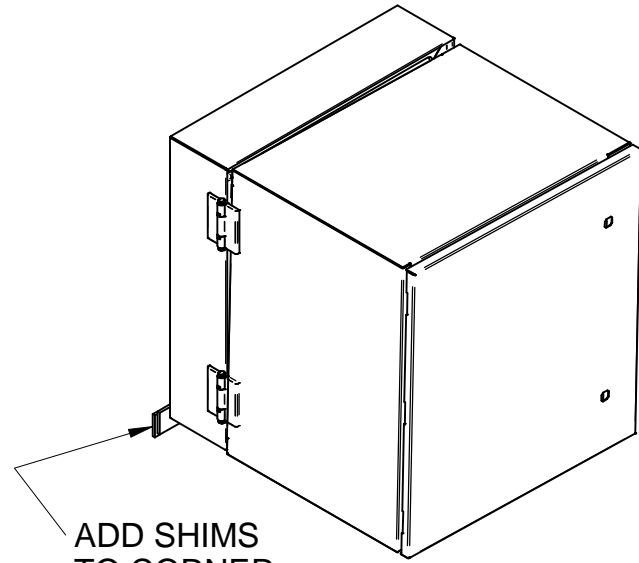

ADD SHIMS
TO CORNER

**LATCH SIDE LOWER
THAN HINGE SIDE**

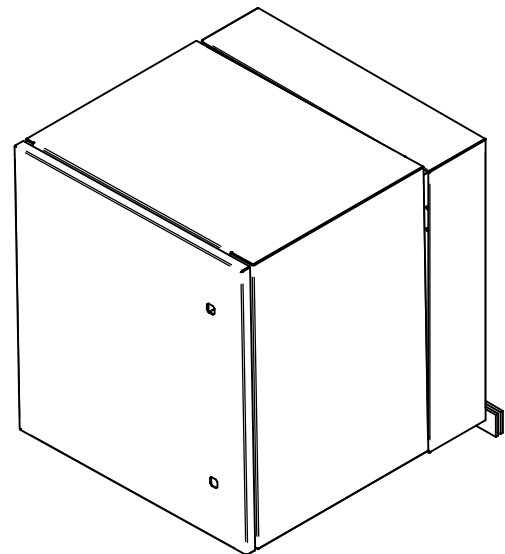
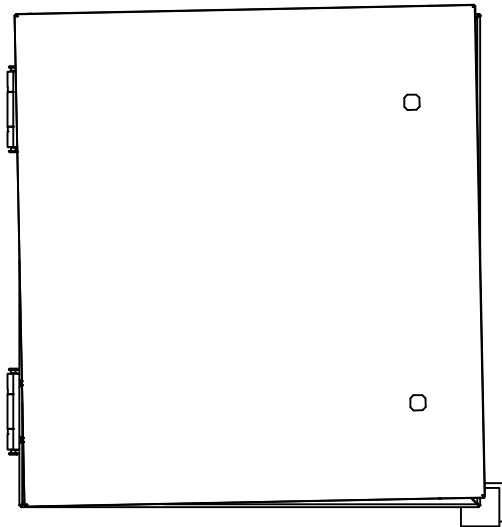

**LATCH SIDE HIGHER
THAN HINGE SIDE**



GROUNDING AND BONDING INSTRUCTIONS

1 Included within optional grounding kit (GRDKIT01):

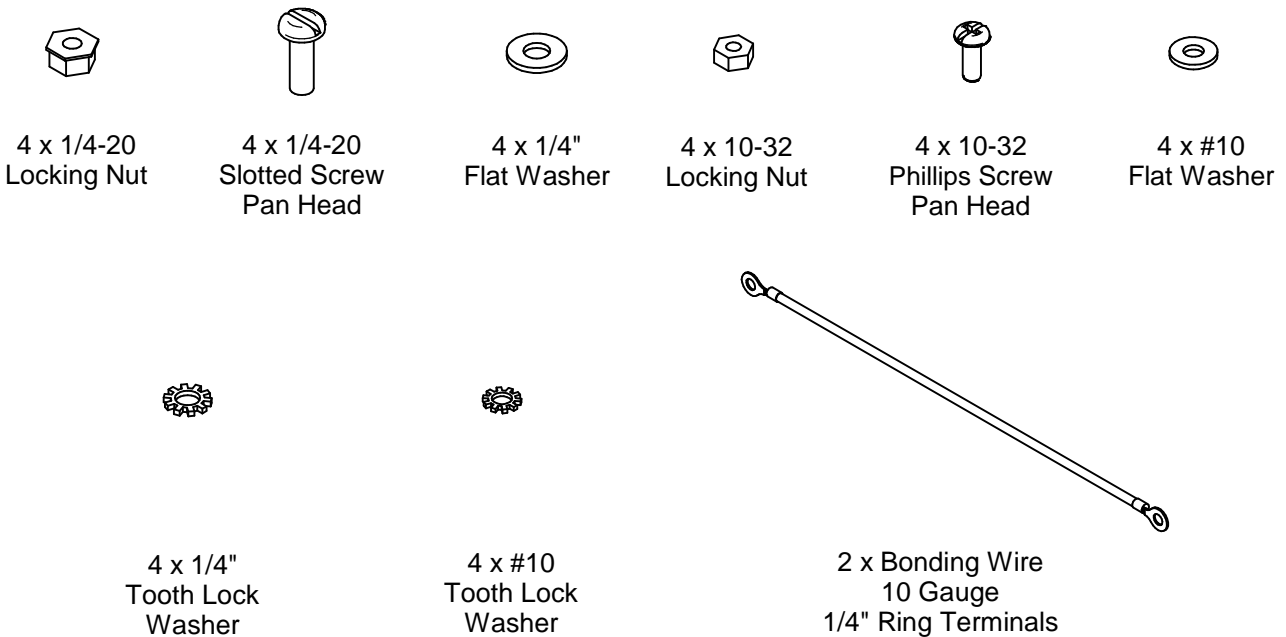

NOTE: PROTECTIVE EARTH TERMINALS (PET) ARE LABELLED WITH THE PROPER SYMBOL SHOWN IN FIGURE 1 AND ARE THE ONLY TERMINALS TO WHICH THE PROTECTIVE EARTH GROUND CONNECTION SHALL BE ATTACHED.

NOTE: ALL PROTECTIVE EARTH AND BONDING CONNECTIONS SHALL BE IN ACCORDANCE WITH ARTICLE 250 OF THE NATIONAL ELECTRIC CODE.



FIGURE 1



HAMMOND
MANUFACTURING®

visit our website:
visitez notre site web:

www.hammondmfg.com

2

Main Protective Grounding

When grounding the rack system or enclosure it is essential that the main protective ground is connected and secured first with its own nut before any bonding connections are made on top. (Figure 2)

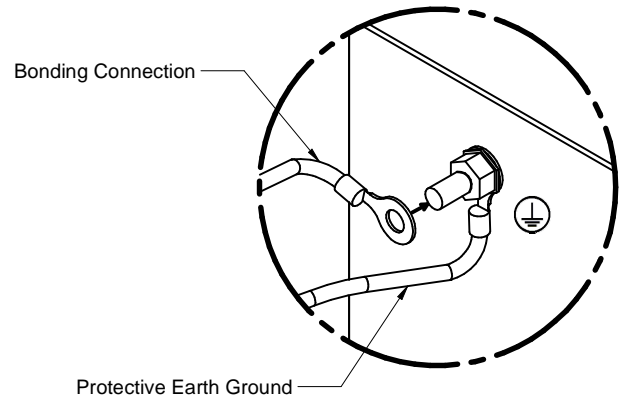

Figure 2

3

Bonding Connections

Centre Section: Attach bonding wire found in ground kit to a centre section bonding stud, closest to the hinged side of the enclosure, using the ring terminal and hardware provided. Attach opposite end of wire to the nearest PET on the rear section.

Door: Attach bonding wire to the door stud using the same method described above. Attach the opposite end to the nearest centre section bonding stud.

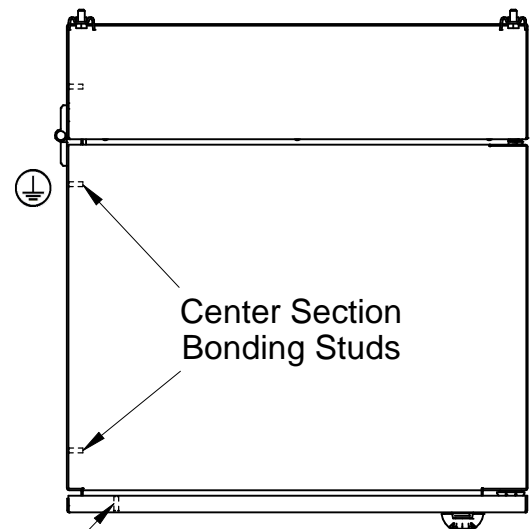

Top View

