

SECTION B-B

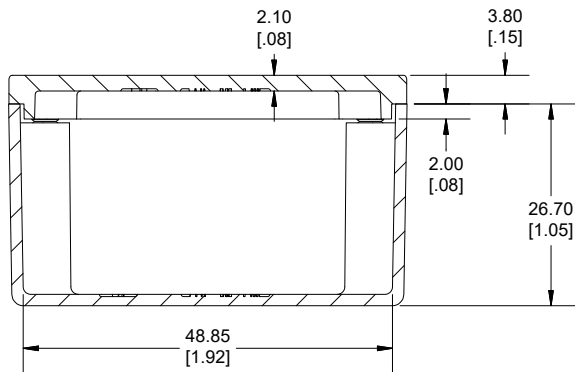

SECTION A-A

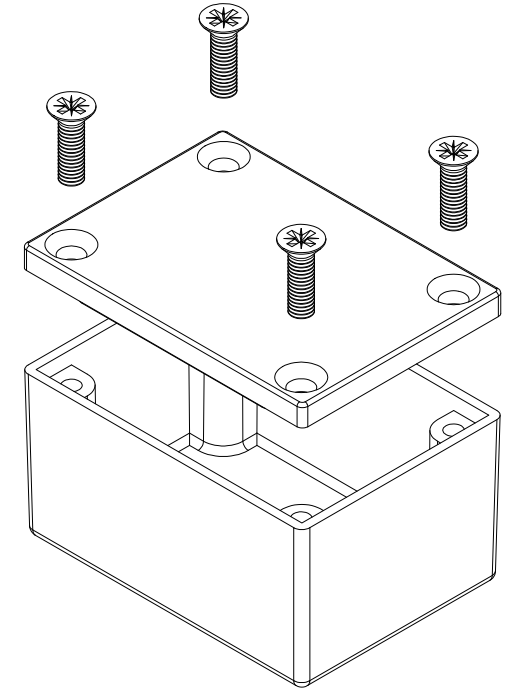

Enclosures can be Factory Modified (Milling, Drilling, Printing etc.)
 Contact Factory (modshop@hammfg.com) for quotes
 Solid models of this enclosure available in .stp or .x_t
 (Part number and text placement/orientation on our products are subject to change,
 we do not recommend using them as a locating reference for modification purposes)

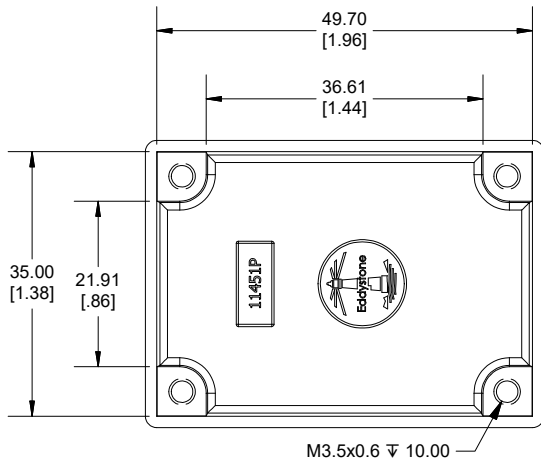

INSIDE BOX VIEW

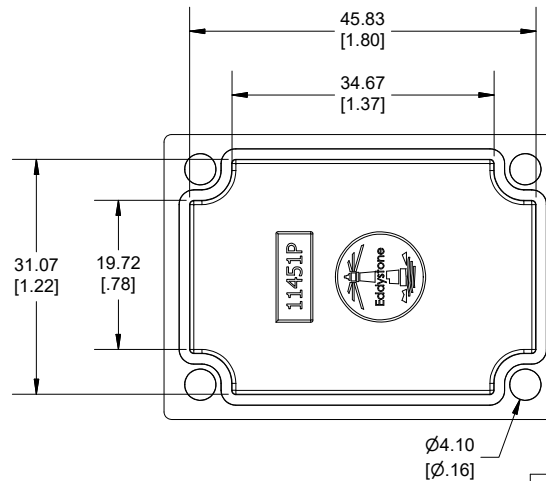

INSIDE LID VIEW

Dimensions:
 mm
 [inches]

NOTE

Purchased assembly includes Lid, Box and 4 cover screws.
 Box and lid are made from Diecast Aluminum Alloy.

Recommended Torque: 50-55 cN.m [71-78 ozf.in]

PART NUMBERS

Eddystone 11451

Natural Finish Enclosure	11451PSLA
--------------------------	-----------

ACCESSORIES

Cover Screws Pozidriv #2 (Pkg 100) [M3.5 x 12mm]	SCR0230-100
---	-------------

HAMMOND
 11451PSLA

www.hammondmfg.com