

EXTRUSION

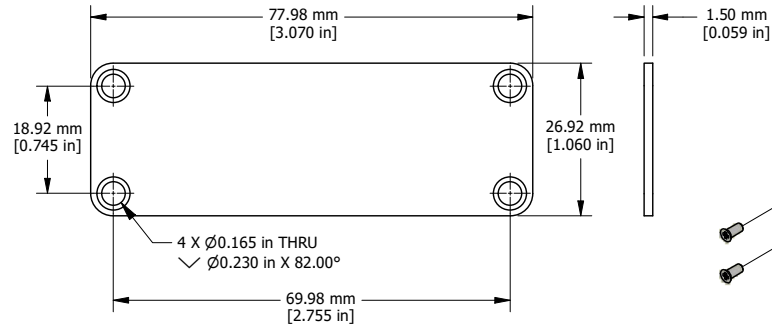

END PLATE

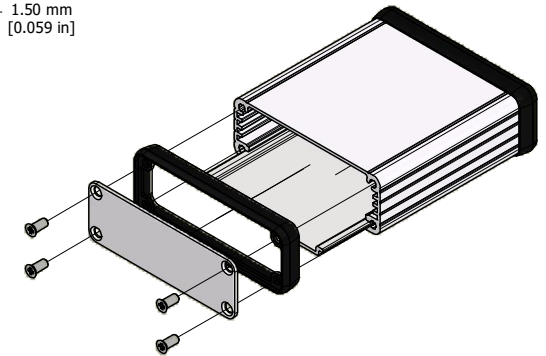

EXPLODED ISOMETRIC VIEW

EXTRUSION DESIGNED FOR 75MM WIDE PC BOARD

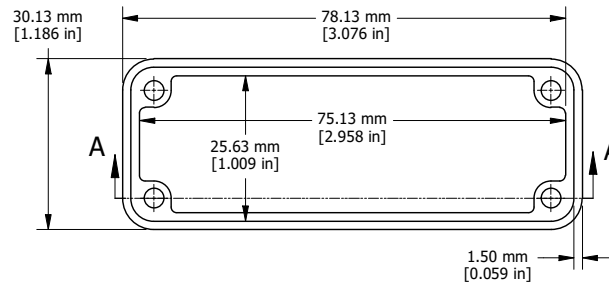
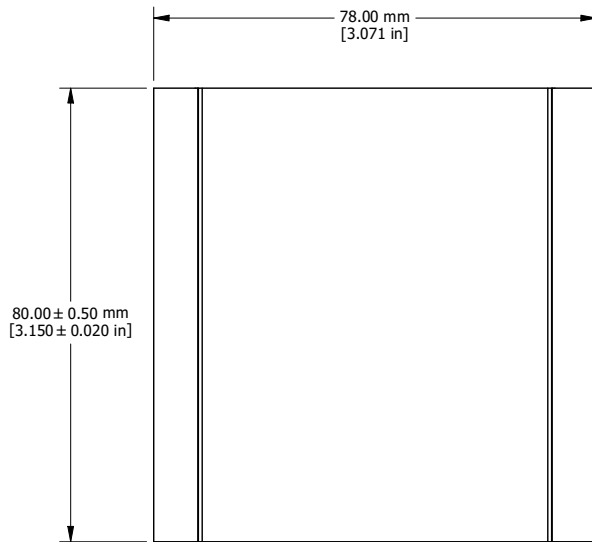

OPEN BEZEL

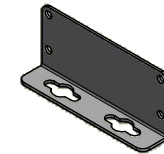
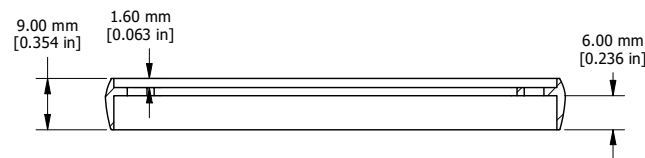

OPTIONAL FLANGE END PANELS  
1455JF

Enclosures can be Factory Modified ( Milling, Drilling, Printing etc. )  
Solid models of this enclosure available in STEP or IGES.  
Contact Factory [mjm@hammondmfg.com](mailto:mjm@hammondmfg.com)

NOTE	
Purchased assembly includes box, plastic bezels, end panels, #6 Taptight screws and self adhesive rubber feet.	
Box made from Extruded Aluminum 6063.	
Bezels made with polycarbonate	

1455J801	
PART NUMBERS	
Clear Anodized	1455J801
Black Anodized	1455J801BK
Blue Anodized	1455J801BU
Red Anodized	1455J801RD
ACCESSORIES	
See website for accessories.	

