

TOP VIEW

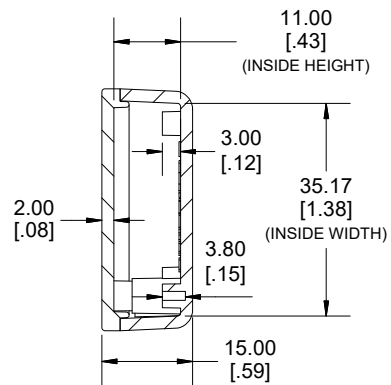

**END VIEW
SECTION B-B**

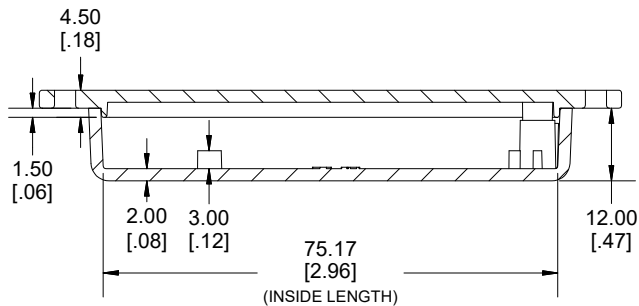
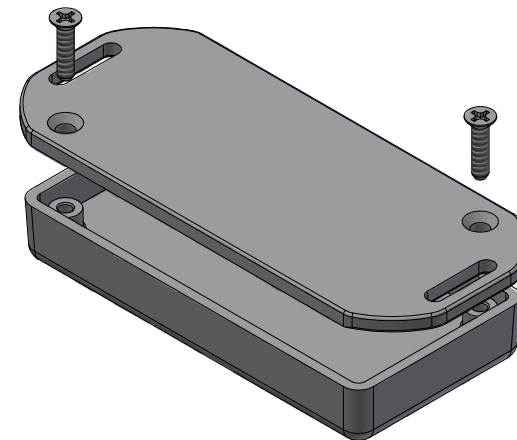

**SIDE VIEW
SECTION A-A**

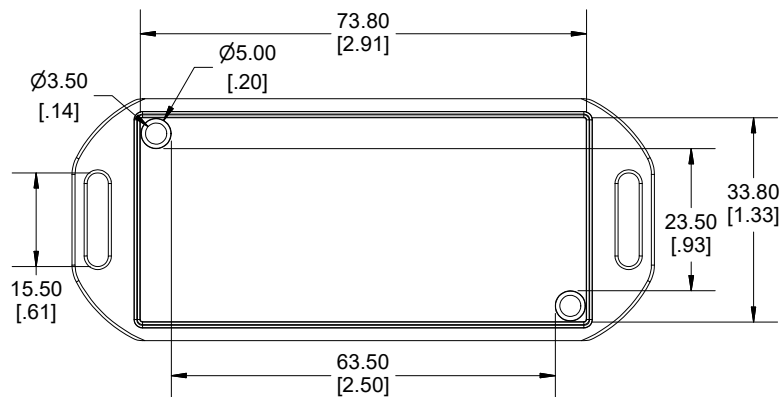

INSIDE LID

Enclosures can be Factory Modified (Milling, Drilling, Printing etc.)
Contact Factory (modshop@hammfg.com) for quotes
Solid models of this enclosure available in .stp or .x_t
(Part number and text placement/orientation on our products are subject to change,
we do not recommend using them as a locating reference for modification purposes)

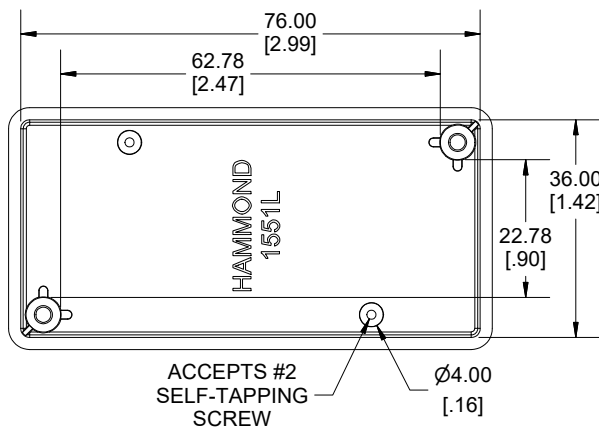

INSIDE BOX

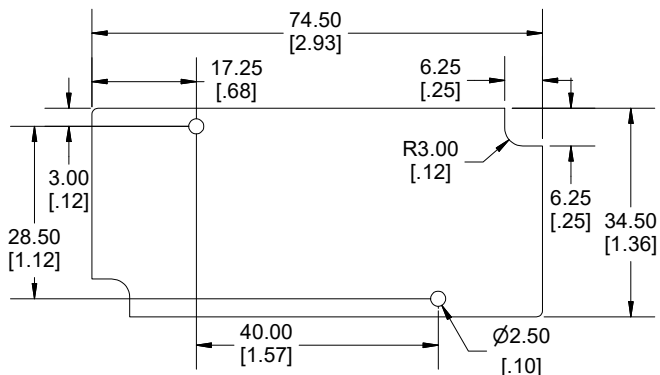

**MAXIMUM
P.C. BOARD SIZE**

Dimensions:
mm
[inches]

NOTE

Purchased assembly includes box, lid, 2 cover screws.
Enclosure molded from general purpose ABS Plastic.
Other materials / colours available consult factory.

Recommended Torque : (35-43) Ozf.in / (25-30) cN.m

PART NUMBERS

1551LFL Enclosure

Black Enclosure - Ral 9011 - UL94 - HB	1551LFLBK
Gray Enclosure - RAL 7035 - UL94 - HB	1551LFLGY
Tranlucent Blue - UL94 - HB	1551LFLTBU

ACCESSORIES

Black Cover Screws #4 X 1/2" Self-tapping	1591TS100BK (Pkg 100)
Plated Cover Screws #4 X 1/2" Self-tapping	1591TS100 (Pkg 100)
P.C. Board Screws [#2 x 3/16" self-tapping (4.8mm)]	1551ATS100 (Pkg 100)



HAMMOND®

1551LFL

www.hammondmfg.com