

TOP VIEW

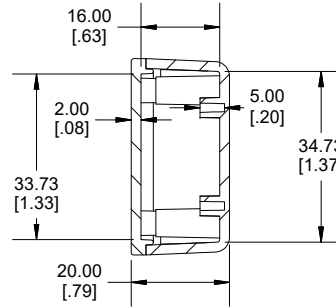

END VIEW SECTION A-A

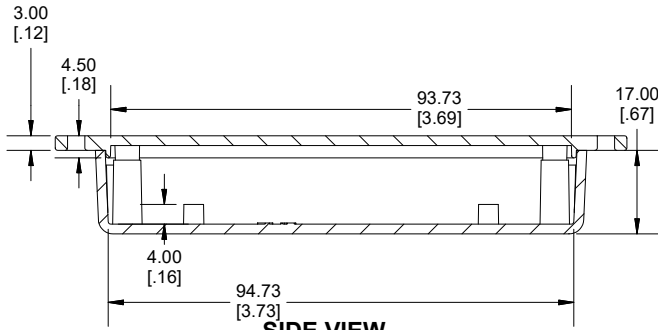
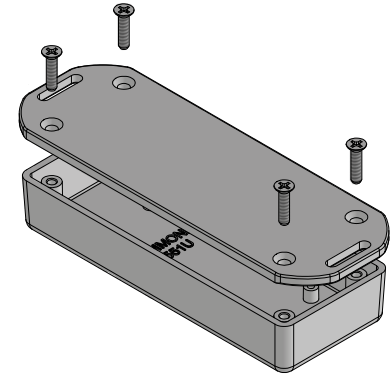

SIDE VIEW SECTION B-B

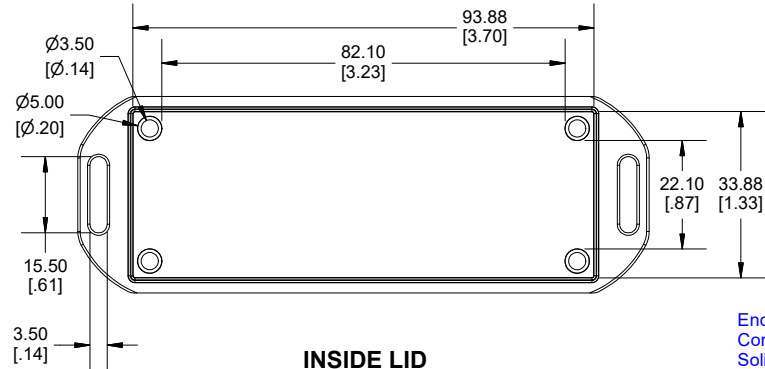

INSIDE LID

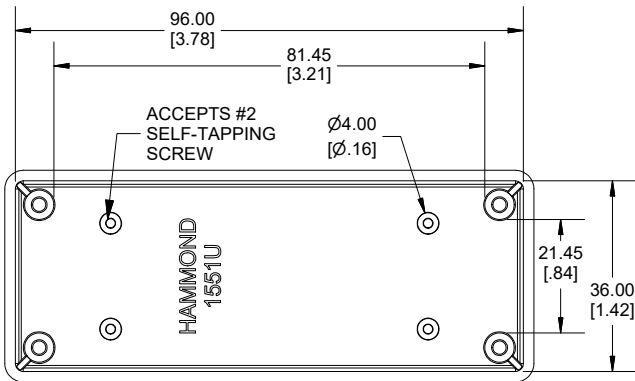

INSIDE BOX

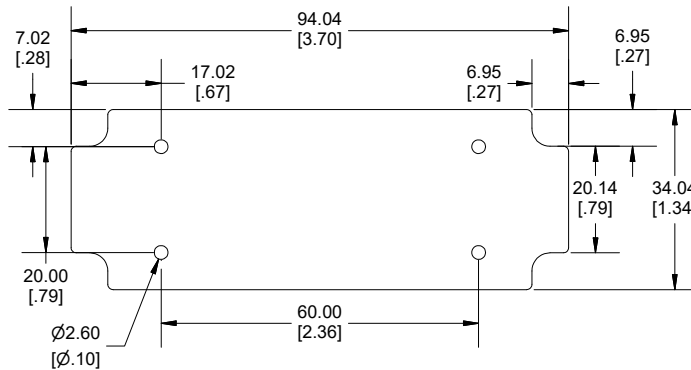

MAXIMUM P.C. BOARD SIZE

Dimensions:
mm
[inches]

Enclosures can be Factory Modified (Milling, Drilling, Printing etc.)
Contact Factory (modshop@hammfg.com) for quotes
Solid models of this enclosure available in .stp or .x_t
(Part number and text placement/orientation on our products are subject to change,
we do not recommend using them as a locating reference for modification purposes)

NOTE

Purchased assembly includes box, lid, 4 cover screws.
Enclosure molded from general purpose ABS Plastic.
Other materials / colours available consult factory.

Recommended Torque : (35-43) Ozf.in / (25-30) cN.m

PART NUMBERS

1551UFL Enclosure

Black Enclosure - Ral 9011 - UL94 - HB	1551UFLBK
Gray Enclosure - RAL 7035 - UL94 - HB	1551UFLGY
Translucent Blue - UL94 - HB	1551UFLTBU

ACCESSORIES

Black Cover Screws #4 X 1/2" Self-tapping	1591TS100BK (Pkg 100)
Plated Cover Screws #4 X 1/2" Self-tapping	1591TS100 (Pkg 100)
P.C. Board Plastite Self Tapping Screw [#2 x 3/16" self-tapping (4.8mm)]	1553WTS100 (Pkg 100)



HAMMOND

1551UFL

www.hammondmfg.com