

ASSEMBLY - VIEW FROM TOP

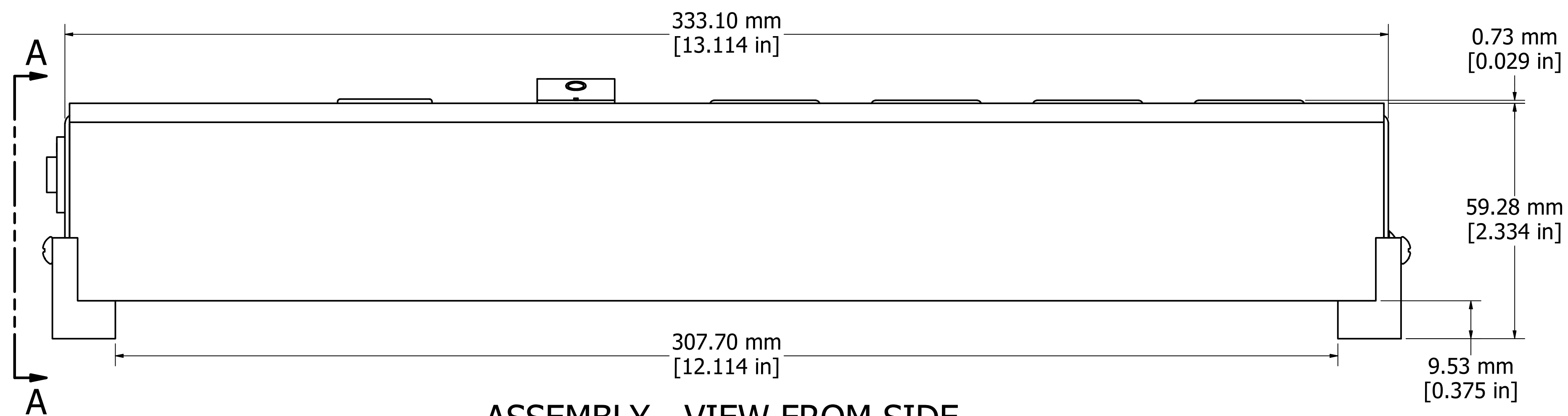

ASSEMBLY - VIEW FROM SIDE

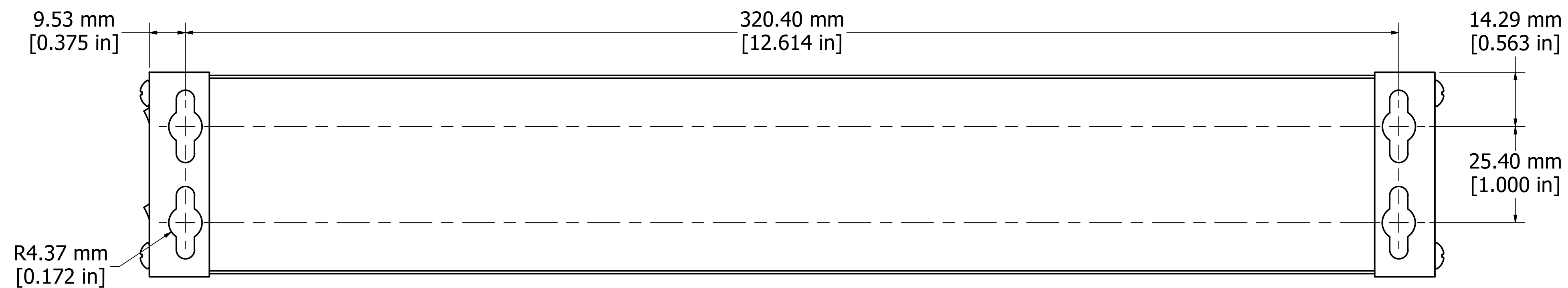

ASSEMBLY - VIEW FROM BOTTOM

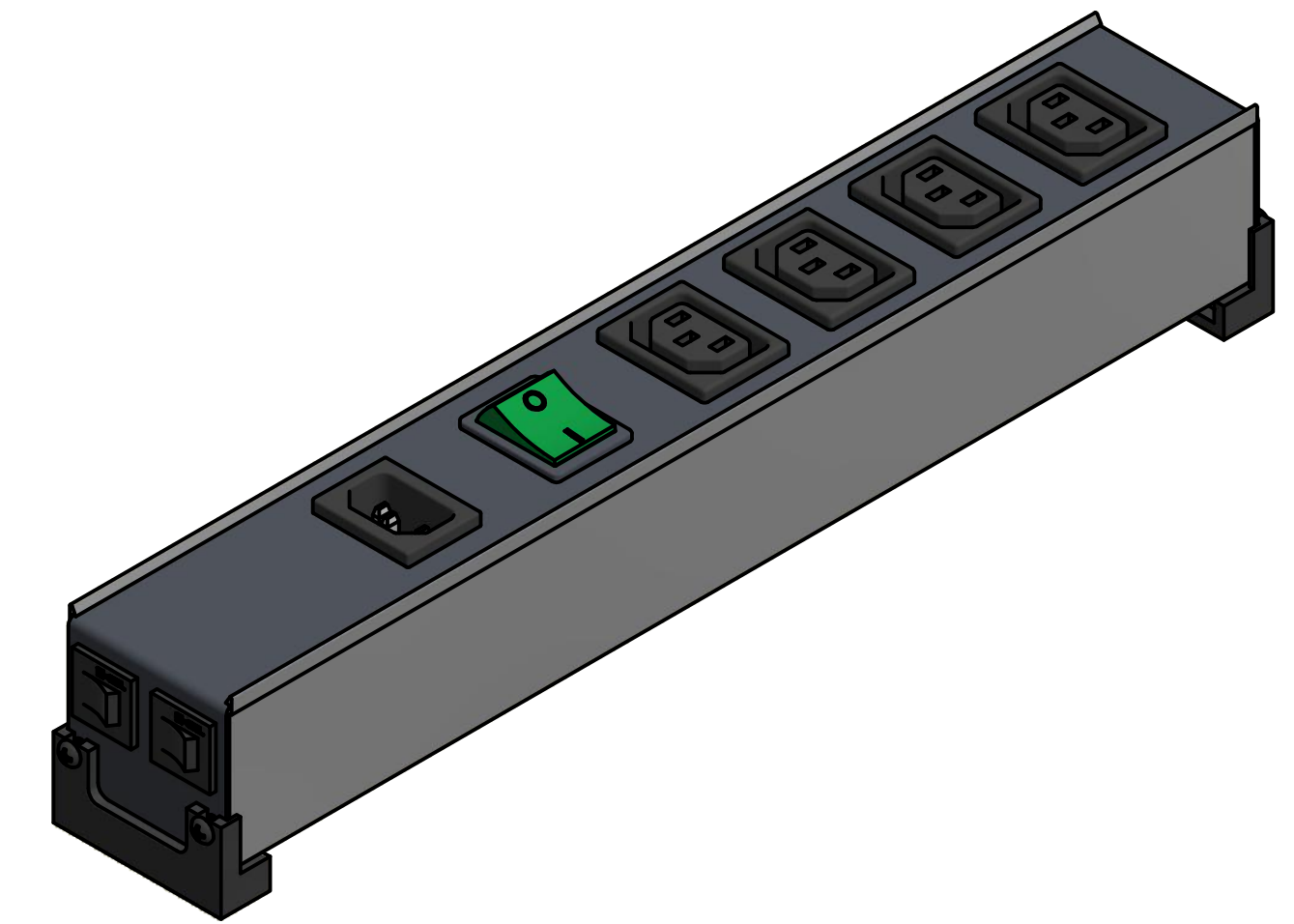

ISOMETRIC VIEW

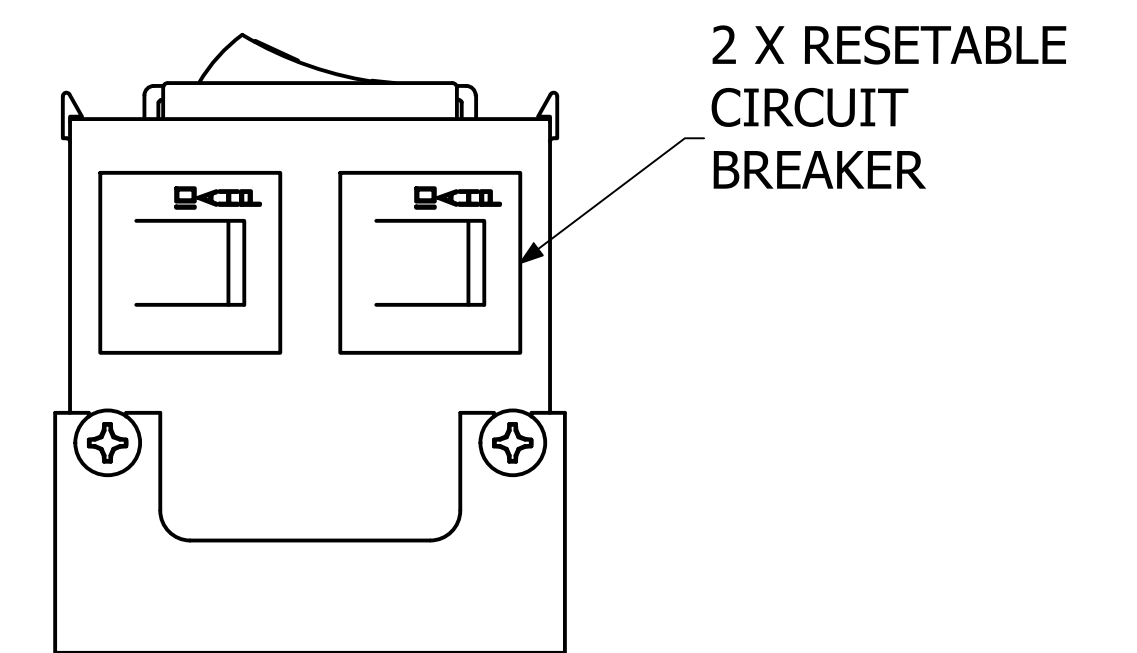

VIEW A-A

1581H4DP
Finish - Top - Black Painted Steel
Bottom - Aluminum Extrusion
Rated - 100-240 VAC, 50/60 Hz, 10 Amps
Approvals - cULus Listed UL 62368-1 (2nd Edition), 2014-12-01, and CAN/CSA C22.2 No. 62368-1-14 (2nd Edition).
- TUV-SUD Certified to EN 62368-1:2014/A11:2017, and IEC 62368-1:2014 (2nd Edition)
- CE compliant to European Low Voltage Directive 2014/35/EU



**HAMMOND
MANUFACTURING™**

1581H4DP

www.hammondmfg.com