

**TOP VIEW**

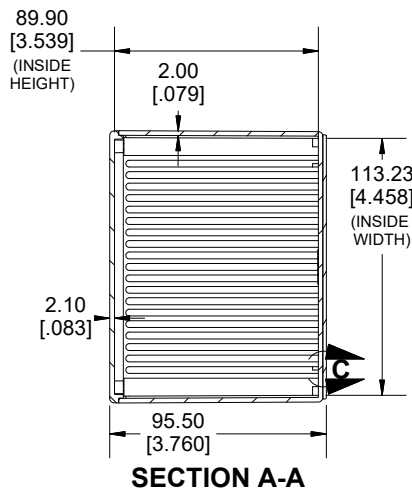

**SECTION A-A**

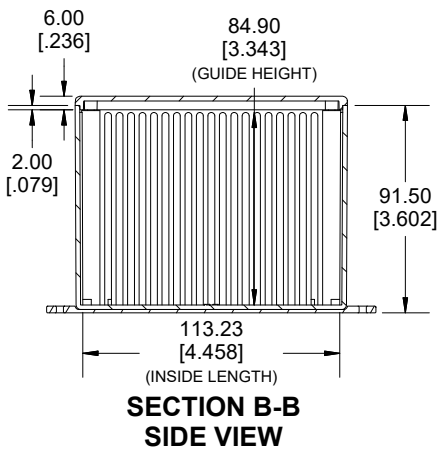
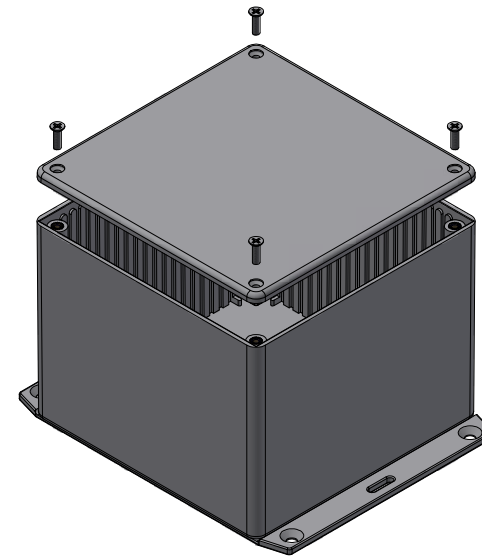

**SECTION B-B  
SIDE VIEW**

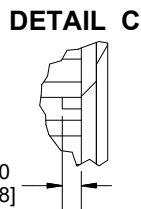

**DETAIL C**

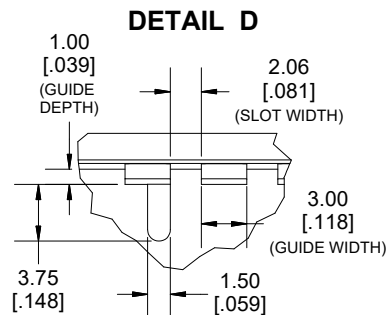

**DETAIL D**

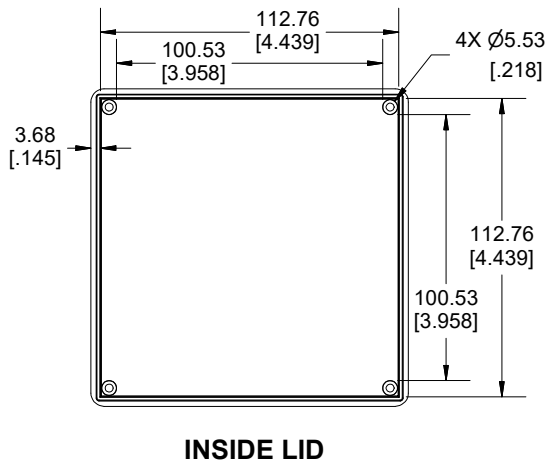

**INSIDE LID**

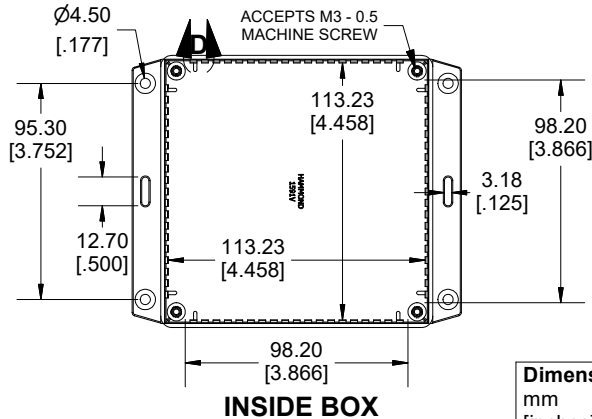

**INSIDE BOX**

**Dimensions:**  
mm  
[inches]

Enclosures can be Factory Modified (Milling, Drilling, Printing etc.)  
Contact Factory ([modshop@hammfg.com](mailto:modshop@hammfg.com)) for quotes  
Solid models of this enclosure available in .stp or .x\_t  
(Part number and text placement/orientation on our products are subject to change,  
we do not recommend using them as a locating reference for modification purposes)

**NOTE**

Purchased assembly includes box, lid, 4 cover screws, and pre-installed brass inserts.  
Enclosure made from FRABS

**Recommended Torque: 35.5-42.5 ozf.in (25-30 cN.m)**

**PART NUMBERS**

**1591V Enclosure**

Flame Retardant ABS Black	1591VF2BK
Flame Retardant ABS Grey	1591VF2GY

**Accessories**

Plated Cover screw M3 - 0.5 X 10mm (100Pkg)	1591MS100 (Silver)
	1591MS100BK (Black)
PC Board Card Adapters	1591Z6 (6Pkg)
	1591Z50 (50 Pkg)
	1591Z100 (100Pkg)
Nylon Belt / Pocket clip	1599CLIP (Black)
	1599CLIPGY (Grey)
Clear Lids - Flame Retardant Polycarbonate - Lid ONLY	1591VC

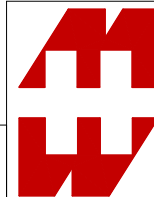

**HAMMOND  
MANUFACTURING.**  
**1591VF2**

[www.hammondmfg.com](http://www.hammondmfg.com)