

DIMENSIONS:	
A	0.200" ±0.030
B	0.250" ±0.030
C	1.000" ±0.063
L	1.625" ±0.063
W	1.438" ±0.063
H	1.125" ±0.063
G	0.025" SQ. ±0.005
J	0.125" ±0.005
M	1.063" ±0.063

MOUNTING SCREW #4
WEIGHT: 0.17LBS. APPROX.

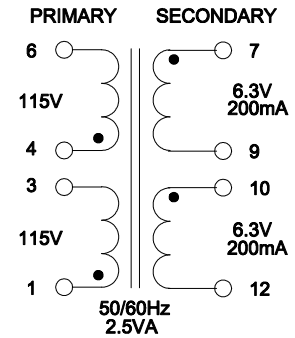
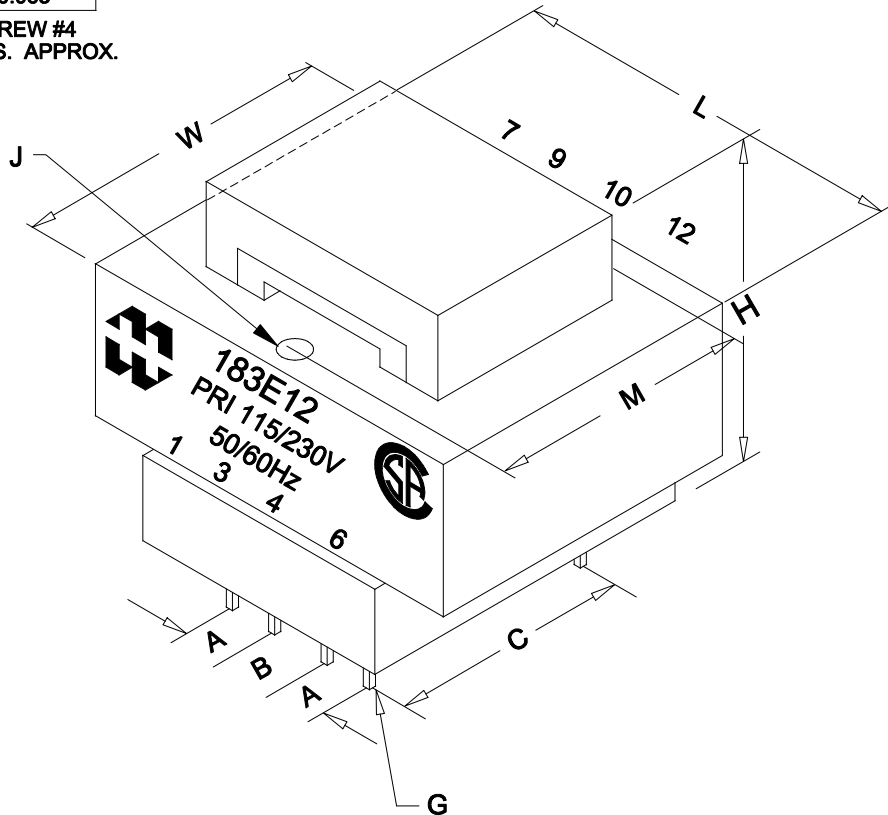

ELECTRICAL DATA:		
TESTS	CONDITIONS	ACCEPTANCE CRITERIA
lex	@ 115V, 60Hz, PIN 1 - PIN 3	21.6mA Max.
Sec. N.L.V	@ 115V, 60Hz, PIN 1 - PIN 3	
	PIN 4 - PIN 6 =	115.0V ±2%
	PIN 7 - PIN 9 =	8.799V ±2%
	PIN 10 - PIN 12 =	8.581V ±2%
DCR	@ 20°C, PIN 1 - PIN 3 =	687.8 Ω ±20%
	@ 20°C, PIN 4 - PIN 6 =	869.9 Ω ±20%
	@ 20°C, PIN 7 - PIN 9 =	5.232 Ω ±20%
	@ 20°C, PIN 10 - PIN 12 =	3.978 Ω ±20%
HIPOT	PRIMARY - SECONDARY	4000V, 60Hz, 1 SEC

REV.#	REVISION	DATE	HAMMOND ELECTRONIC DIVISION		PH # (519) 886-6181 FAX # (519) 886-9540
0	RELEASED.	C.I. 06/06/23	52 RANKIN PLACE, WATERLOO, ONTARIO, N2J 3Z5		
			DWG. BY: C. ILIE	CHK'D BY:	TITLE: CHASSIS MOUNT POWER TRANSFORMER
			DATE: 06/06/23	APP'D. BY:	
				DIMENSIONS: IN(X) MM()	DWG. NO. 183E12