

DIMENSIONS:	
A	3.750" ±0.063
B	4.200" ±0.125
C	3.125" ±0.063
D	3.125" ±0.063
E	2.750" ±0.063
F	3.313" ±0.063
G	0.203" X 0.375" ±0.015

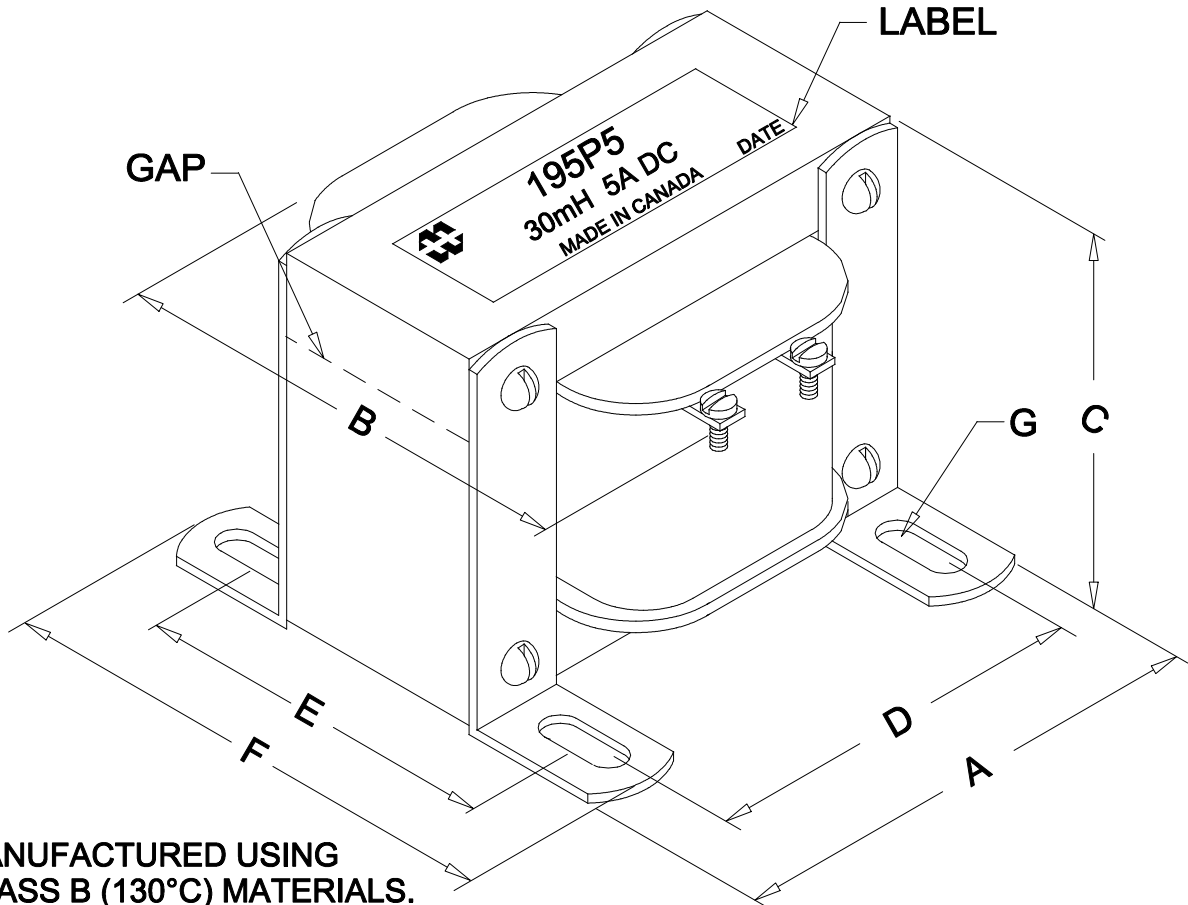
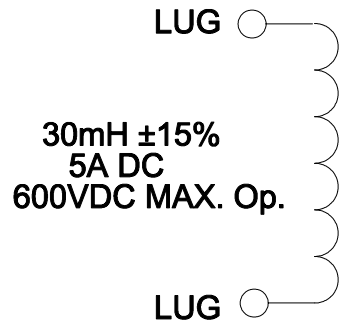

MANUFACTURED USING
CLASS B (130°C) MATERIALS.
RoHS COMPLIANT
OPERATING TEMP.:
-40°C TO 105°C
STORAGE TEMP.:
-40°C TO 85°C

ELECTRICAL DATA:

TESTS	CONDITIONS	ACCEPTANCE CRITERIA
INDUCTANCE	@ 5V, 60Hz, 5A DC, LUG - LUG	30mH ±15%
DCR	@ 20°C, LUG - LUG =	0.230 Ω ±15%
HIPOT	PRIMARY - CORE	2500V, 60Hz, 1 SEC

HAMMOND
MANUFACTURING™

ELECTRONIC DIVISION
52 RANKIN PLACE,
WATERLOO, ONTARIO, N2J 3Z5
PH # (519) 886-6181
FAX # (519) 886-9540

TITLE

CHOKE

NO	DATE	REVISION	DWG. BY
0	09/07/18	RELEASED.	C.I.
			C. ILIE
			DATE
			09/07/18
			DIM IN(X)MM()

195P5