

REV.#	REVISION	DATE	HAMMOND MANUFACTURING™		ELECTRONIC DIVISION	
0	RELEASED. DH	10/16/18	52 RANKIN PLACE, WATERLOO, ONTARIO, N2J 3Z5		PH # (519) 886-6181 FAX # (519) 886-9540	
			DWG. BY: D.HUTT	CHK'D BY:	TITLE: 1000VA POWER	DWG. NO.
			DATE: 05/27/16	APP'D. BY:	Wiring Diagram	240MG1000
				DIMENSIONS: IN(X) MM()		

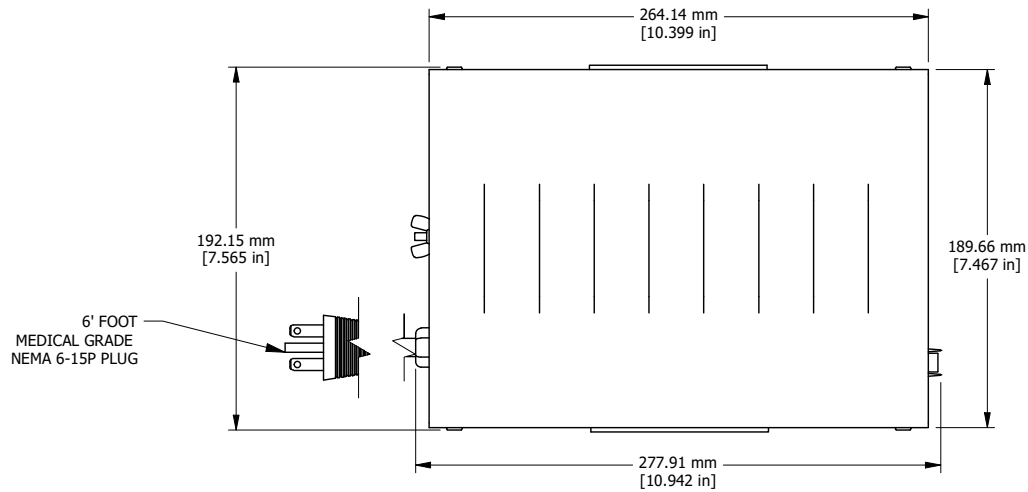

ASSEMBLY - VIEW FROM TOP



ASSEMBLY - ISOMETRIC VIEW

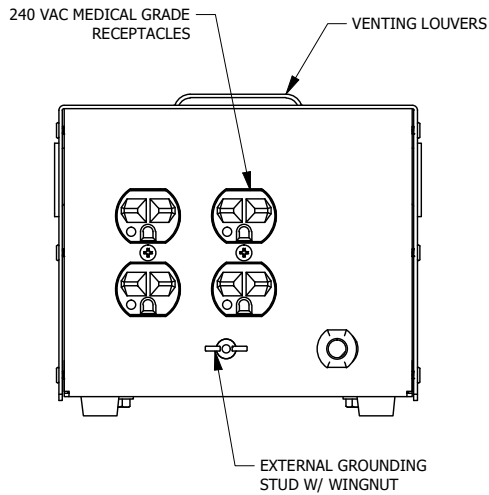

SECTION A-A

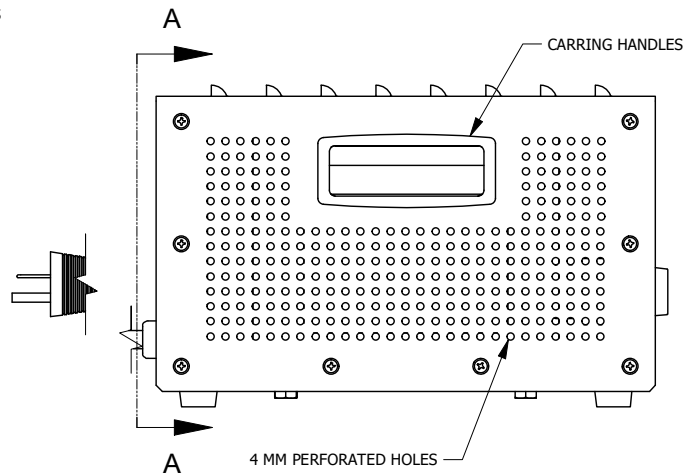

ASSEMBLY - VIEW FROM SIDE

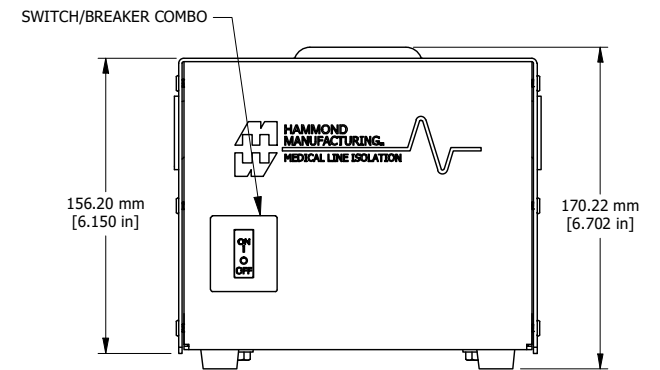

ASSEMBLY - VIEW FROM FRONT

240MG1000
Finish - White Powder Paint
Unit Rating - 1000 VA, 50/60 Hz
Rated Input - 240 VAC, 4.33 Amps
Rated Output - 240 VAC, 4.17 Amps
Approvals - cULus listed to UL60601-1 (1st Edition) & CAN/CSA-C22.2 No. 601.1-M90 (R2005)

