

SECTION B-B

SECTION A-A

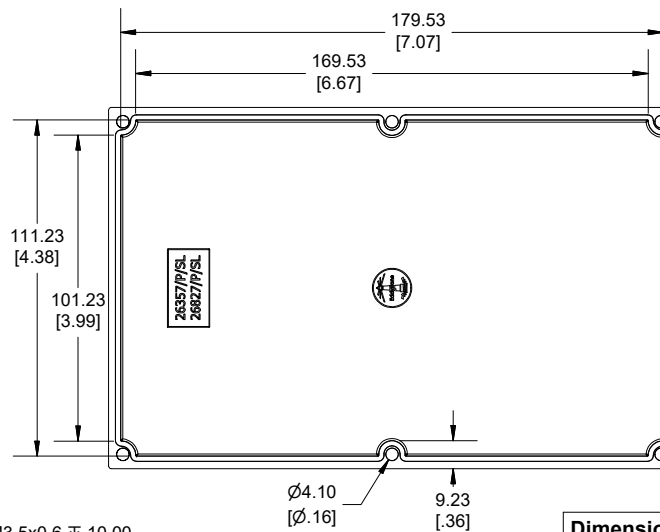
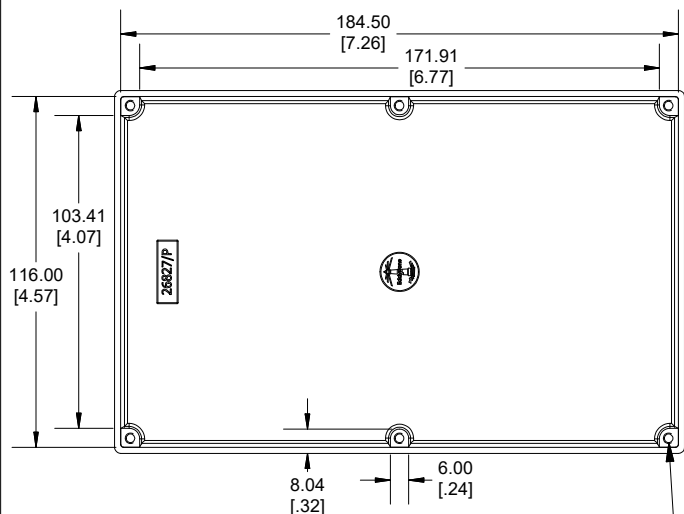

INSIDE BOX VIEW

INSIDE LID VIEW

Dimensions:  
mm  
[inches]

Enclosures can be Factory Modified (Milling, Drilling, Printing etc.)  
Contact Factory (modshop@hammfg.com) for quotes  
Solid models of this enclosure available in .stp or .x\_t  
(Part number and text placement/orientation on our products are subject to change,  
we do not recommend using them as a locating reference for modification purposes)

**NOTE**

Purchased assembly includes Lid, Box and 6 cover screws.  
Box and lid are made from Diecast Aluminum Alloy.

**Recommended Torque: 50-55 cN.m [71-78 ozf.in]**

**PART NUMBERS**

**Eddystone 26357**

Natural Finish Enclosure	26357PSLA
--------------------------	-----------

**ACCESSORIES**

Cover Screws Pozidriv #2 (Pkg 100) [M3.5 x 12mm]	SCR0230-100
---	-------------



**HAMMOND**  
**26357PSLA**

www.hammondmfg.com