

SECTION A-A

SECTION B-B

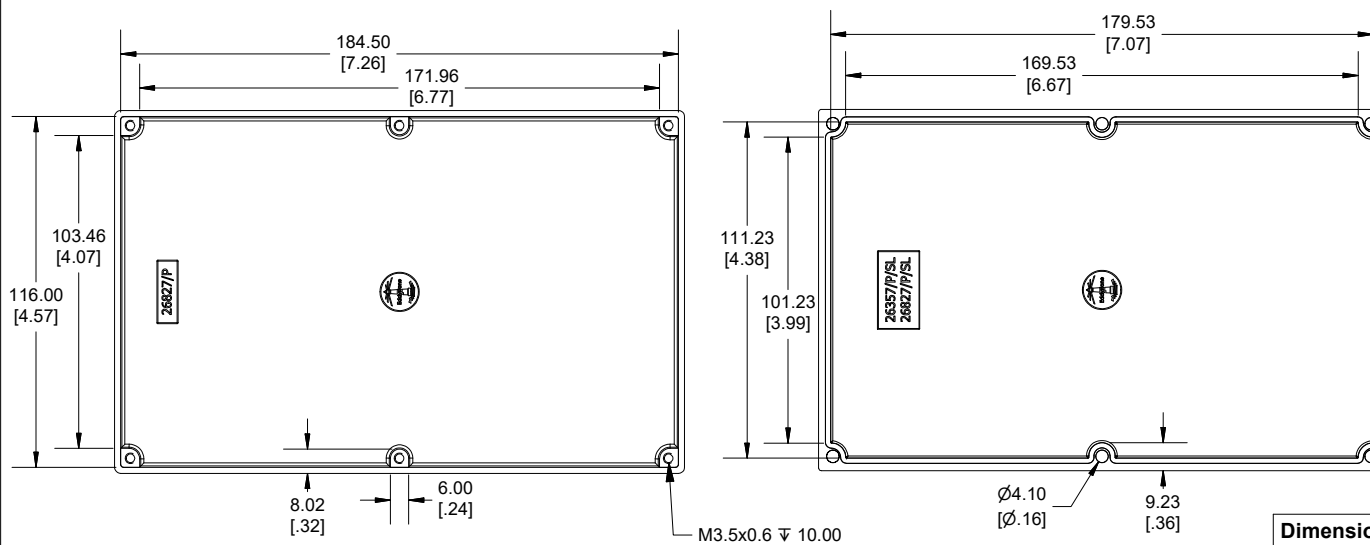

INSIDE BOX VIEW

INSIDE LID VIEW

Dimensions:
mm
[inches]

Enclosures can be Factory Modified (Milling, Drilling, Printing etc.)
Contact Factory (modshop@hammfg.com) for quotes
Solid models of this enclosure available in .stp or .x_t
(Part number and text placement/orientation on our products are subject to change,
we do not recommend using them as a locating reference for modification purposes)

NOTE

Purchased assembly includes Lid, Box and 6 cover screws.
Box and lid are made from Diecast Aluminum Alloy.

Recommended Torque: 50-55 cN.m [71-78 ozf.in]

PART NUMBERS

Eddystone 26827

Natural Finish Enclosure | 26827PSLA

ACCESSORIES

Cover Screws Pozidriv #2 (Pkg 100) | SCR0230-100
[M3.5 x 12mm]

HAMMOND
26827PSLA

www.hammondmfg.com