

REV.#	REVISION	DATE	HAMMOND MANUFACTURING™		ELECTRONIC DIVISION	
0	RELEASED. DH	10/15/18	52 RANKIN PLACE, WATERLOO, ONTARIO, N2J 3Z5		PH # (519) 886-6181 FAX # (519) 886-9540	
					DWG. BY: D.HUTT DATE: 05/27/16	CHK'D BY: APP'D. BY: DIMENSIONS: IN(X) MM()

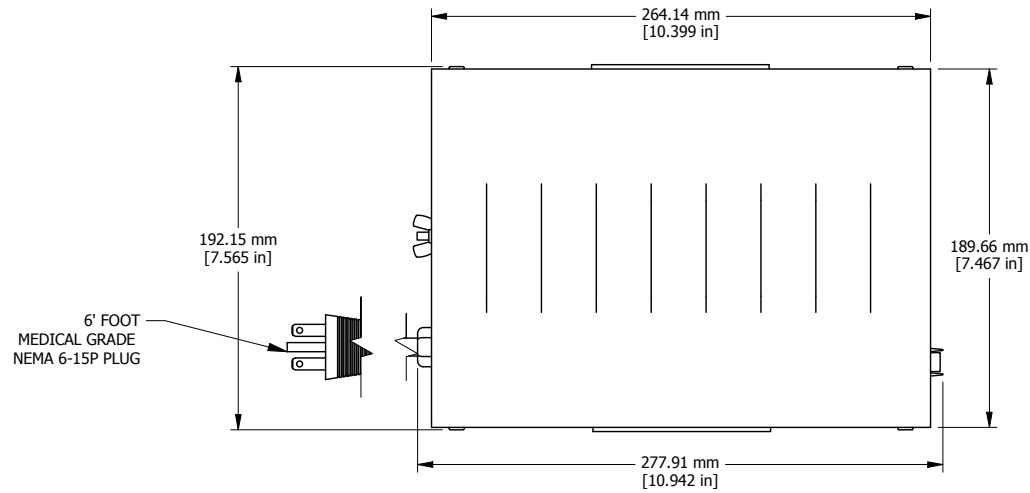

ASSEMBLY - VIEW FROM TOP



ASSEMBLY - ISOMETRIC VIEW

120 VAC MEDICAL GRADE RECEPTACLES

VENTING LOUVERS

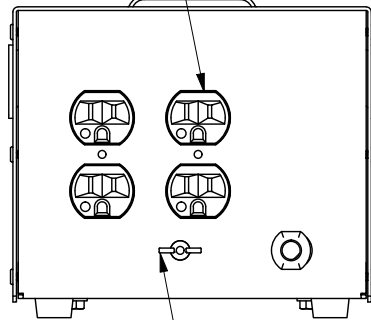

SECTION A-A

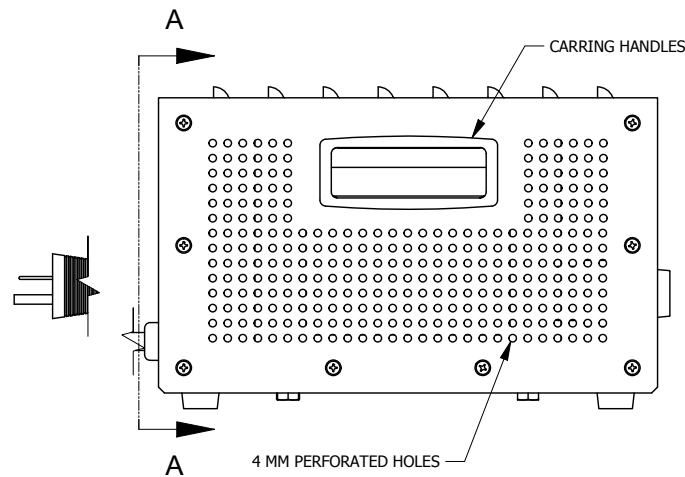

ASSEMBLY - VIEW FROM SIDE

SWITCH/BREAKER COMBO

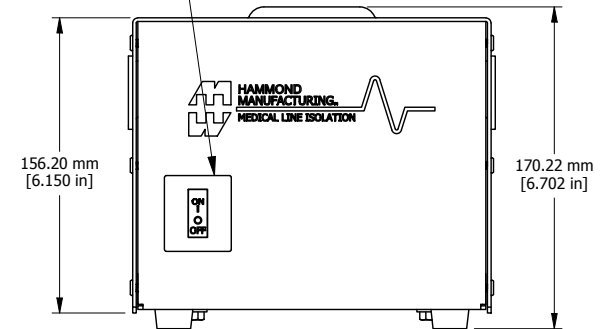

ASSEMBLY - VIEW FROM FRONT

289MG1000

Finish - White Powder Paint

Unit Rating - 1000 VA, 50/60 Hz

Rated Input - 240 VAC, 4.33 Amps

Rated Output - 120 VAC, 8.33 Amps

Approvals - cULus listed to UL60601-1 (1st Edition)

& CAN/CSA-C22.2 No. 601.1-M90 (R2005)

