

(2X)

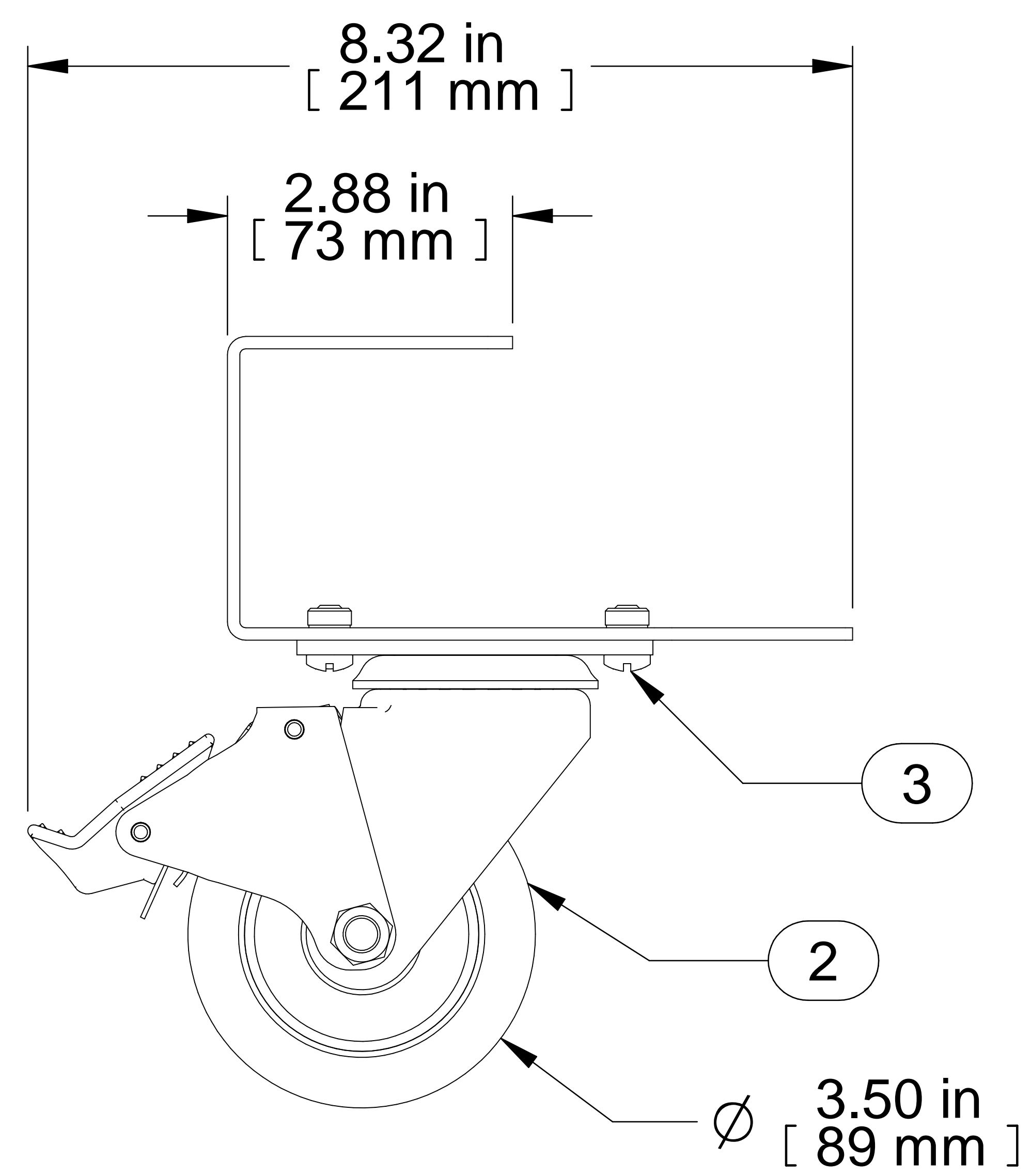
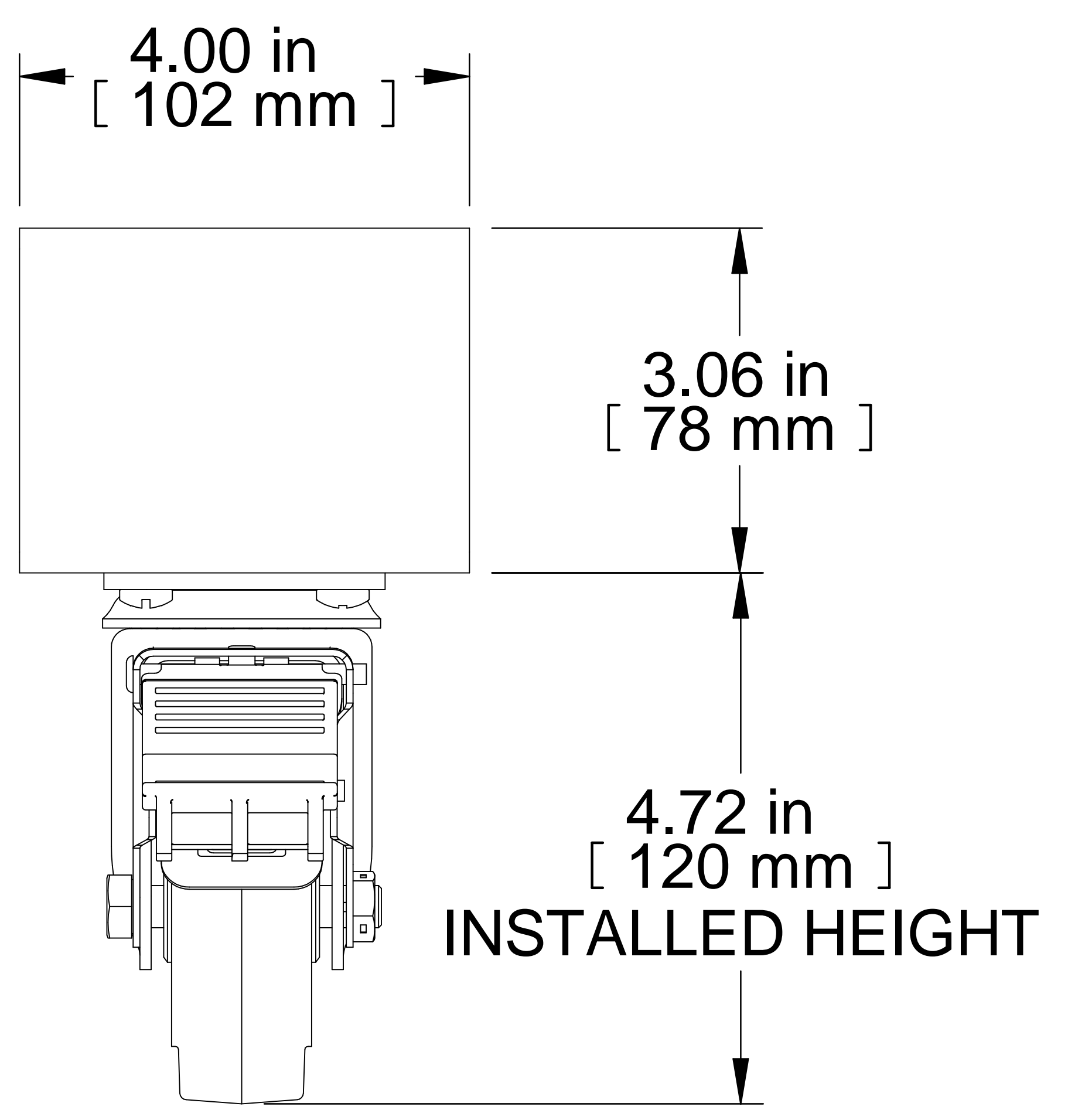

Item Number	Title	Quantity
1	C2 CASTER BRACKET	1
2	SWIVEL CASTER LOCKING 3.5" WHEEL	1
3	SCREW 1/4-20 X 5/8 RND HD ZP	4

PART NUMBERS
CCSTL PAINTED BLACK TEXTURED

NOTES
250 LB. weight capacity per caster.
Locking capability.
Sold in pairs.
Mounting Hardware Included
See Hammond Website for More Information

Français
Pour tous les détails sur nos produits,
svp veuillez consulter notre site www.hammondmfg.com
Data subject to change without notice. Isometric drawing not to scale.
Les données sont sujettes à changement sans préavis.

HAMMOND MANUFACTURING®
www.hammondmfg.com

PART NO. **CCSTL**