

| REV | ECN | DESCRIPTION | DATE        | ENG'R | CHK'D |
|-----|-----|-------------|-------------|-------|-------|
| A   | N/A | RELEASED    | May 14/2013 | NB    |       |
|     |     |             |             |       |       |
|     |     |             |             |       |       |

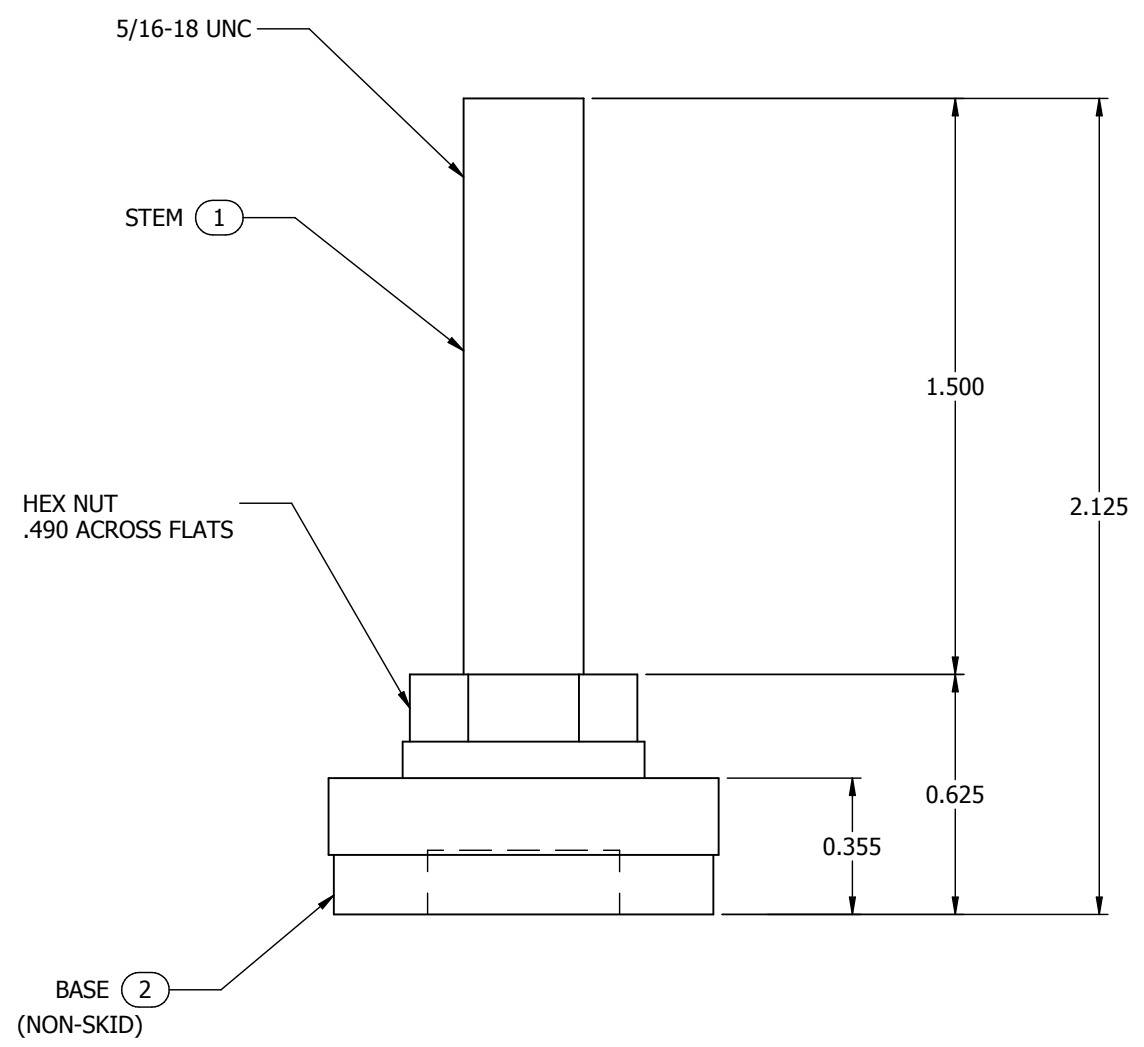
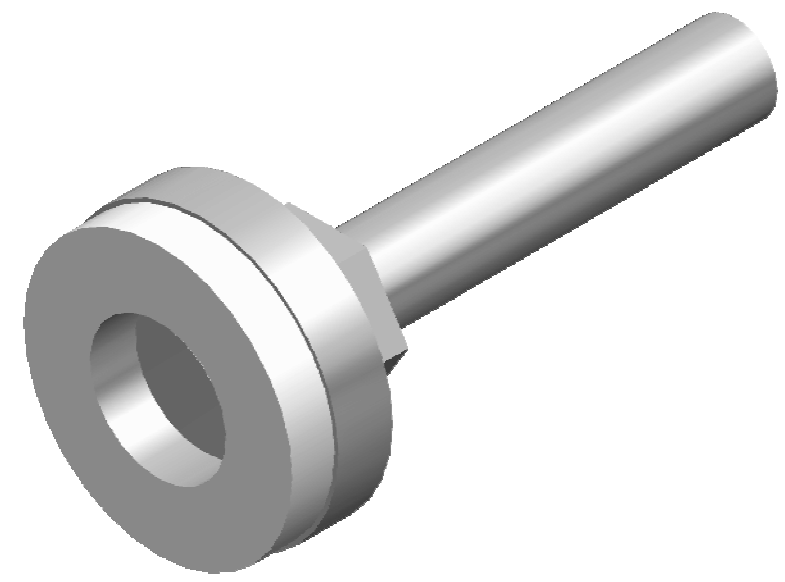
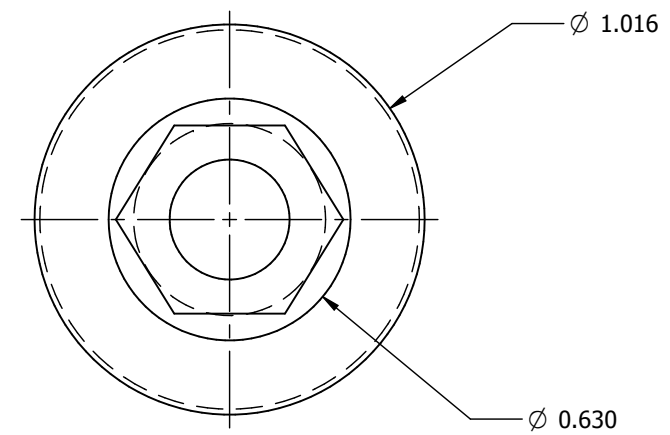

UNLESS OTHERWISE SPECIFIED  
ALL DIMENSIONS ARE SHOWN IN INCHES.

| TOLERANCES - UNLESS OTHERWISE INDICATED: |          |           |          |          |
|--|----------|-----------|----------|----------|
| DIMENSION                                | UNDER 6" | 6" TO 24" | OVER 24" | OVER 48" |
| FRACTION                                 | ± 1/32"  | ± 3/64"   | ± 1/16"  | ± 1/8"   |
| .XX                                      | ± 0.04"  | ± 0.05"   | ± 0.06"  | ± 0.13"  |
| .XXX                                     | ± 0.020" | ± 0.020"  | ± 0.020" | ± 0.030" |
| HOLE Ø                                   | ± 0.005" |           |          |          |
| ANGLE                                    | ± 1°     |           |          |          |

|   |           |   |  |                 |  |
|---|-----------|---|--|-----------------|--|
| N/A   |           | N/A   |  | PART No. CLFKNS |  |
| MODIFIED FROM                               |           | NEXT ASSEMBLY   |  | SHEET SIZE B    |  |
| DWN   | ahalliday | <b>HAMMOND MANUFACTURING CO. LTD</b><br>Enclosure Group   |  |                 |  |
| DATE  | 22-Dec-14 | THIS DRAWING IS PROPRIETARY INFORMATION OF<br>HAMMOND MFG. CO. LTD. NOT TO BE USED WITHOUT EXPRESSED<br>WRITTEN PERMISSION OF HAMMOND MFG. CO. LTD. |  |                 |  |
| CHK.  |           | TITLE: <b>LEVELLING FOOT<br/>NON-SKID</b>   |  |                 |  |
| AUTH.                                       |           | SCALE: 2:1  |  | DWG: CLFKNS     |  |
| MAT'L                                       | N/A       | SHEET: 1 OF 1   |  |                 |  |
| CAD DATA ONLY:<br>DO NOT MANUALLY<br>UPDATE |           |   |  |                 |  |