

(4) EACH #10-32 BRASS INSERTS AND 316 STAINLESS STEEL CAPTIVE COVER SCREWS

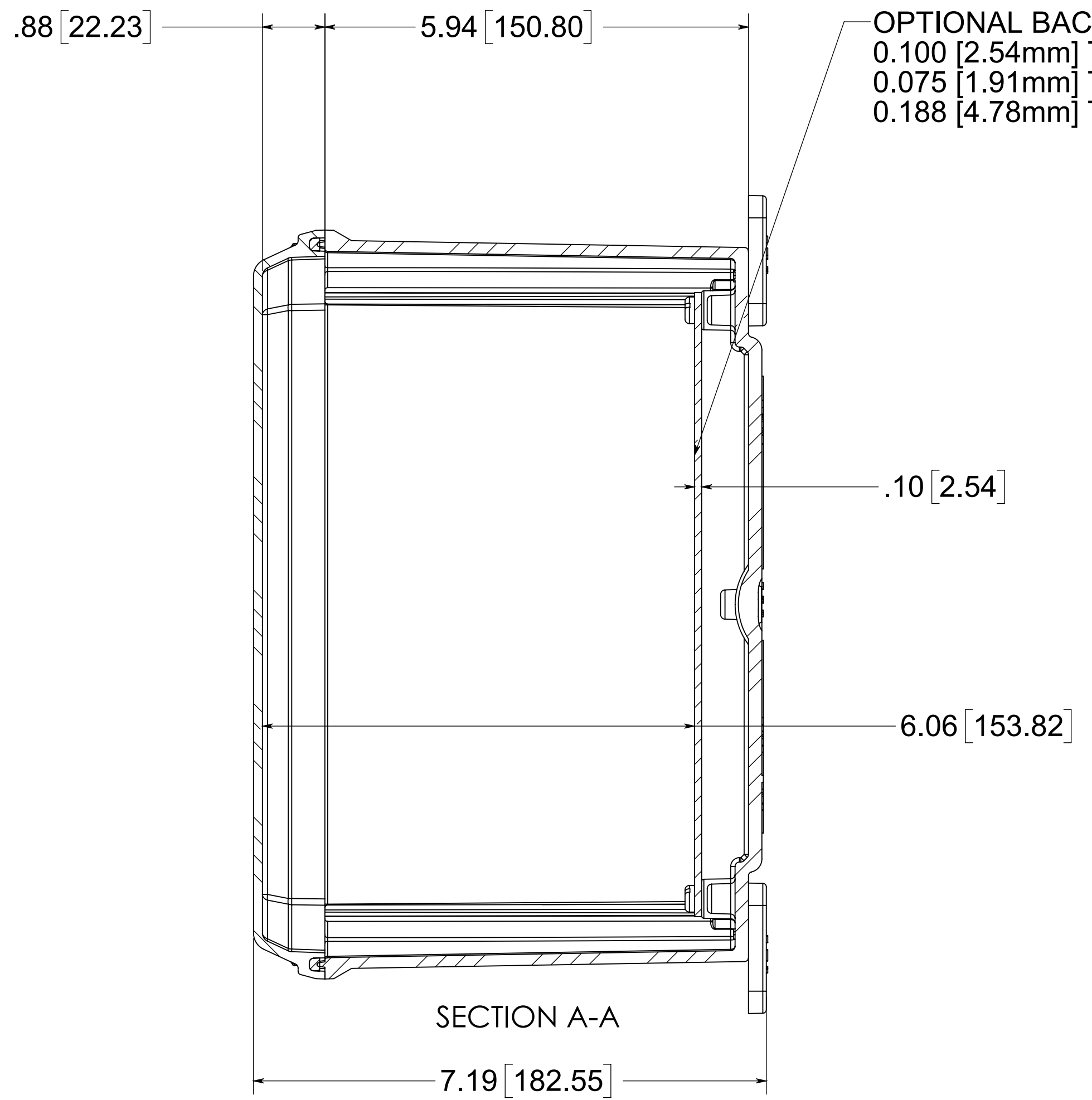

SECTION A-A

OPTIONAL BACK PANEL SHOWN  
 0.100 [2.54mm] TH'K- ALUMINUM  
 0.075 [1.91mm] TH'K- WHITE STEEL  
 0.188 [4.78mm] TH'K- PVC

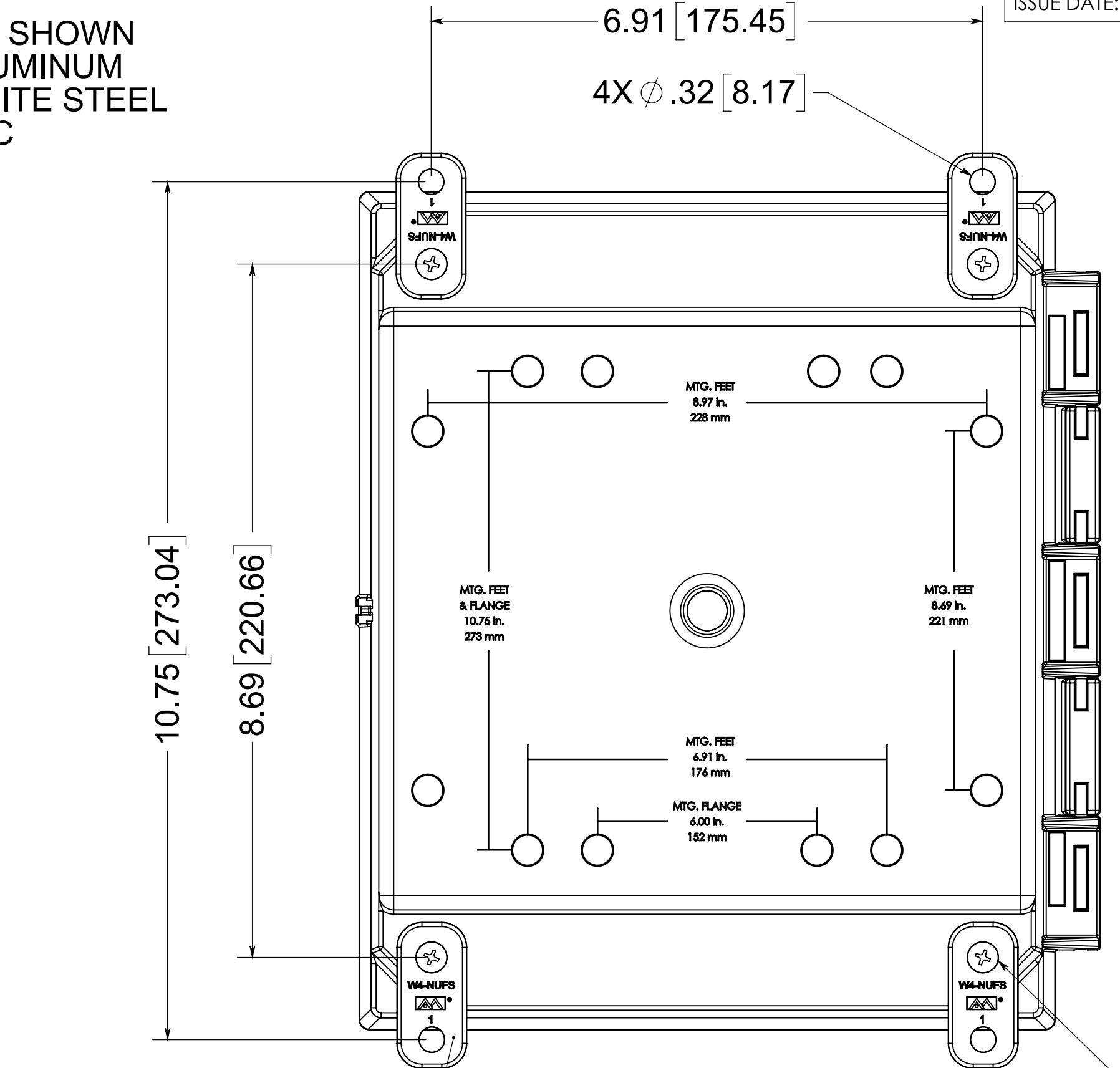

(4) POLYCARBONATE MOUNTING FEET

(4) EACH #10-32 BRASS INSERTS, AND 316 STAINLESS STEEL FLANGE AND FEET SCREWS

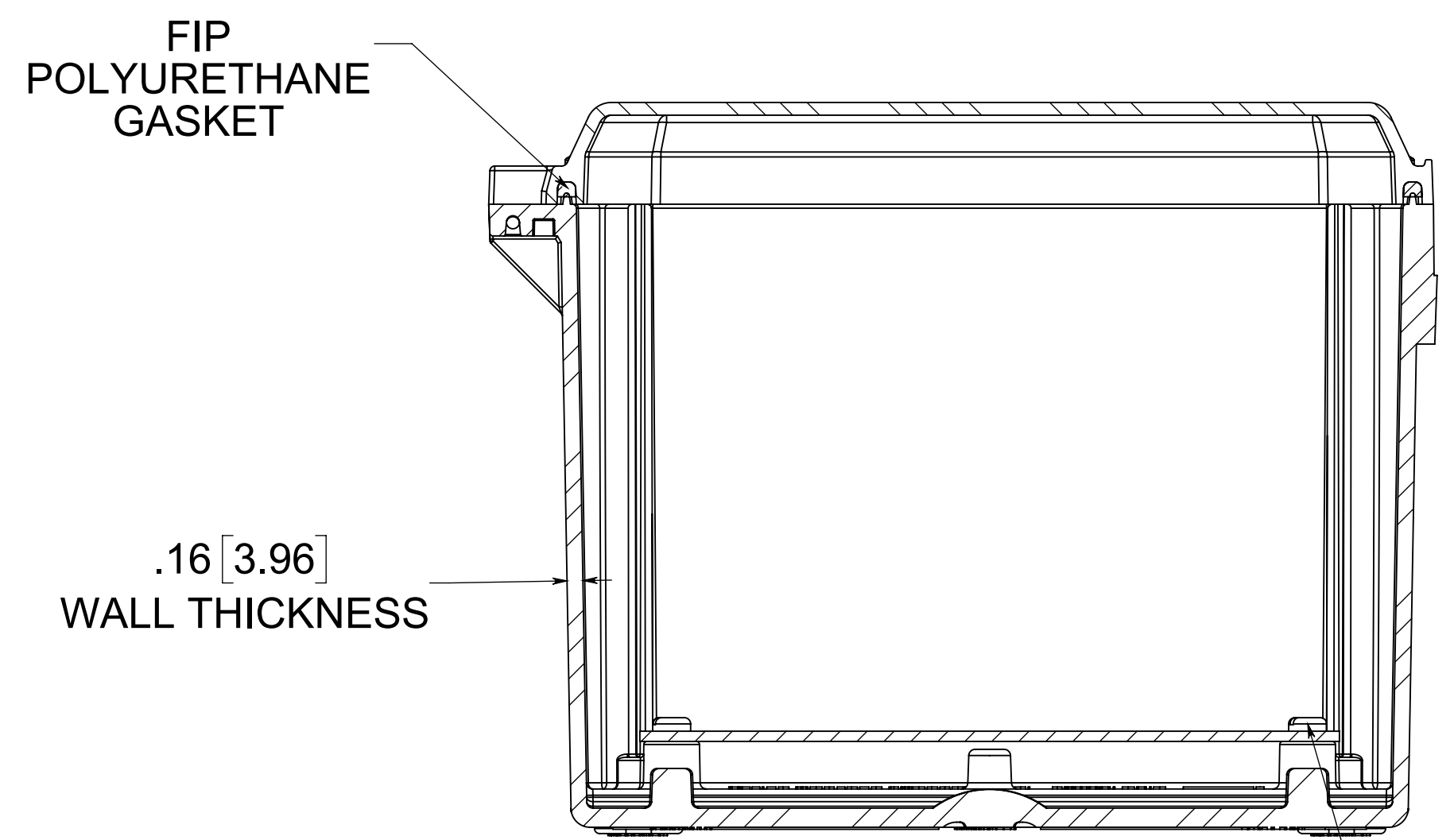

SECTION B-B

MATERIAL:  
 BOX- INJECTED POLYCARBONATE  
 STANDARD COVER- INJECTED POLYCARBONATE  
 CLEAR COVER - INJECTED POLYCARBONATE

(4) EACH #10-32 BRASS INSERTS AND PLATED CARBON STEEL TRUSS SCREW

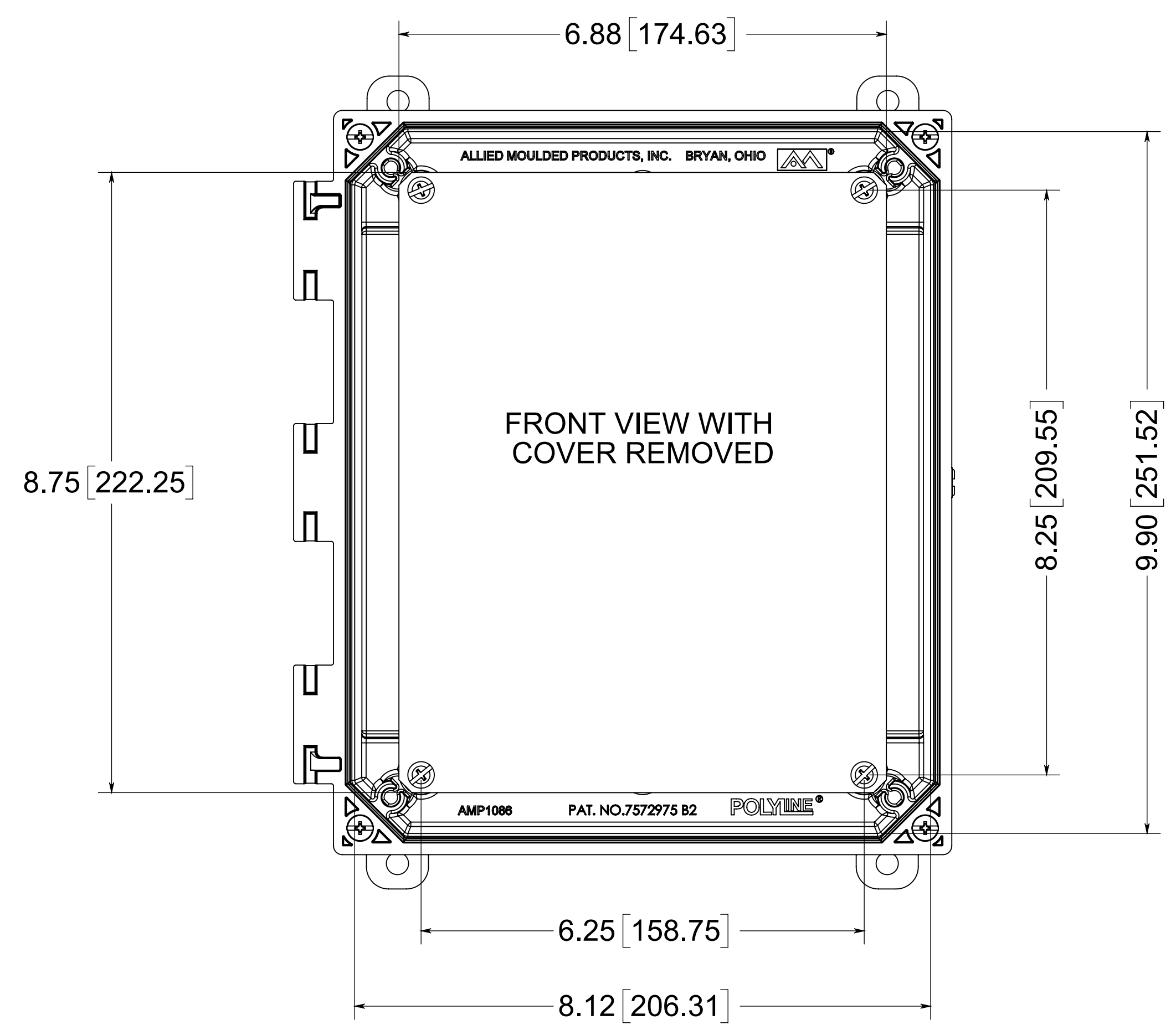

FRONT VIEW WITH COVER REMOVED

NOTE:  
 1. DATA SUBJECT TO CHANGE WITHOUT NOTICE

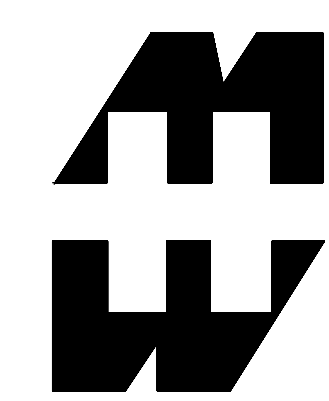

PART No. PCJ1086CC

for more information visit [www.hammfg.com](http://www.hammfg.com)  
 Data subject to change without notice  
 Drawing Not to Scale