

(2) EACH #10-32 BRASS INSERTS AND 316 STAINLESS STEEL CAPTIVE COVER SCREWS

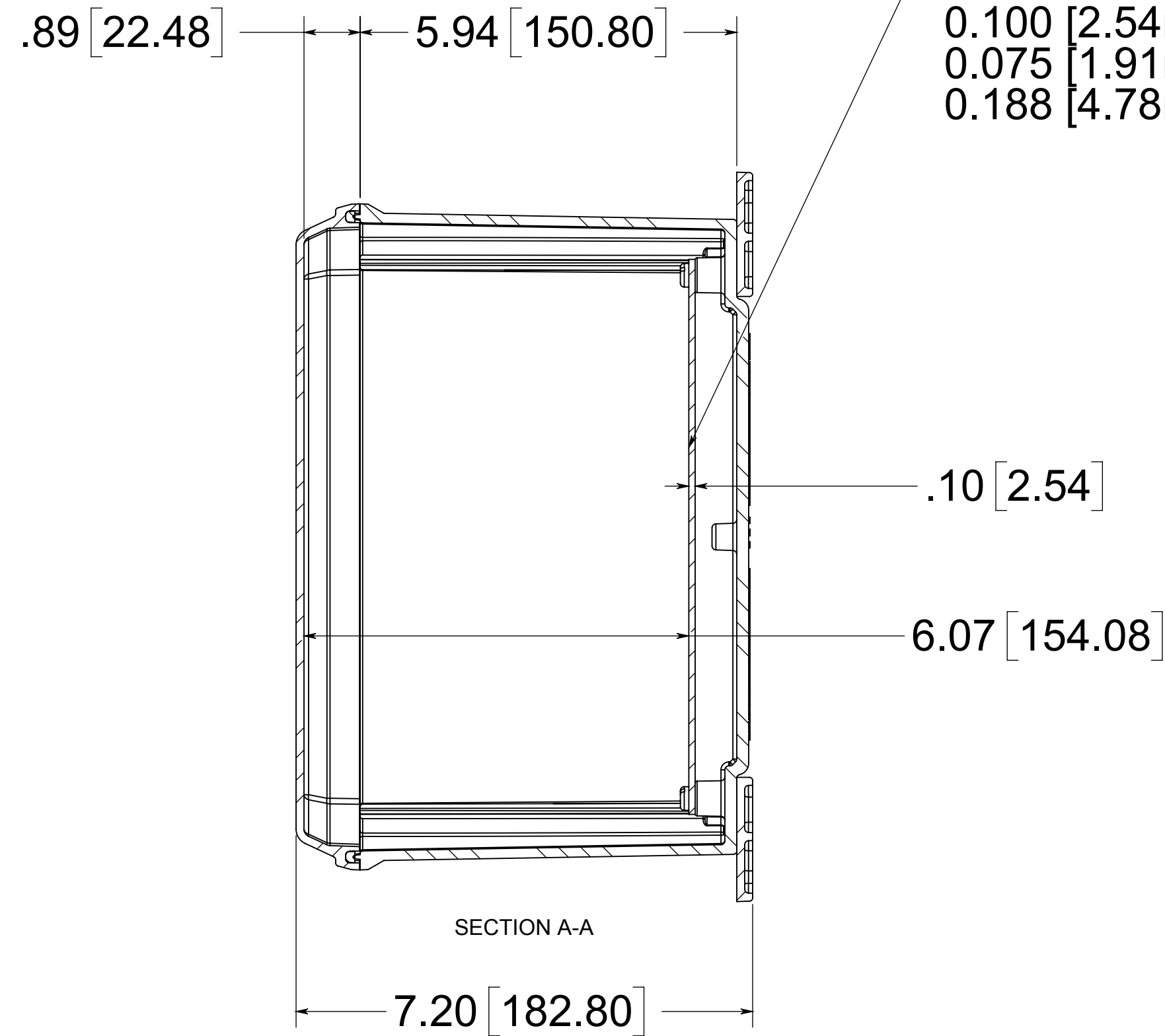

OPTIONAL BACK PANEL SHOWN
 0.100 [2.54mm] TH'K- ALUMINUM
 0.075 [1.91mm] TH'K- WHITE STEEL
 0.188 [4.78mm] TH'K- PVC

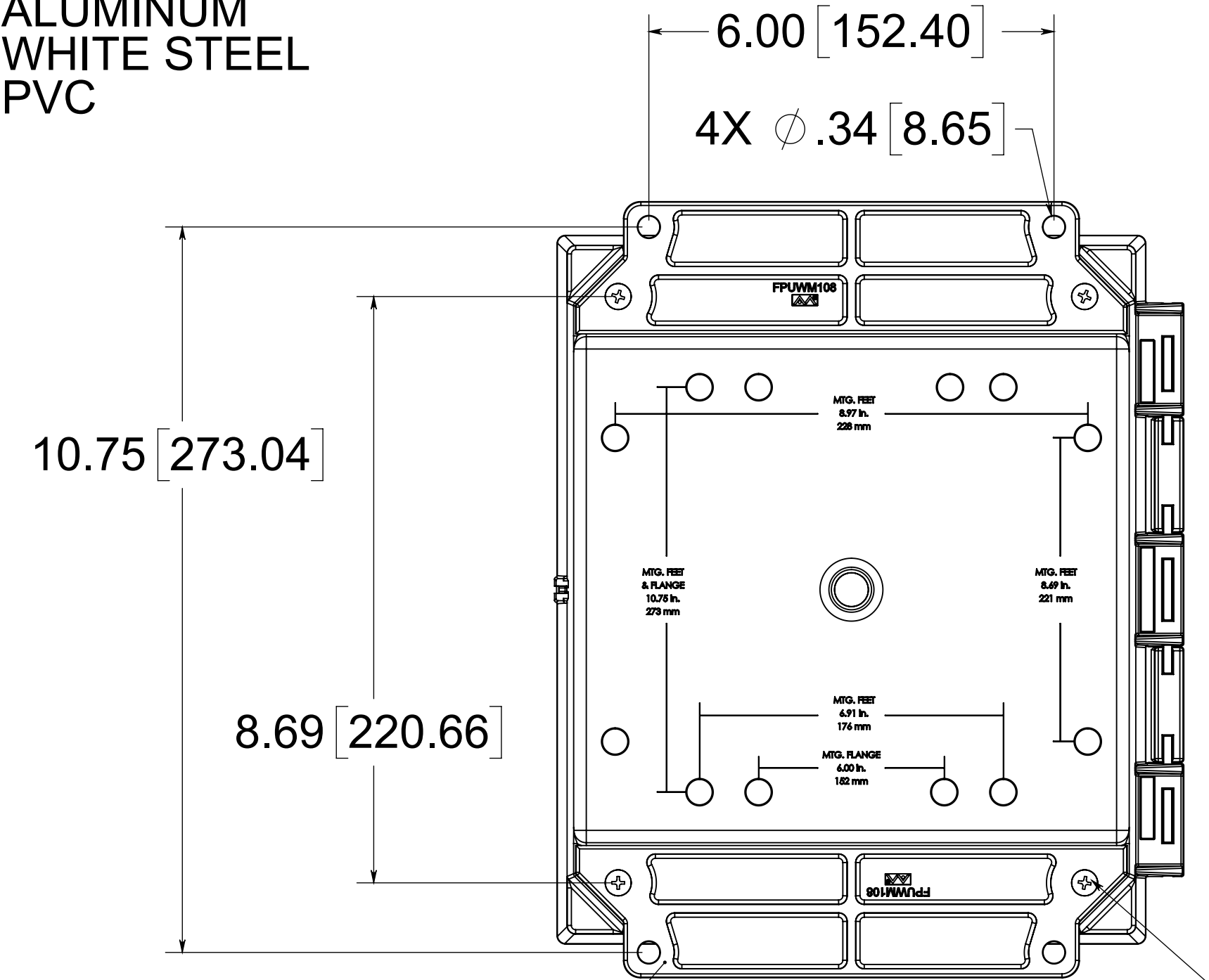

(2) POLYCARBONATE FLANGES (GLUED)

(4) EACH #10-32 BRASS INSERTS, AND 316 STAINLESS STEEL FLANGE AND FEET SCREWS

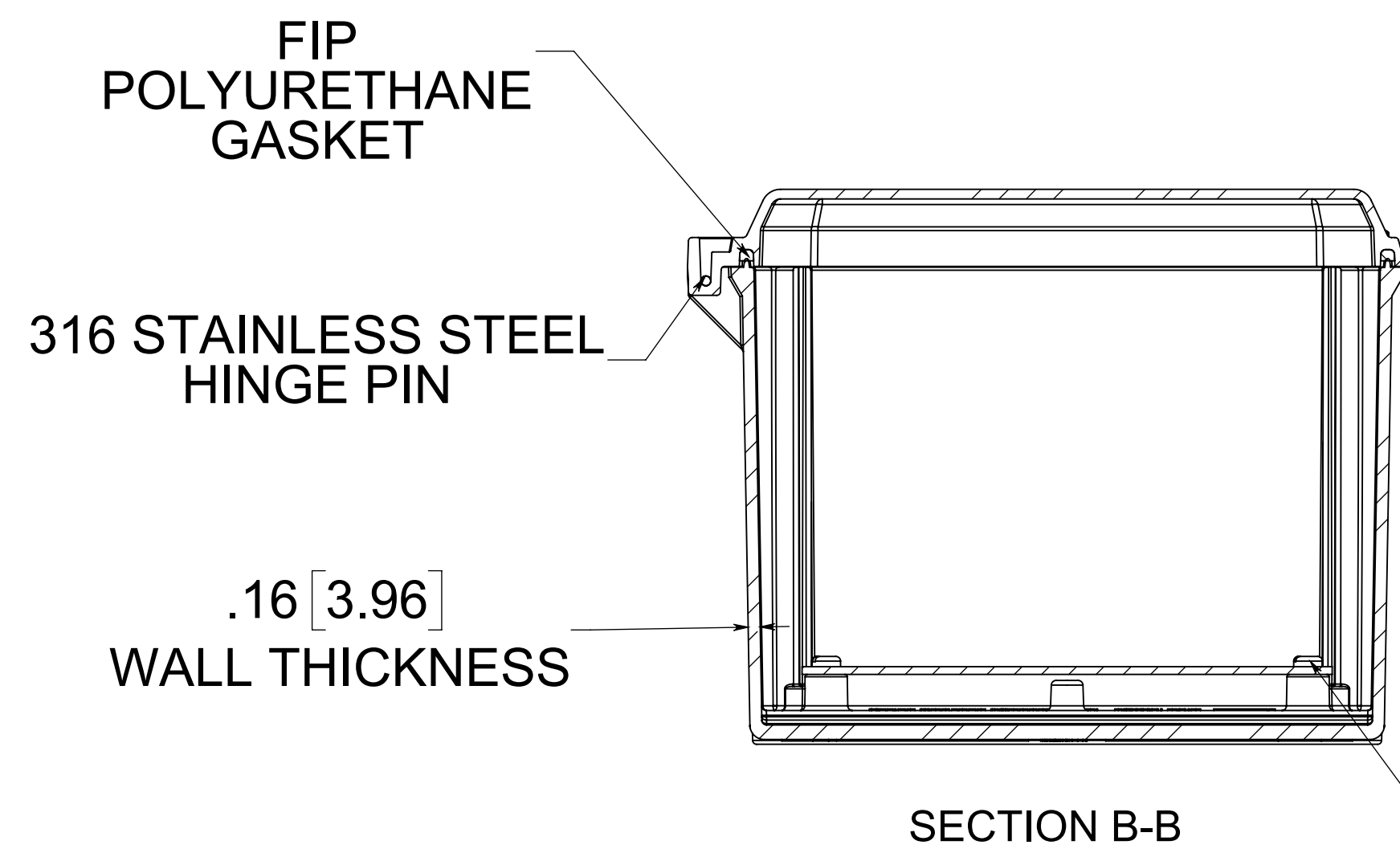

SECTION B-B

(4) EACH #10-32 BRASS INSERTS AND PLATED CARBON STEEL TRUSS SCREW

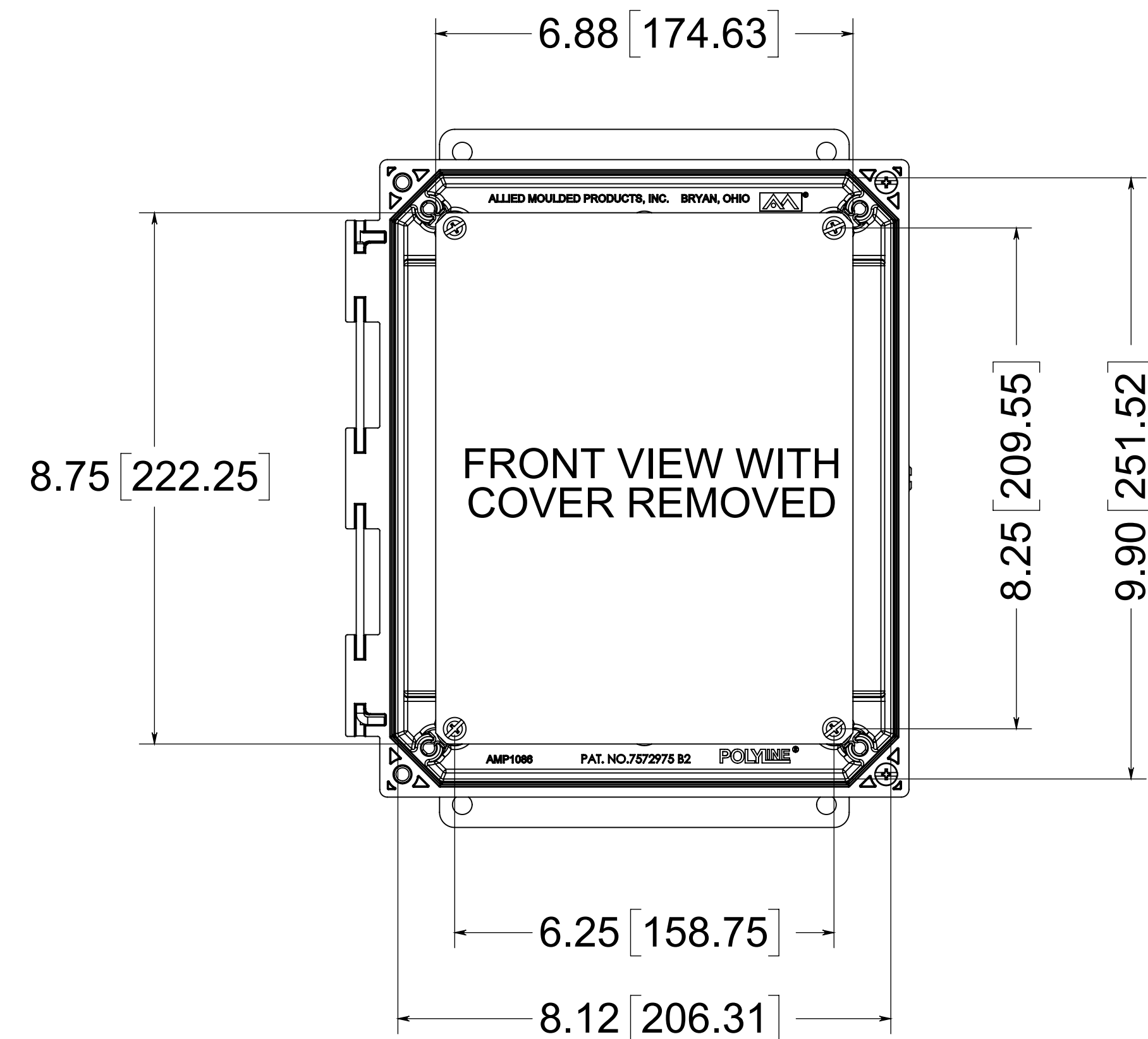

NOTE:
 1. DATA SUBJECT TO CHANGE WITHOUT NOTICE

MATERIAL:
 BOX- INJECTED POLYCARBONATE
 STANDARD COVER- INJECTED POLYCARBONATE
 CLEAR COVER - INJECTED POLYCARBONATE

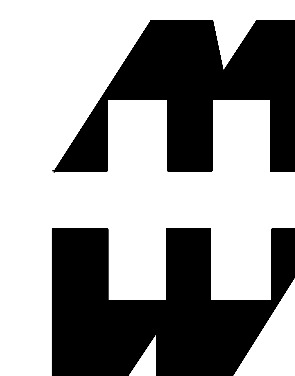

PART No. PCJ1086HF

for more information visit
www.hammfg.com
 Data subject to change without notice

Drawing Not to Scale