

(2X) EACH #10-32 BRASS INSERTS AND 316 STAINLESS STEEL CAPTIVE COVER SCREWS

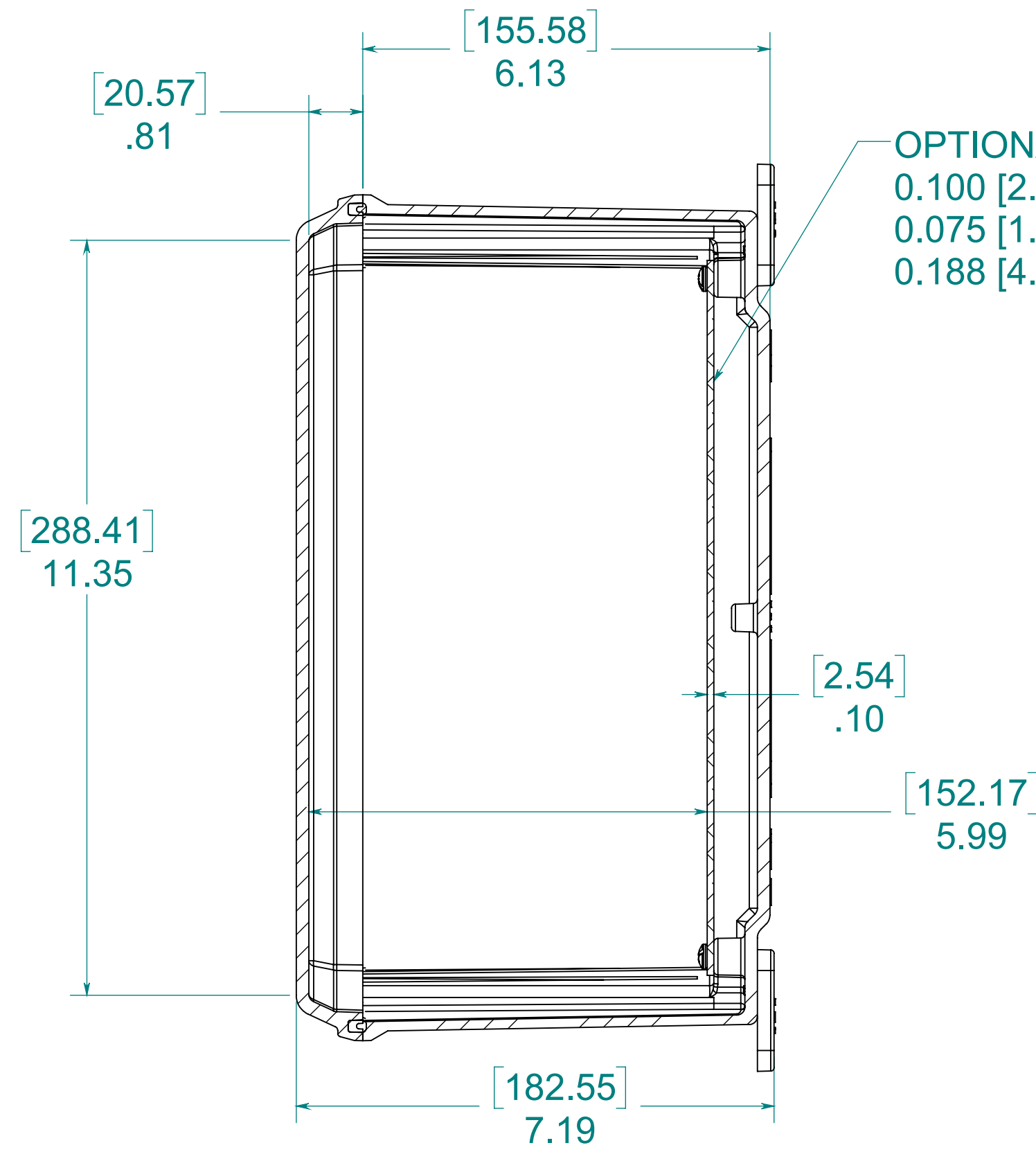

SECTION A-A

OPTIONAL BACK PANEL SHOWN  
 0.100 [2.54mm] TH'K- ALUMINUM  
 0.075 [1.91mm] TH'K- WHITE STEEL  
 0.188 [4.78mm] TH'K- PVC

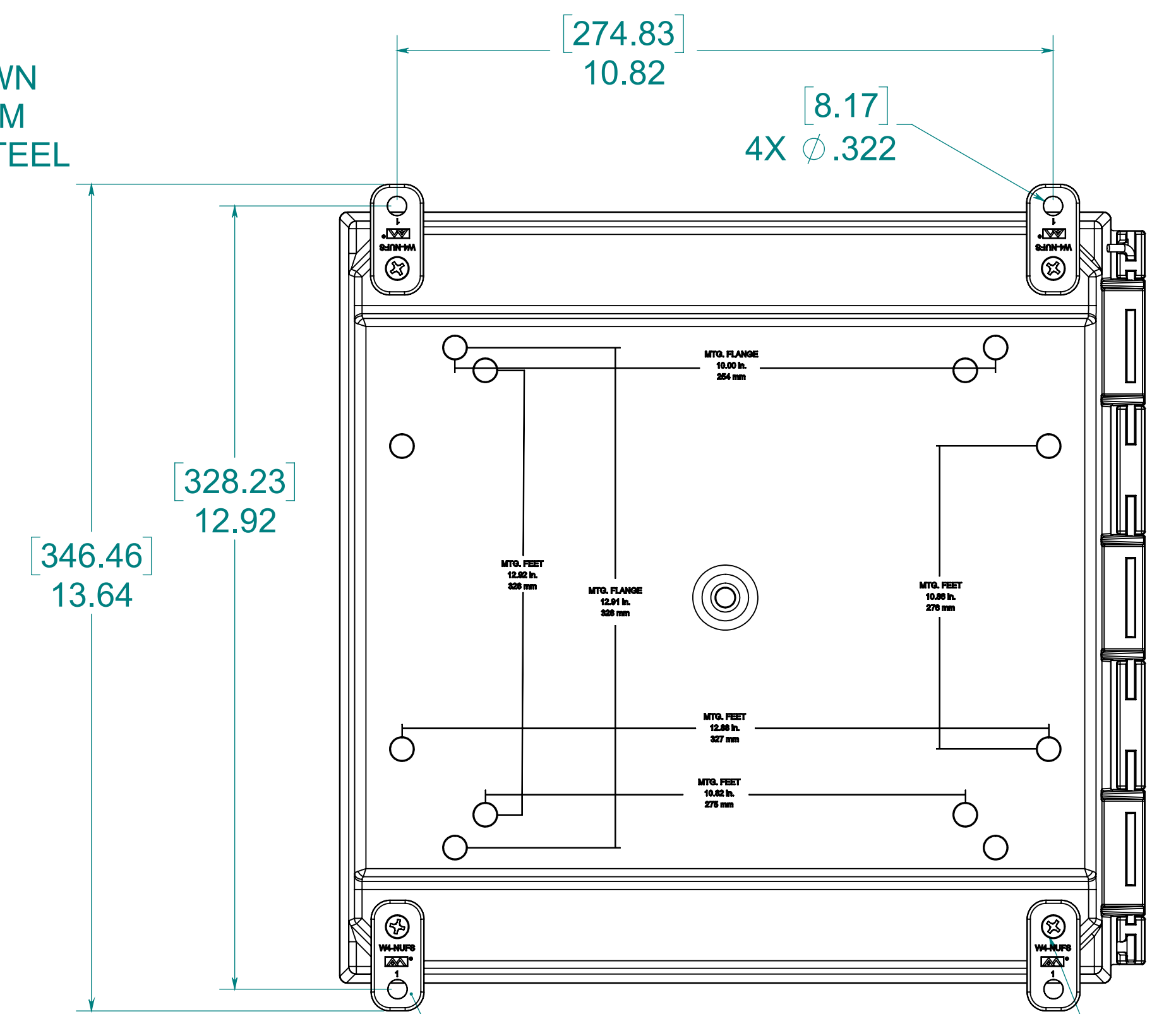

(4X) EACH #10-32 BRASS INSERTS AND 316 STAINLESS STEEL FEET SCREWS

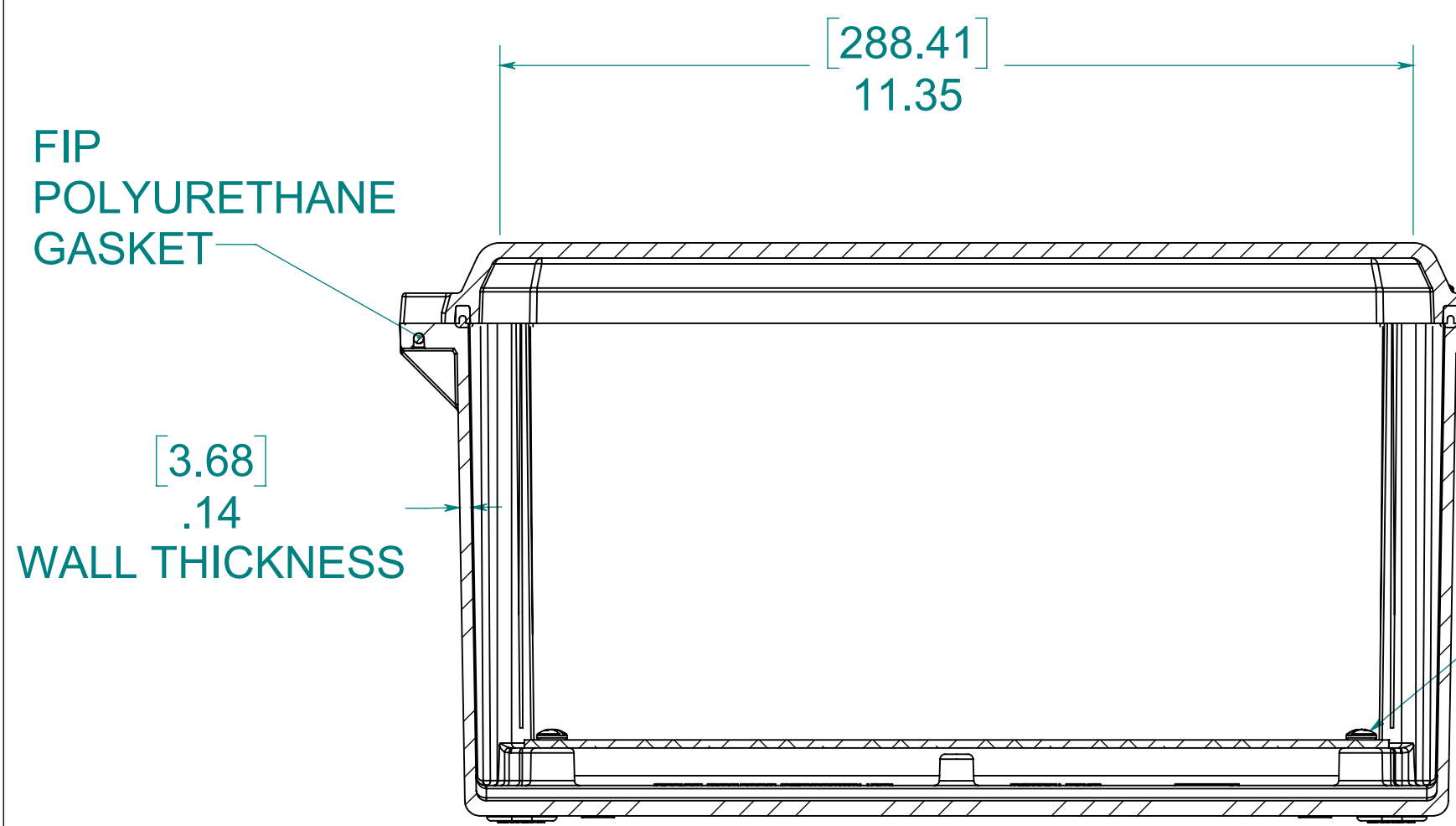

SECTION B-B

FIP POLYURETHANE GASKET

WALL THICKNESS

(4X) EACH #10-32 BRASS INSERTS AND PLATED CARBON STEEL SCREWS

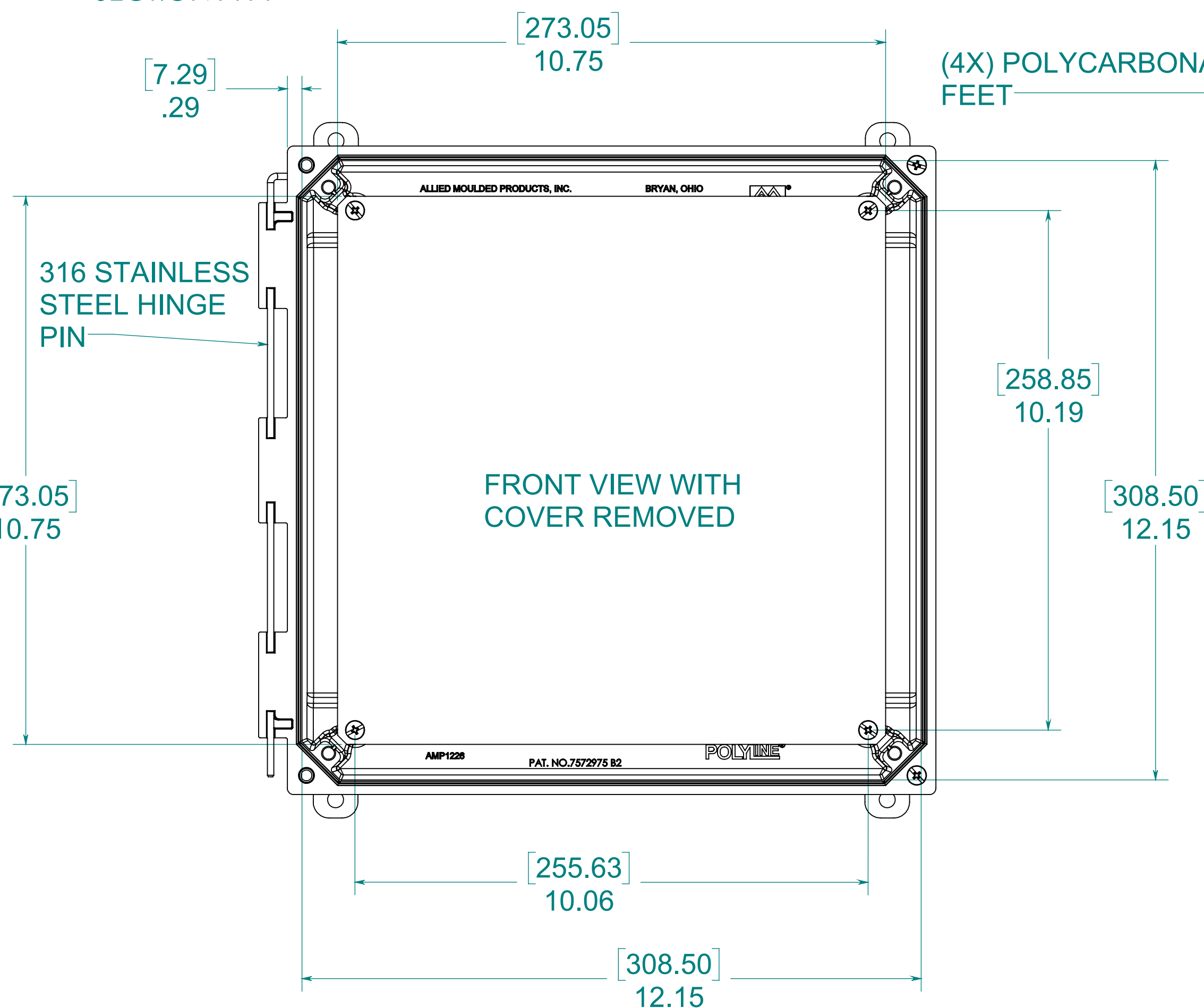

FRONT VIEW WITH COVER REMOVED

(4X) POLYCARBONATE FEET

316 STAINLESS STEEL HINGE PIN

MATERIAL:  
 BOX- INJECTED POLYCARBONATE  
 STANDARD COVER- INJECTED POLYCARBONATE  
 CLEAR COVER- INJECTED POLYCARBONATE

NOTE:  
 1. DATA SUBJECT TO CHANGE WITHOUT NOTICE

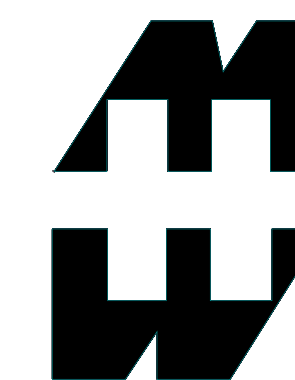

PART No. PCJ12126CCH

for more information visit  
[www.hammfg.com](http://www.hammfg.com)  
 Data subject to change without notice

Drawing Not to Scale