

STAINLESS STEEL HINGE PIN

(2) EACH #10-32 BRASS INSERTS AND STAINLESS STEEL CAPTIVE COVER SCREWS WITH RETAINING O-RING

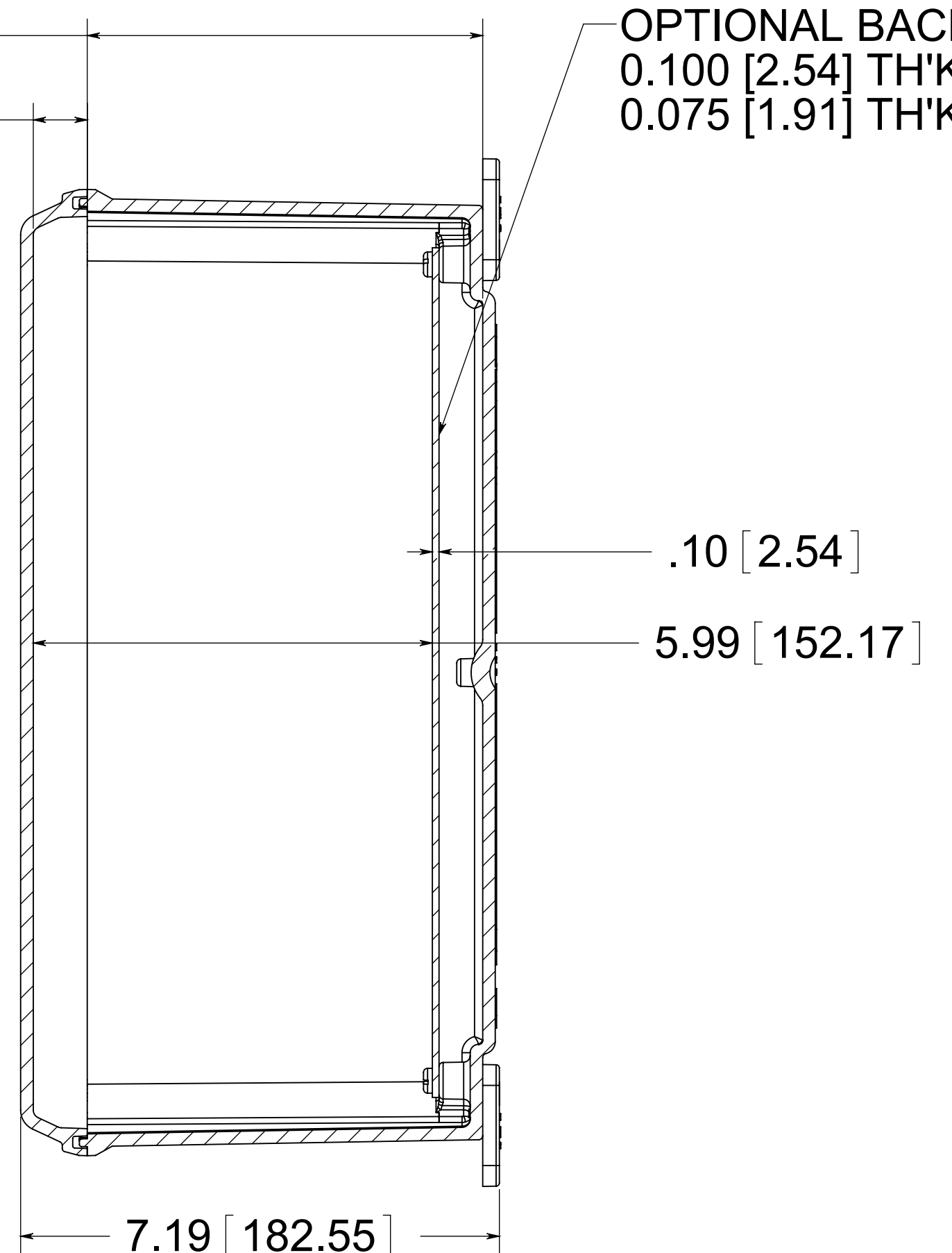

SECTION A-A

OPTIONAL BACK PANEL
0.100 [2.54] TH'K- ALUMINUM
0.075 [1.91] TH'K- WHITE STEEL

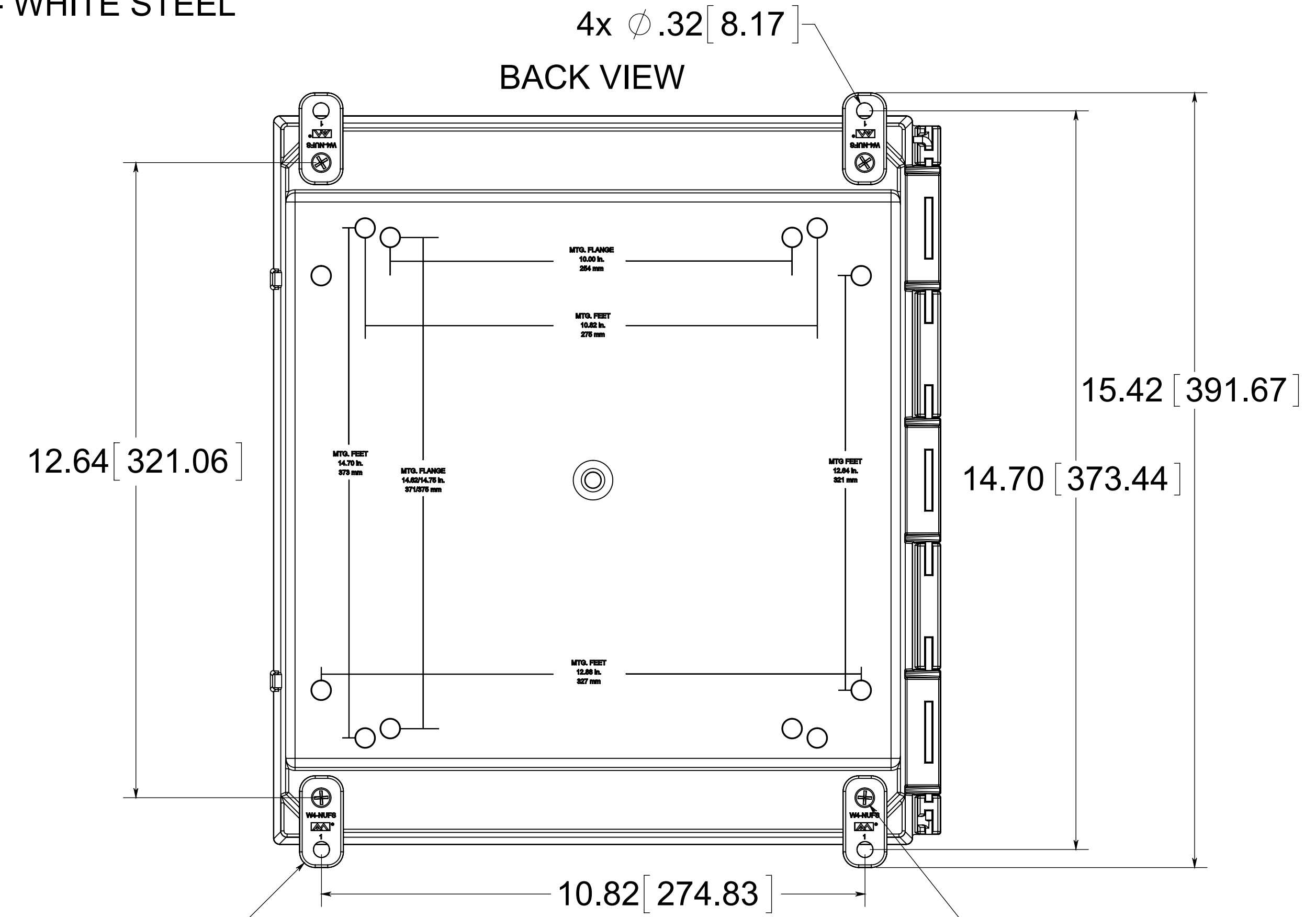

(4) POLYCARBONATE FEET

(4) EACH #10-32 BRASS INSERTS, AND STAINLESS STEEL FLANGE AND FEET SCREWS

FRONT VIEW WITH COVER REMOVED AND BACK PANEL DISPLAYED

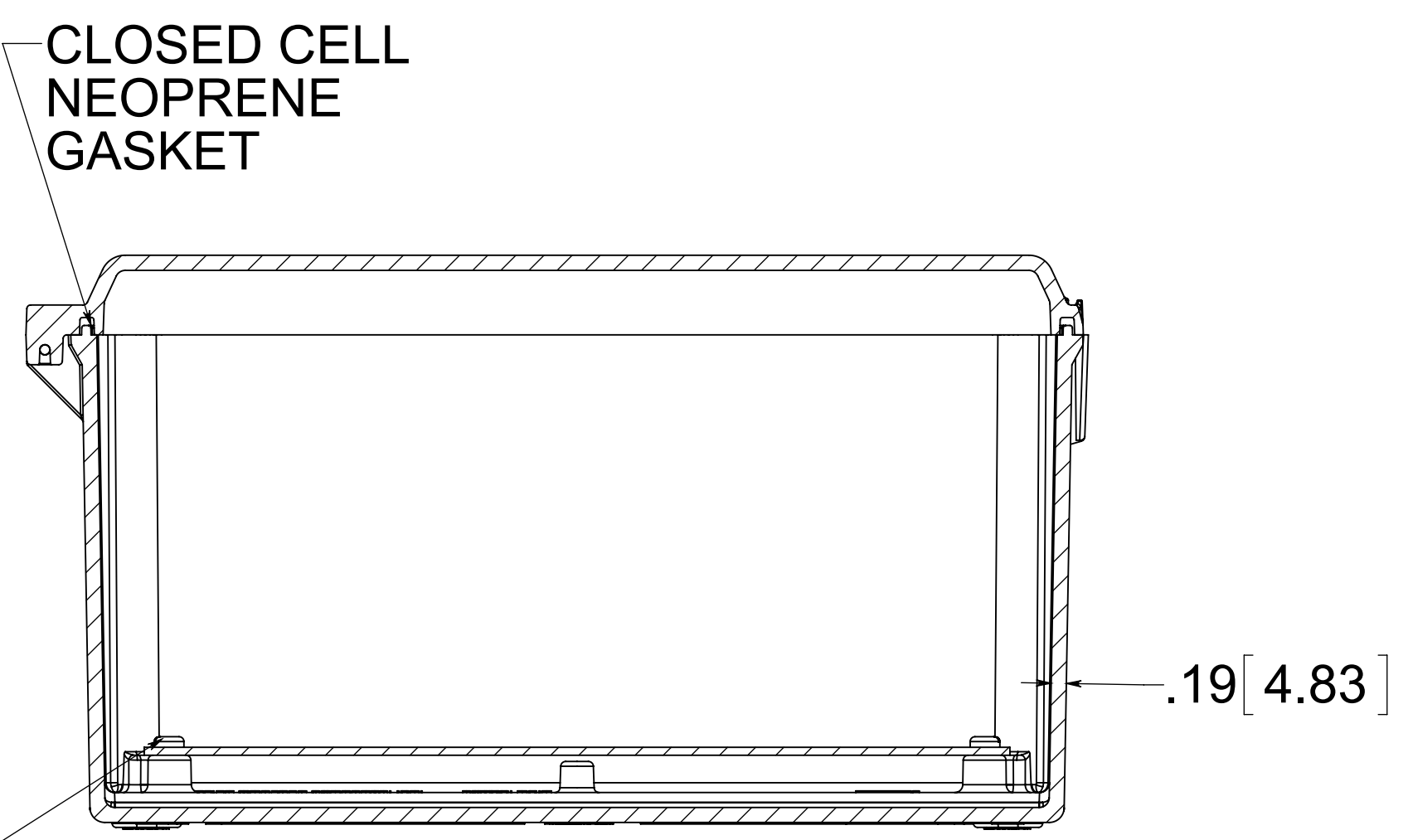

SECTION B-B

(4) EACH #10-32 BRASS INSERTS AND PLATED CARBON STEEL TRUSS SCREWS

MATERIAL:
BOX- INJECTED POLYCARBONATE
STANDARD COVER- INJECTED POLYCARBONATE
CLEAR COVER - INJECTED POLYCARBONATE

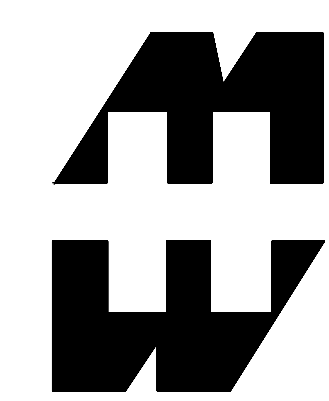
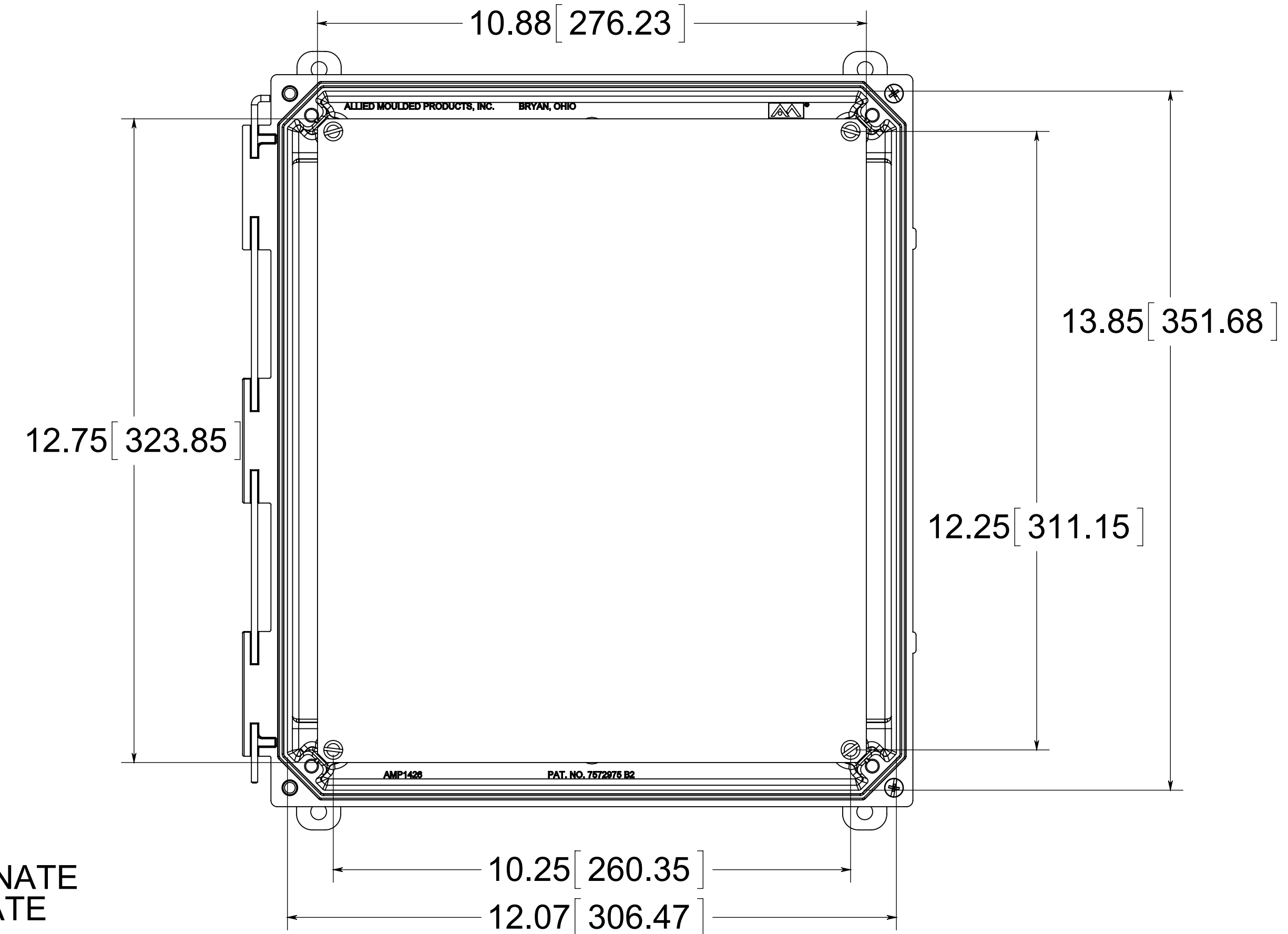

PART No. PCJ14126H
for more information visit www.hammfg.com
Data subject to change without notice
Drawing Not to Scale