

OPTIONAL BACK PANEL SHOWN
 0.100 [2.54] TH'K - ALUMINUM
 0.075 [1.91] TH'K - WHITE STEEL
 0.188 [4.78] TH'K - PVC

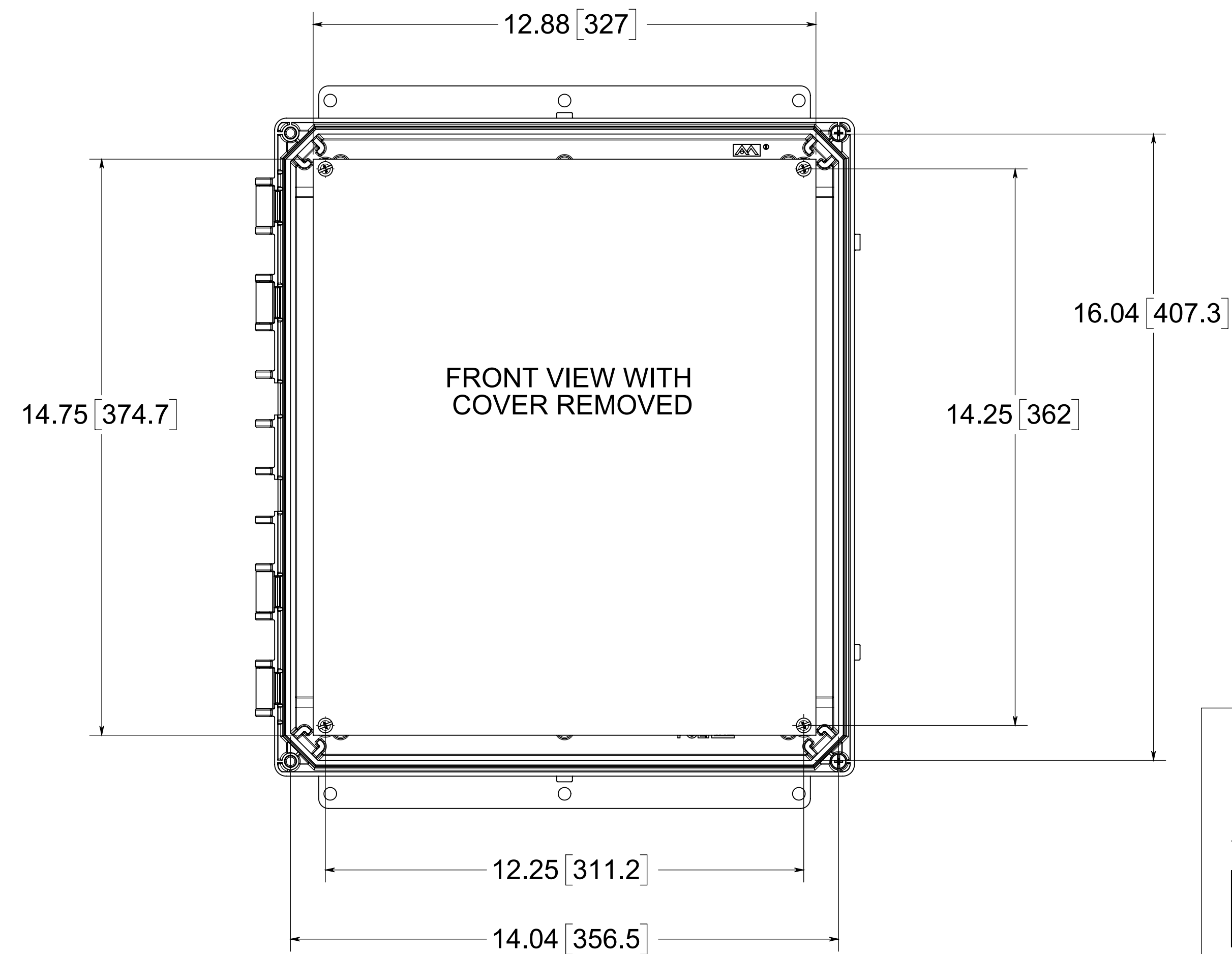

NOTE:
 1. DATA SUBJECT TO CHANGE

MATERIAL:
 BOX - INJECTED POLYCARBONATE
 STANDARD COVER - INJECTED POLYCARBONATE
 CLEAR COVER - INJECTED POLYCARBONATE

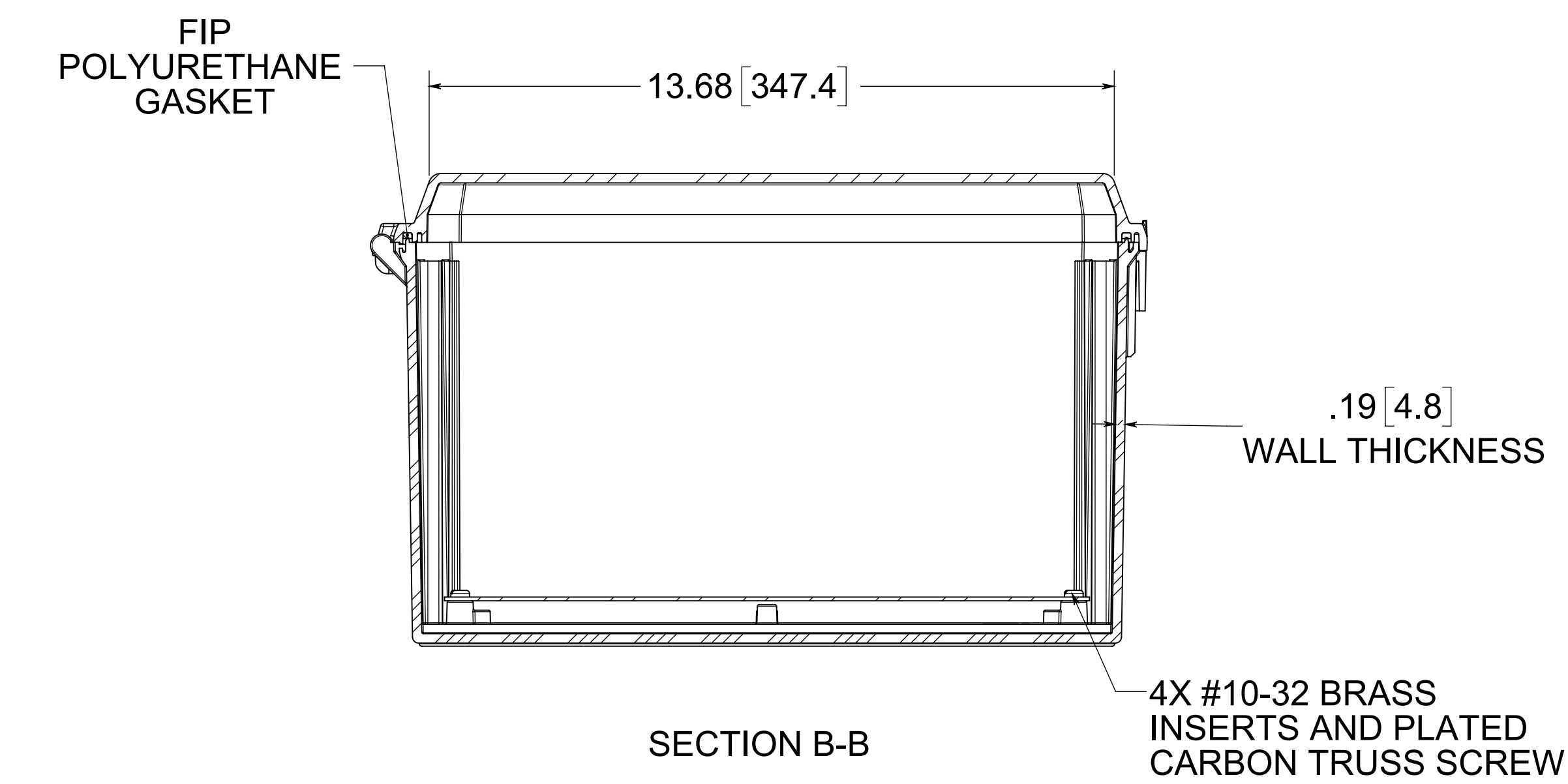
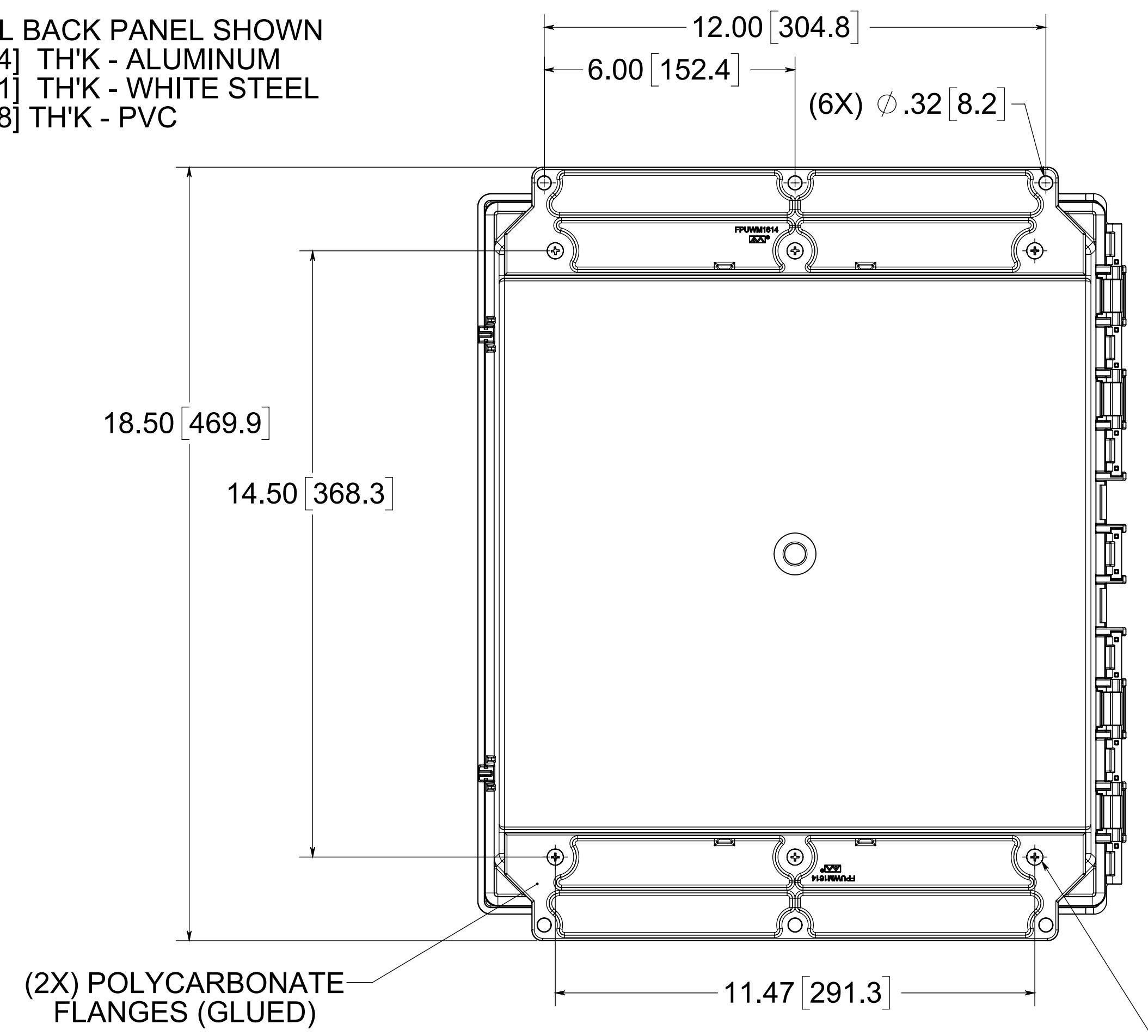
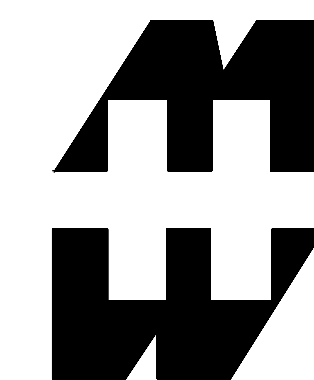

PART No. PCJ16148CCHF

for more information visit
www.hammfg.com
 Data subject to change without notice

Drawing Not to Scale