

(4) EACH #10-32 BRASS INSERTS AND STAINLESS STEEL CAPTIVE COVER SCREWS WITH RETAINING O-RING

FIP POLYURETHANE FOAM GASKET

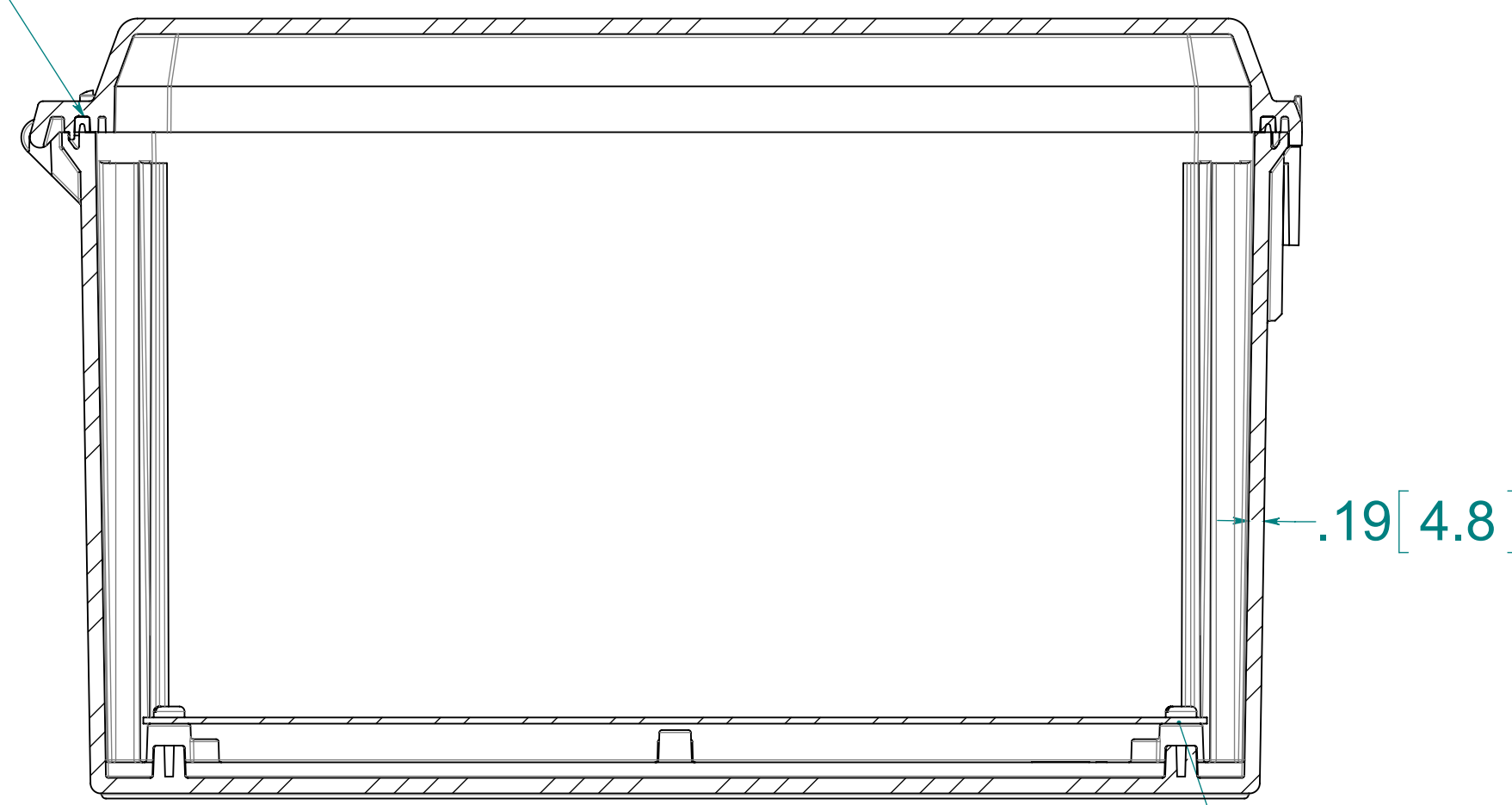

SECTION D-D

(4) EACH #10-32 BRASS INSERTS PLATED CARBON STEEL SCREWS TO RETAIN BACK PANEL

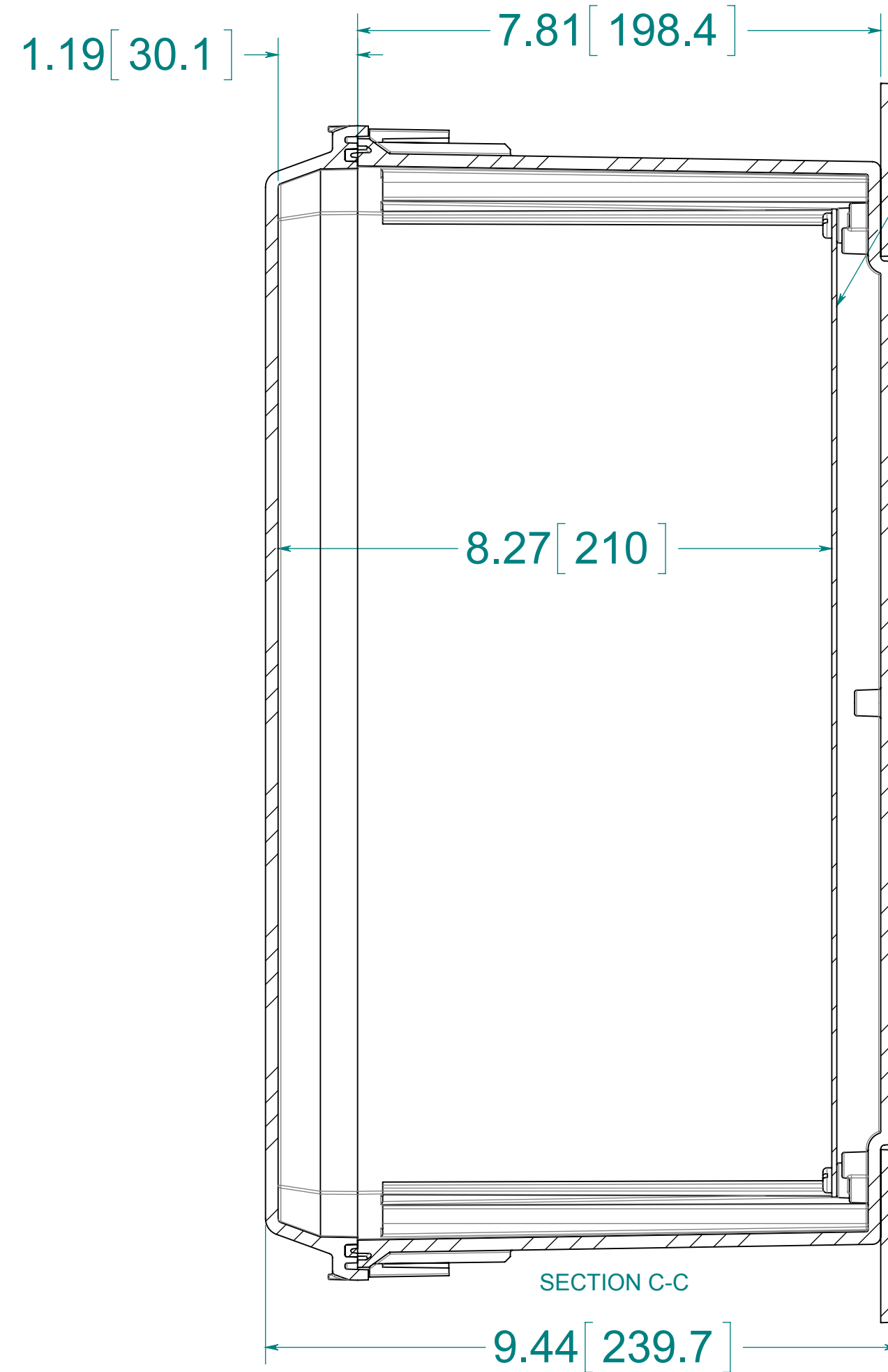

SECTION C-C

OPTIONAL BACK PANEL
.100[2.54] TH'K - ALUMINUM
.075[1.91] TH'K - PAINTED STEEL

(2) POLYCARBONATE FLANGE

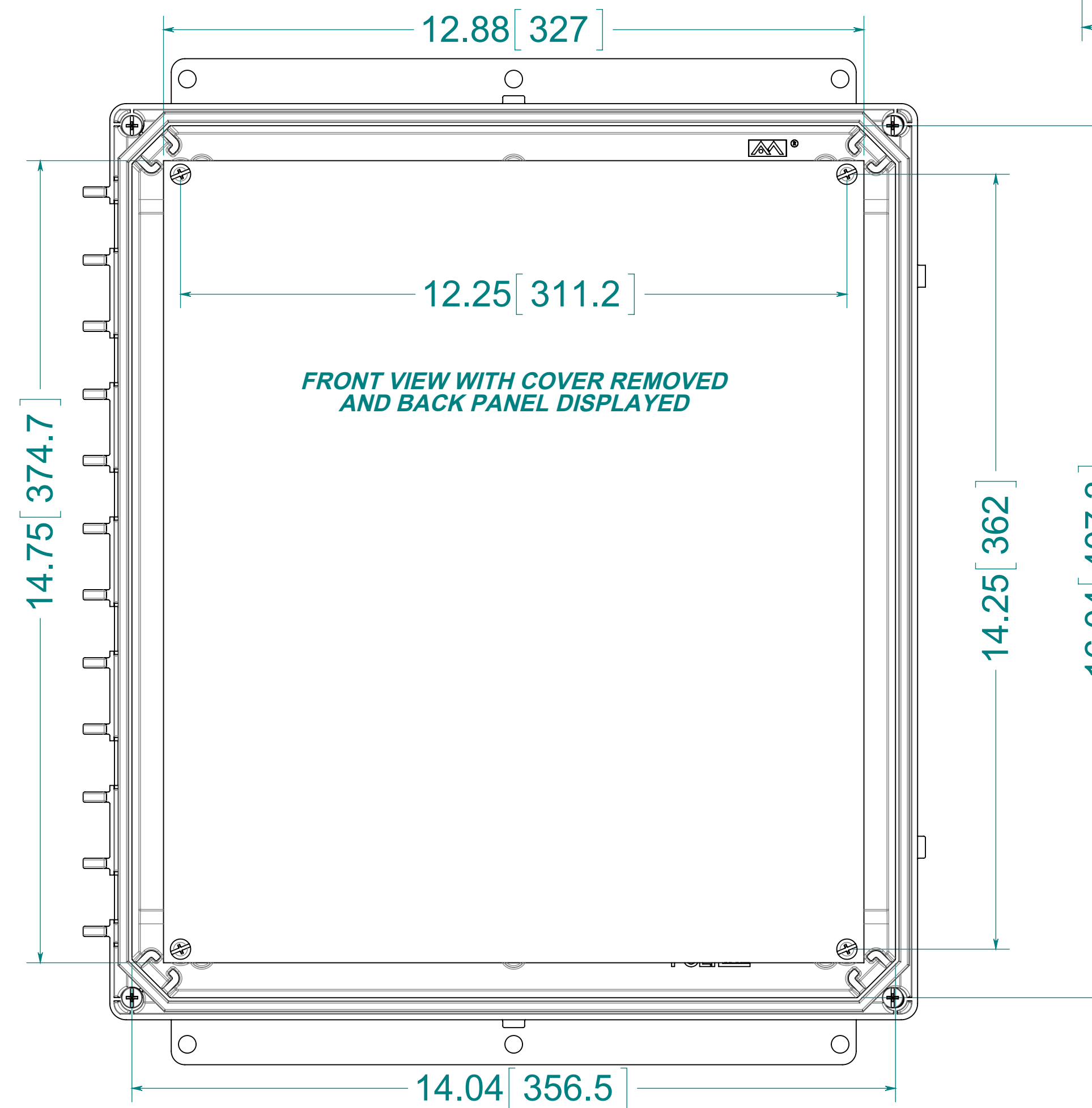

FRONT VIEW WITH COVER REMOVED AND BACK PANEL DISPLAYED

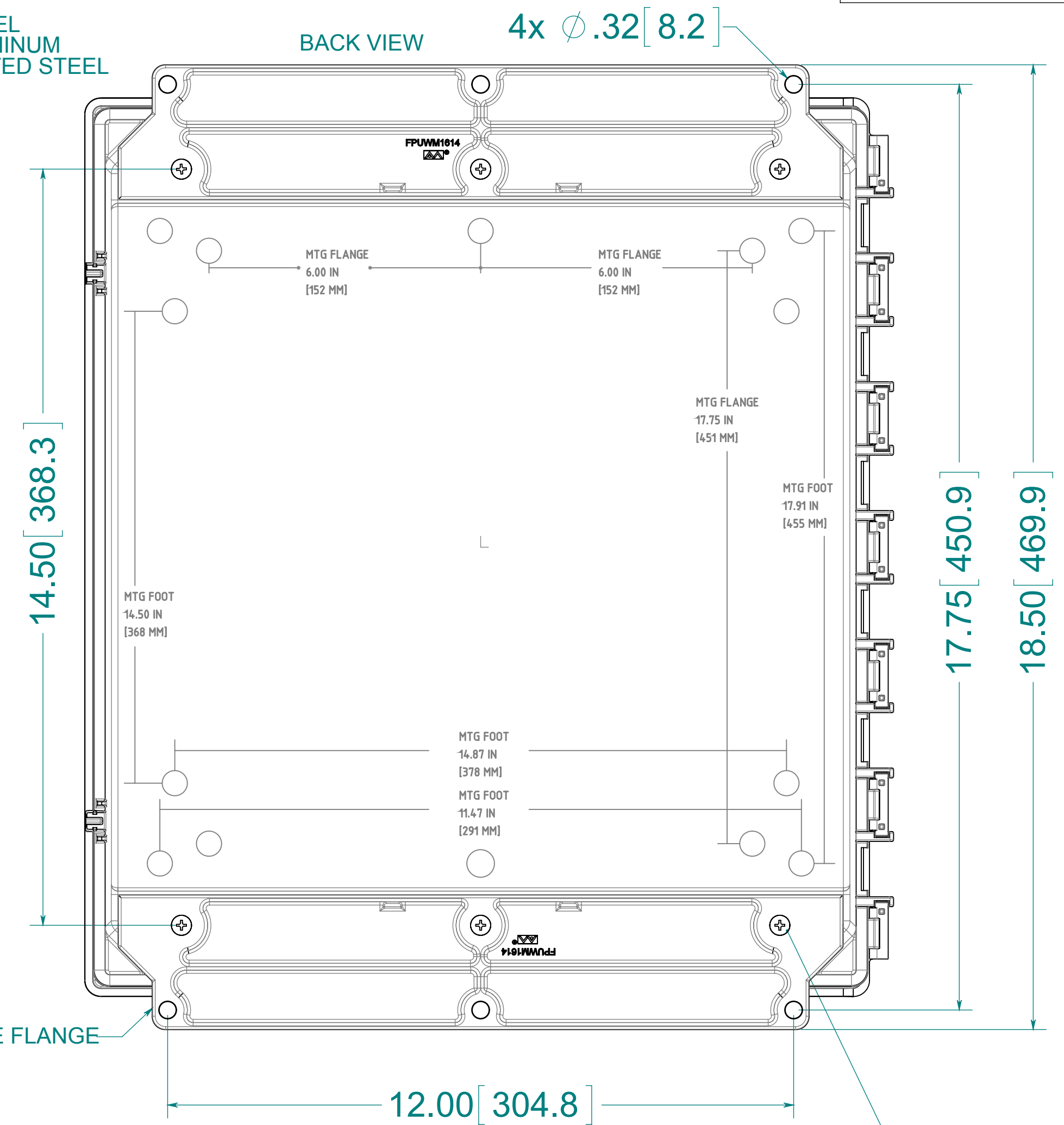

BACK VIEW

4x Ø .32 [8.2]

MTG FLANGE
6.00 IN
[152 MM]

MTG FLANGE
6.00 IN
[152 MM]

MTG FLANGE
17.75 IN
[451 MM]

MTG FOOT
17.91 IN
[455 MM]

MTG FOOT
14.50 IN
[368 MM]

MTG FOOT
14.87 IN
[378 MM]

MTG FOOT
11.47 IN
[291 MM]

(4) EACH #10-32 BRASS INSERTS AND STAINLESS STEEL FLANGE AND FEET SCREWS

MATERIAL:
BOX: INJECTION MOLDED POLYCARBONATE
STANDARD COVER: INJECTION MOLDED POLYCARBONATE
CLEAR COVER: INJECTION MOLDED POLYCARBONATE

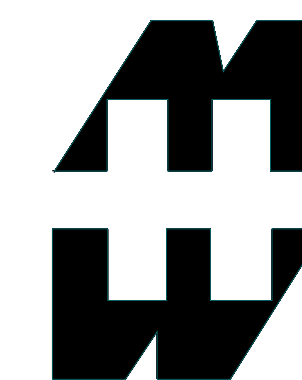

PART No. PCJ16148F

for more information visit
www.hammfg.com
Data subject to change without notice

Drawing Not to Scale