

(4) EACH #10-32 BRASS INSERTS AND STAINLESS STEEL CAPTIVE COVER SCREWS WITH RETAINING O-RING

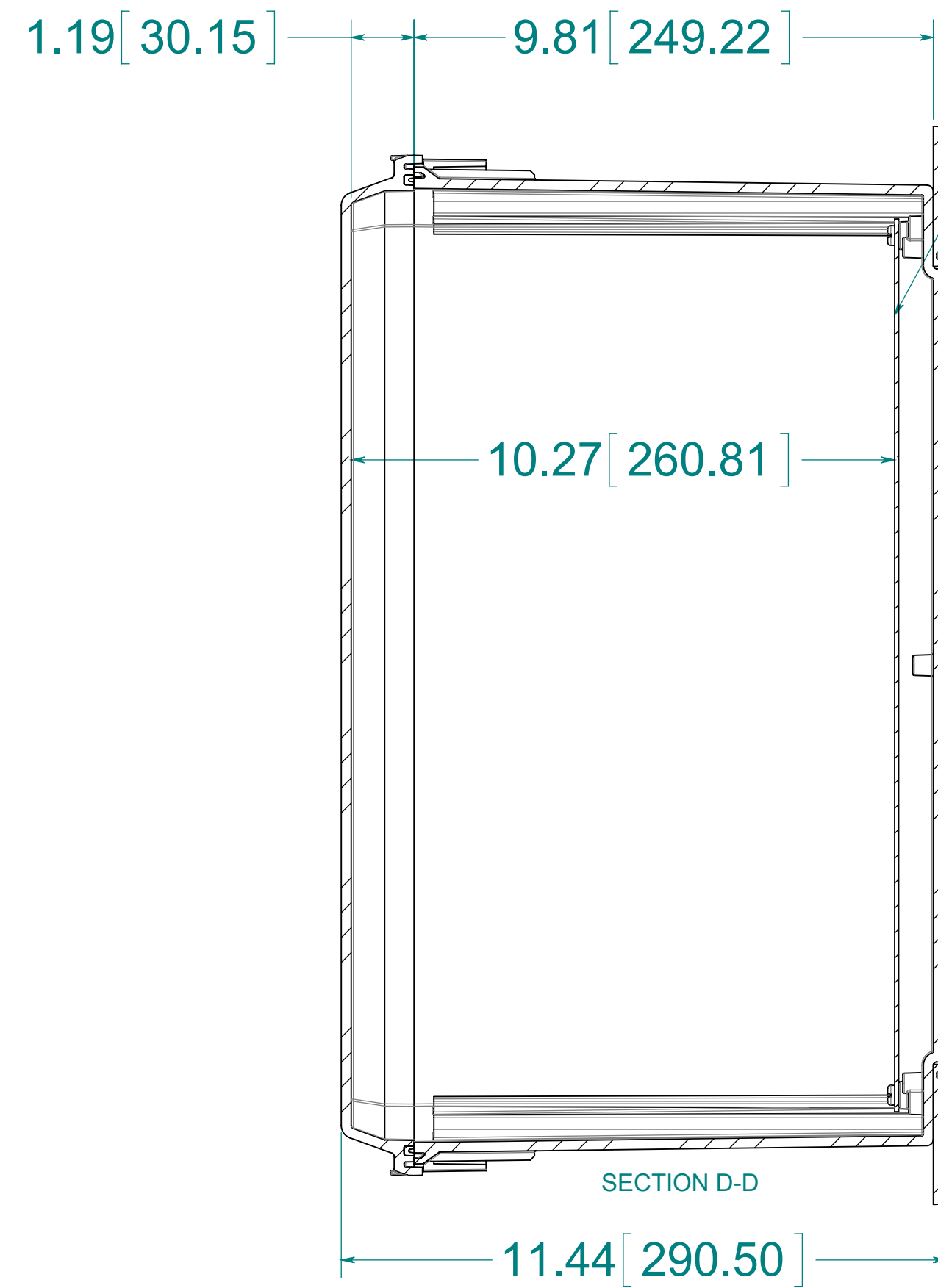

OPTIONAL BACK PANEL  
 .100[2.54] TH'K - ALUMINUM  
 .075[1.91] TH'K - PAINTED STEEL

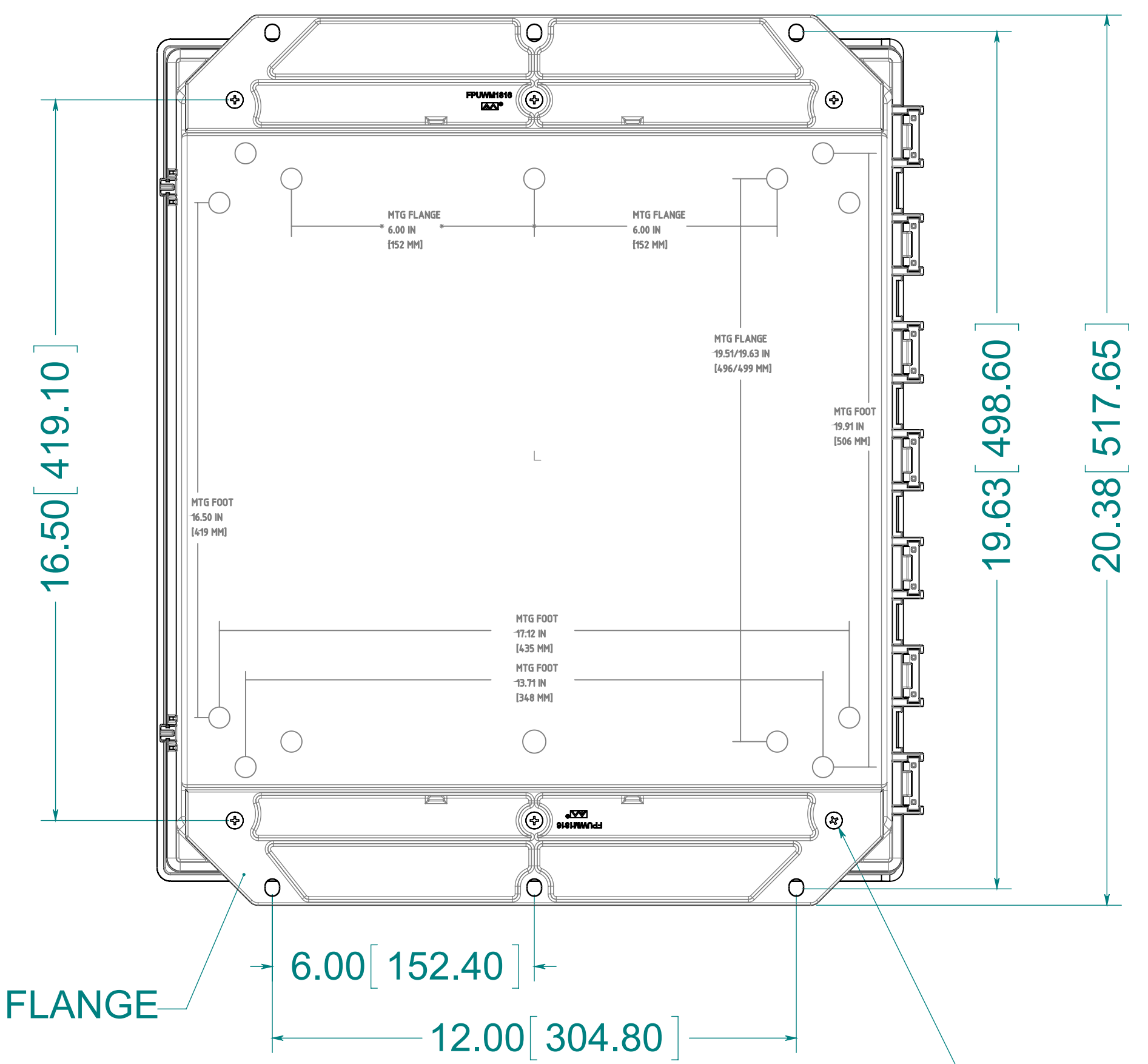

(4) POLYCARBONATE FLANGE

(6) EACH #10-32 BRASS INSERTS AND STAINLESS STEEL FLANGE AND FEET SCREWS

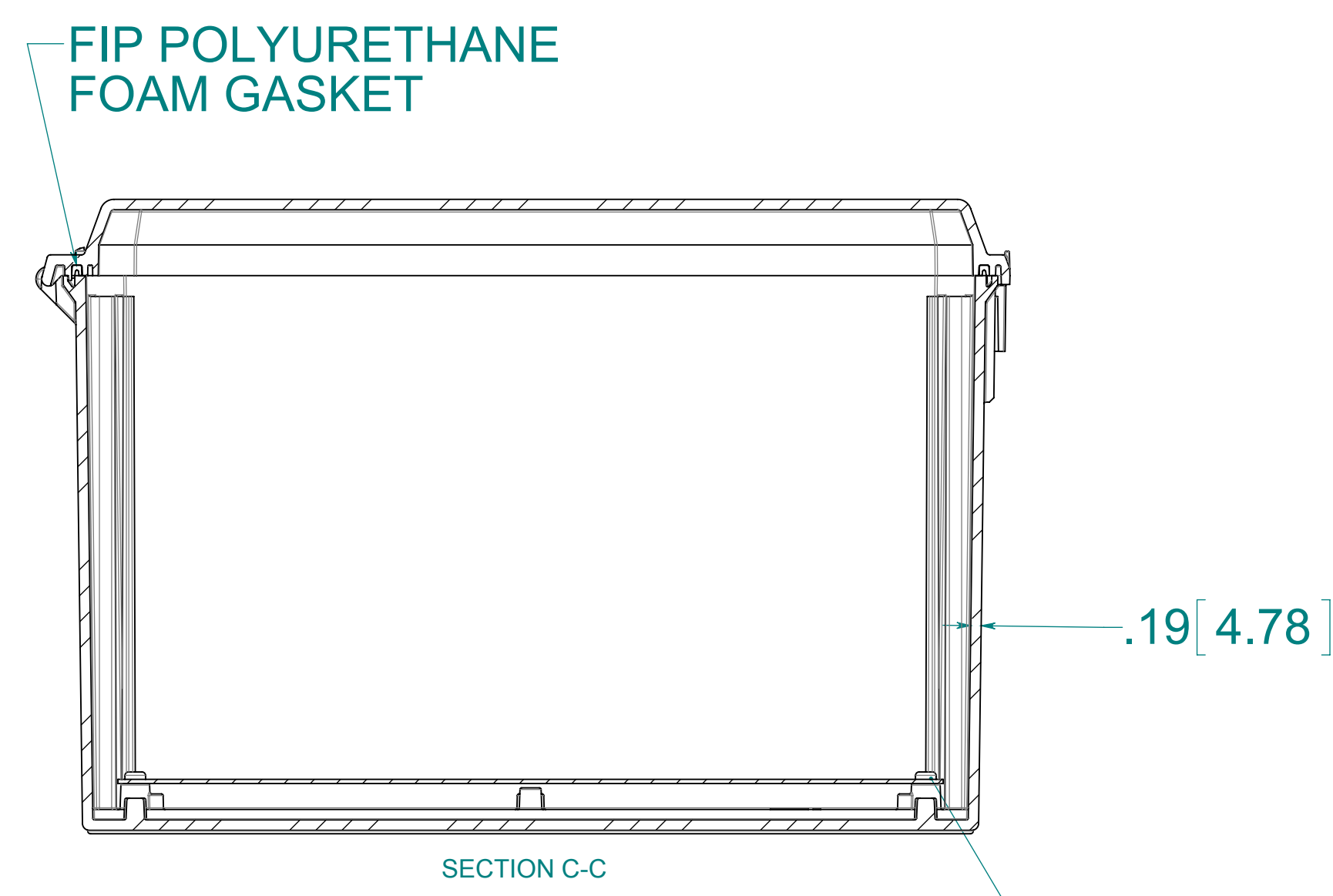

(4) EACH #10-32 BRASS INSERTS PLATED CARBON STEEL SCREWS TO RETAIN BACK PANEL

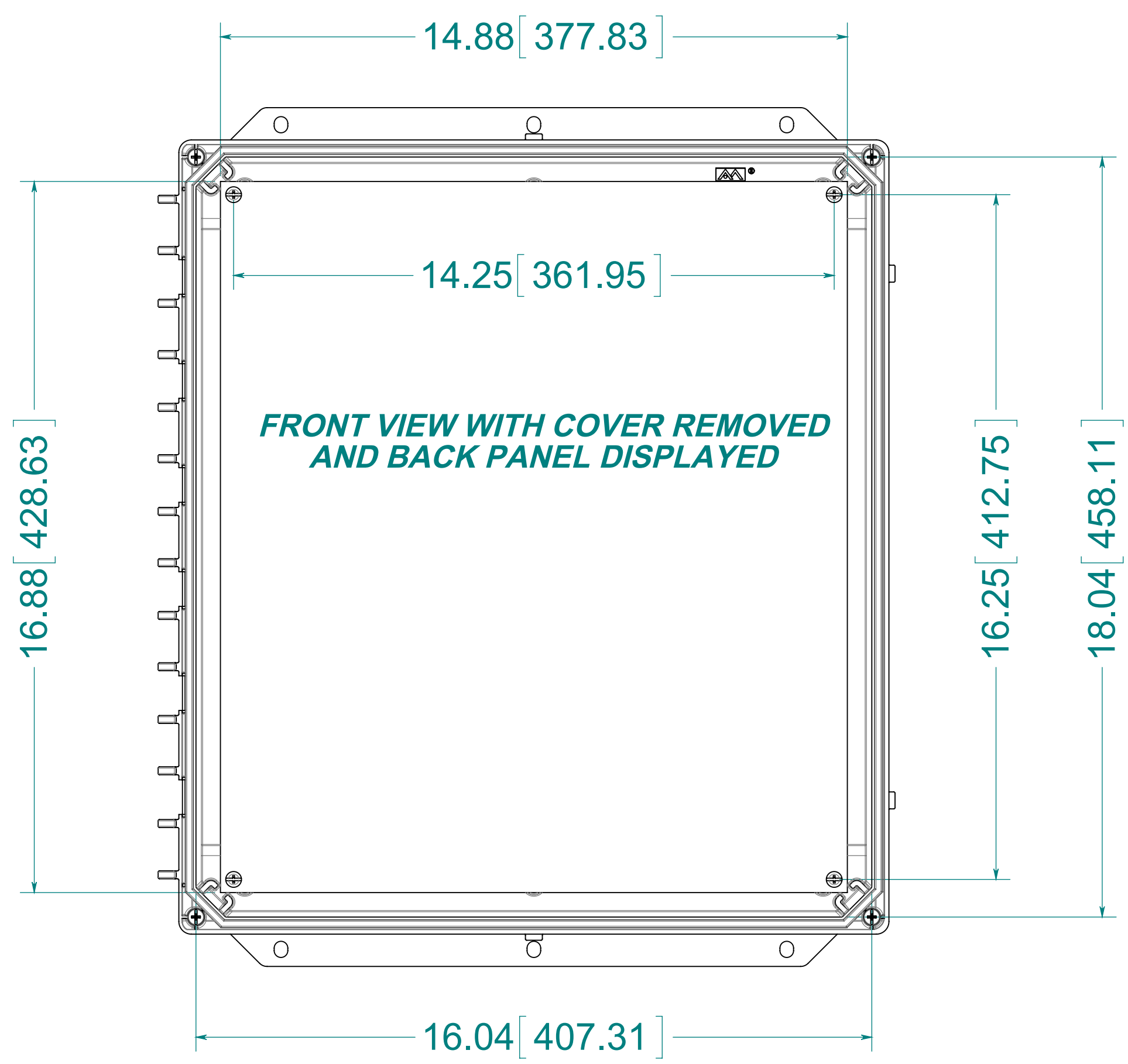

MATERIAL:  
 BOX: INJECTION MOLDED POLYCARBONATE  
 STANDARD COVER: INJECTION MOLDED POLYCARBONATE  
 CLEAR COVER: INJECTION MOLDED POLYCARBONATE

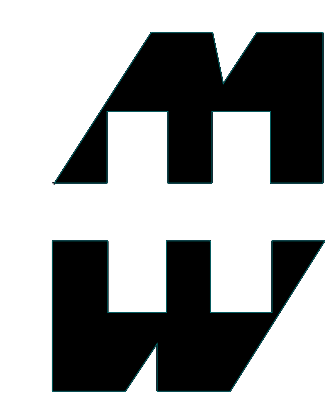

PART No. PCJ181610CCF

for more information visit [www.hammfg.com](http://www.hammfg.com)  
 Data subject to change without notice

Drawing Not to Scale