

Date	Rev	Description	ECN No.	DR	CK	REL
08/02/2019		INITIAL RELEASE	ECN-314	DJL	SRH	GEL
-	-	-	-	-	-	-
-	-	-	-	-	-	-

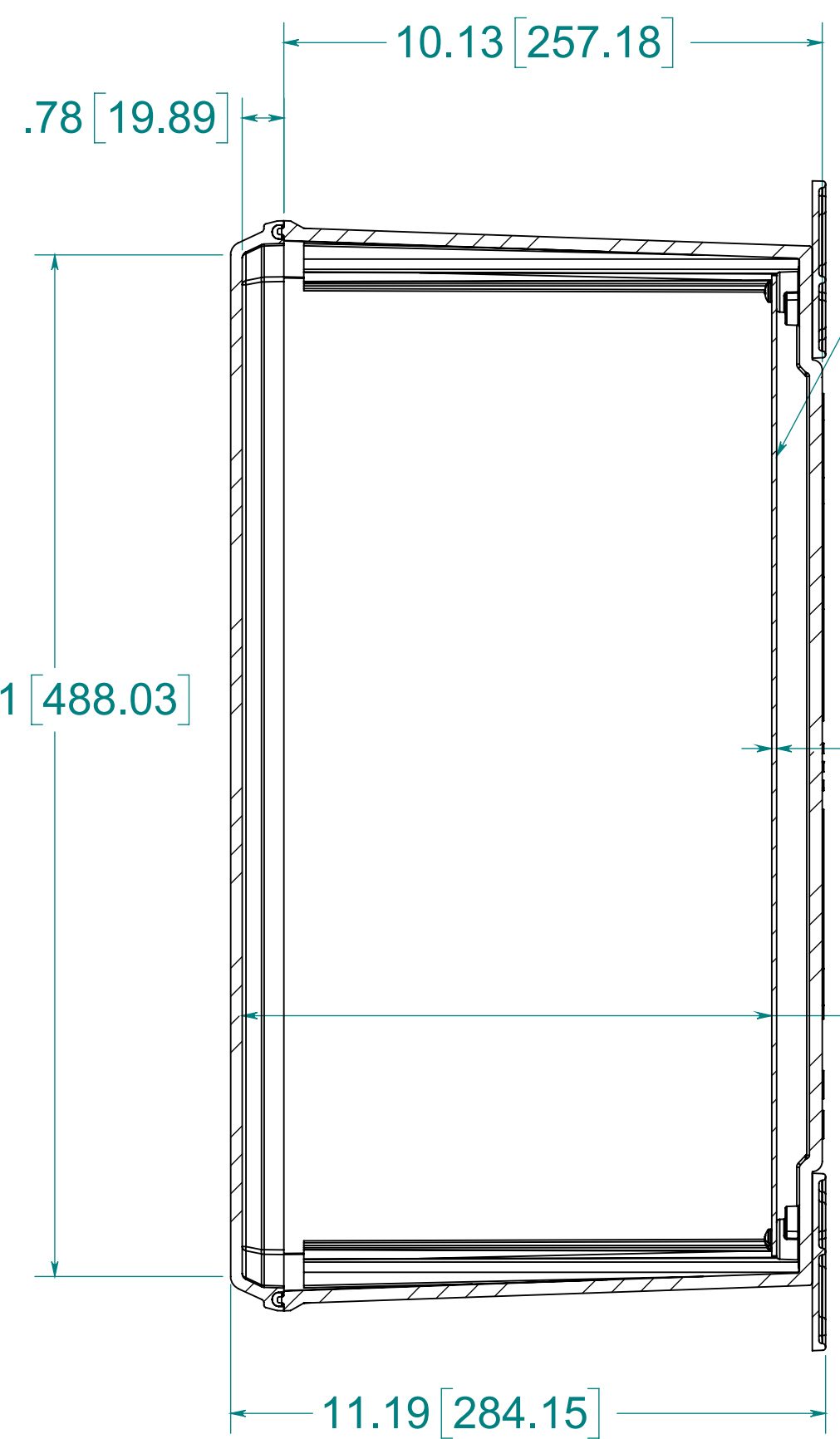

OPTIONAL BACK PANEL SHOWN  
 0.100 [2.54mm] TH'K- ALUMINUM  
 0.075 [1.91mm] TH'K- WHITE STEEL  
 0.188 [4.78mm] TH'K- PVC

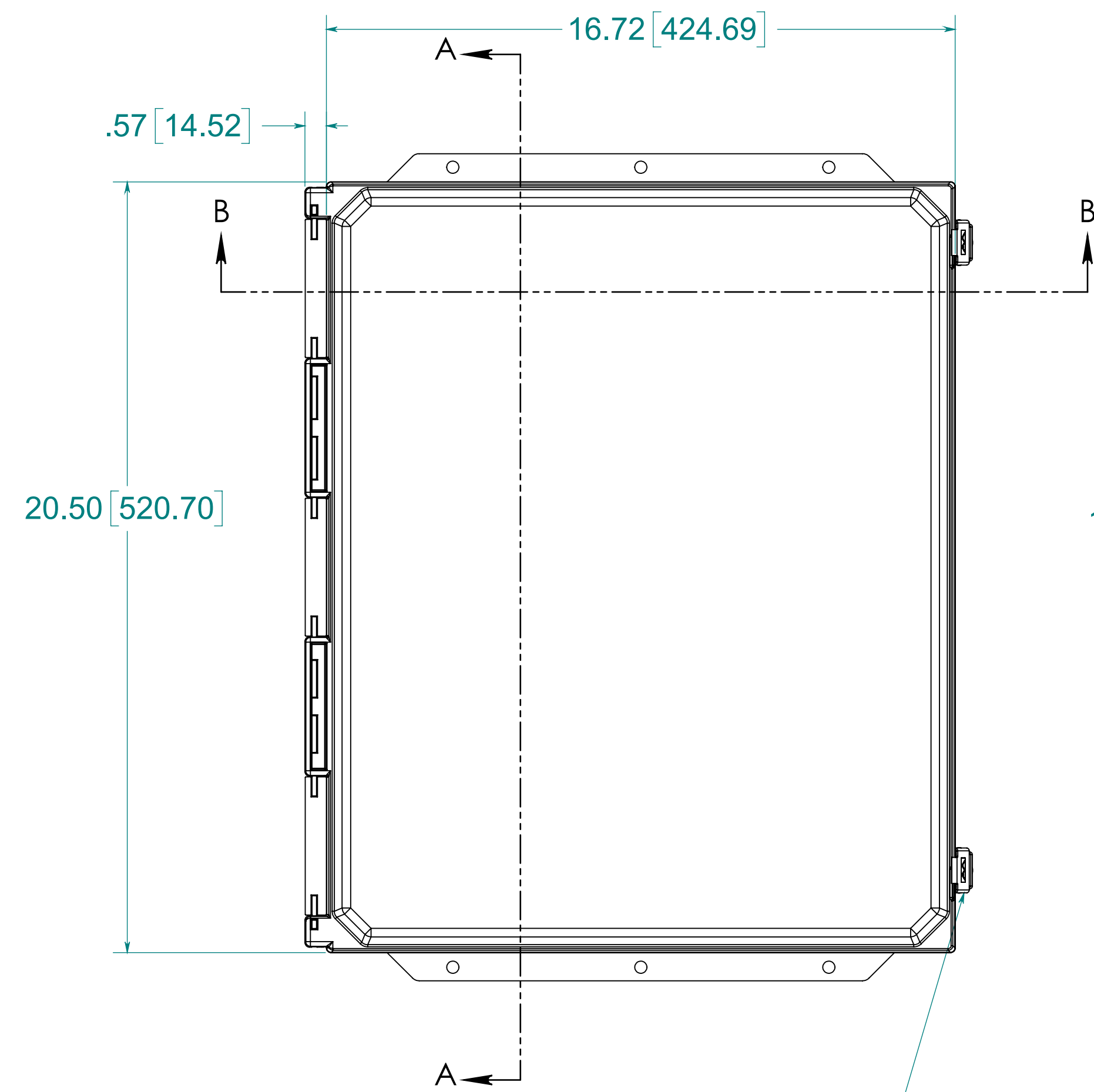
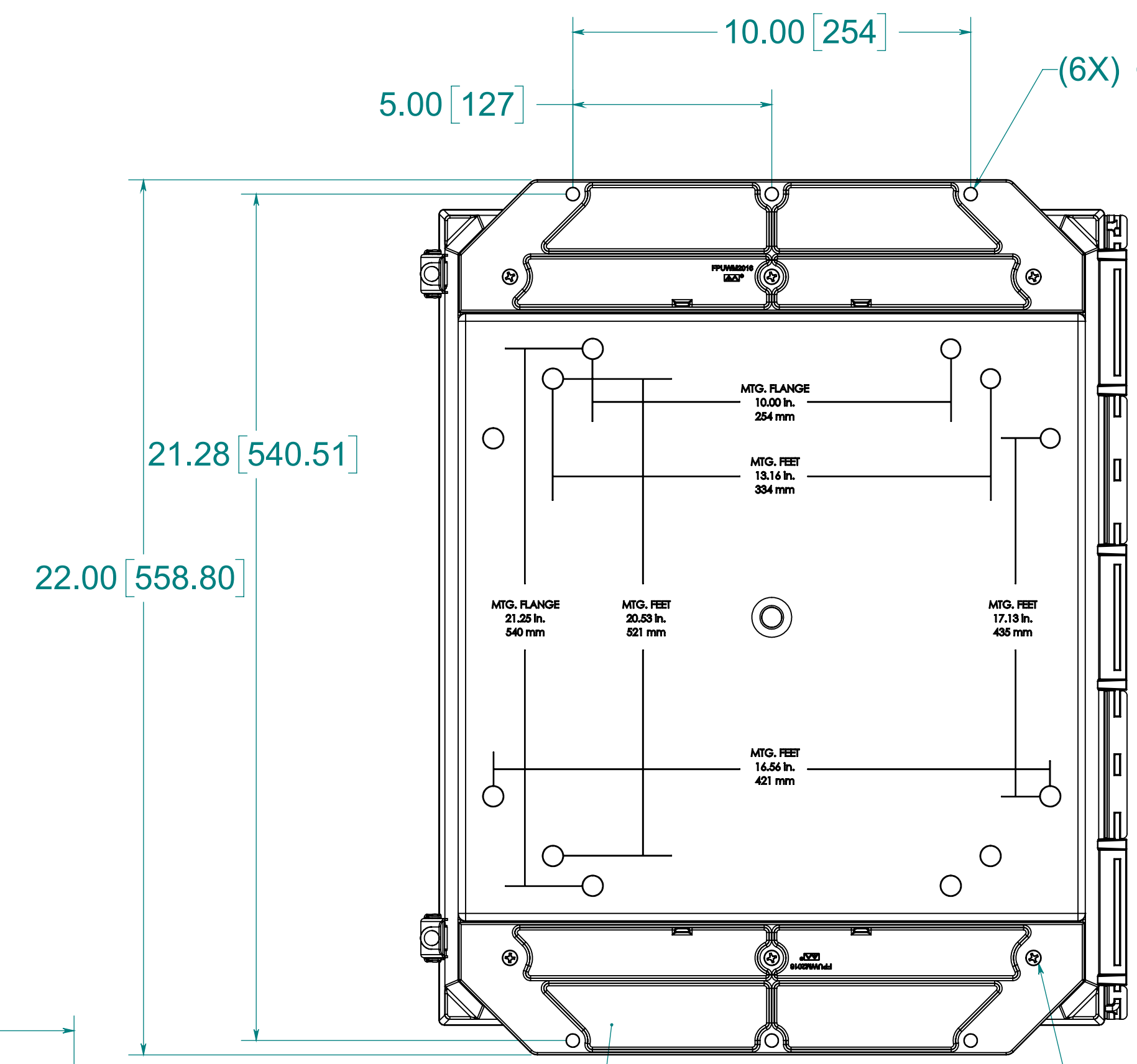

(2X) 316 STAINLESS STEEL  
 LOCKABLE SNAP LATCH

SECTION A-A

(2X) POLYCARBONATE  
 FLANGE  
 (6X) EACH #10-32 BRASS  
 INSERTS AND 316 STAINLESS  
 STEEL FLANGE SCREWS

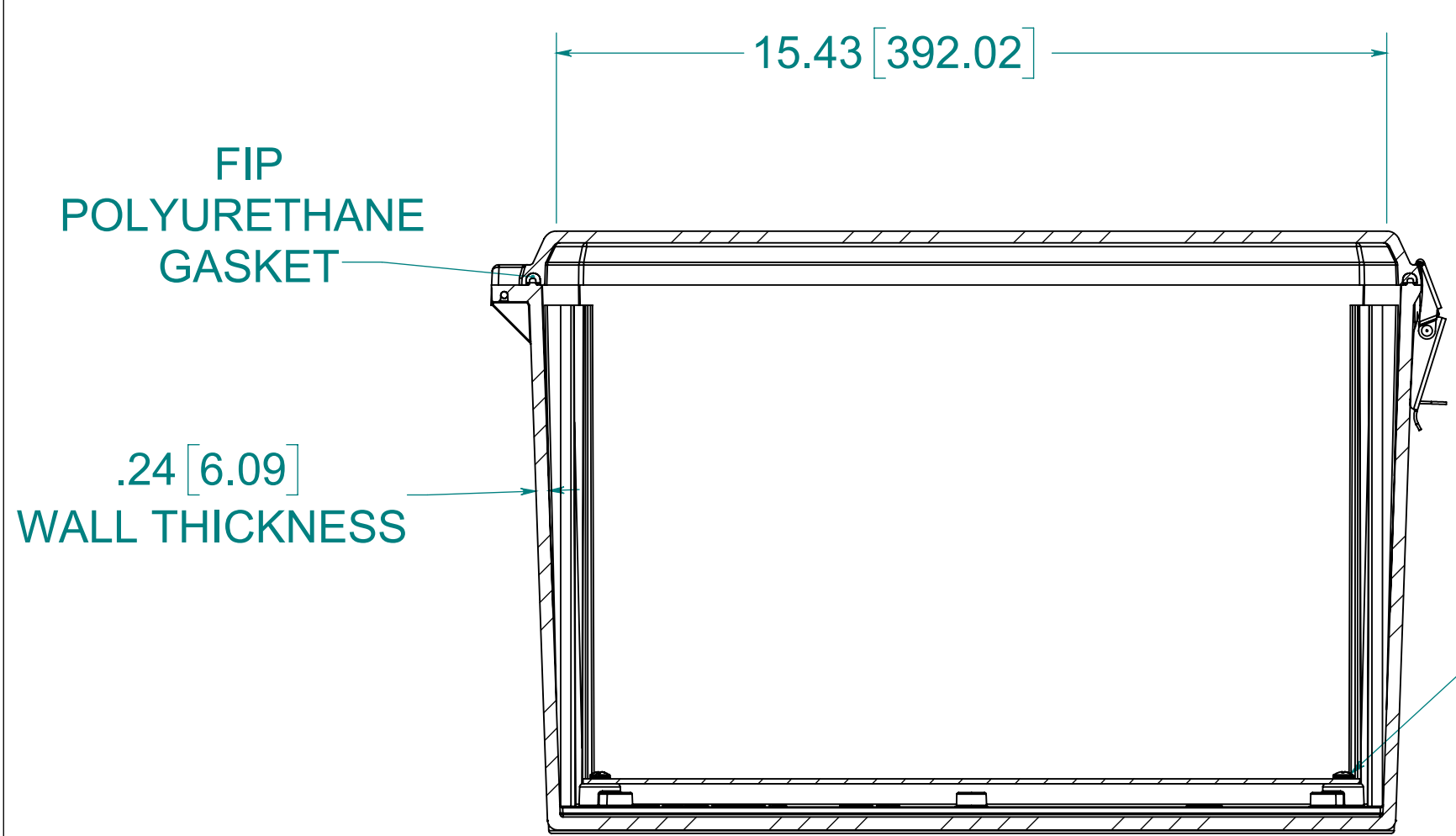

SECTION B-B

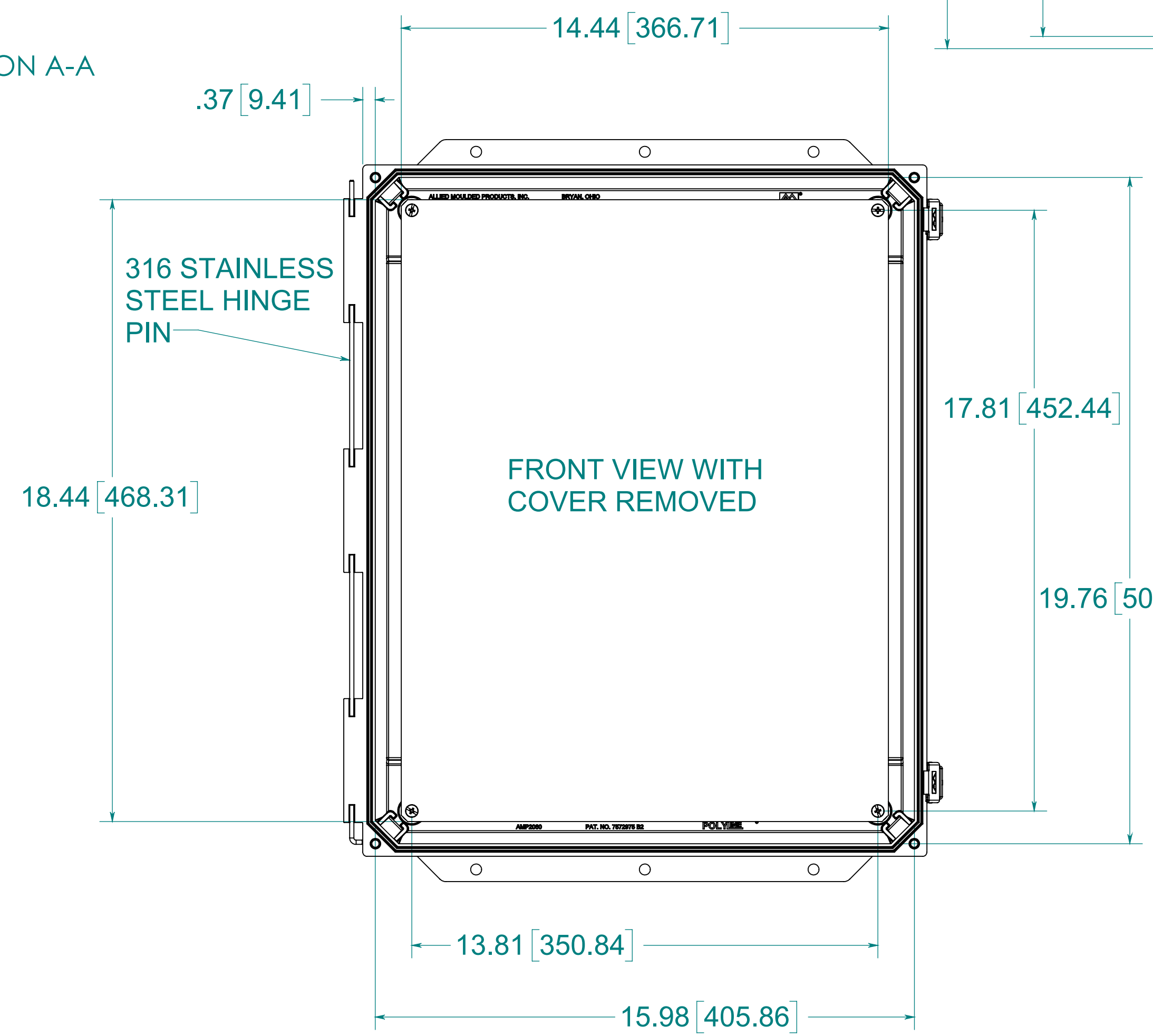

FRONT VIEW WITH  
 COVER REMOVED

NOTE:  
 1. DATA SUBJECT TO CHANGE  
 WITHOUT NOTICE.

MATERIAL:  
 BOX- INJECTED POLYCARBONATE  
 STANDARD COVER- INJECTED POLYCARBONATE  
 CLEAR COVER- INJECTED POLYCARBONATE

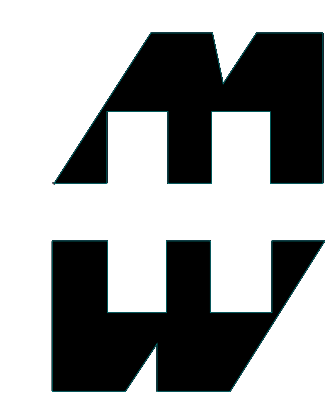

PART No. PCJ201610CCLF

for more information visit  
[www.hammfg.com](http://www.hammfg.com)  
 Data subject to change without notice  
 Drawing Not to Scale