

Date	Rev	Description	ECN No.	DR	CK	REL
08/02/2019		INITIAL RELEASE	ECN-314	DJL	SRH	GEL
-	-	-	-	-	-	-
-	-	-	-	-	-	-

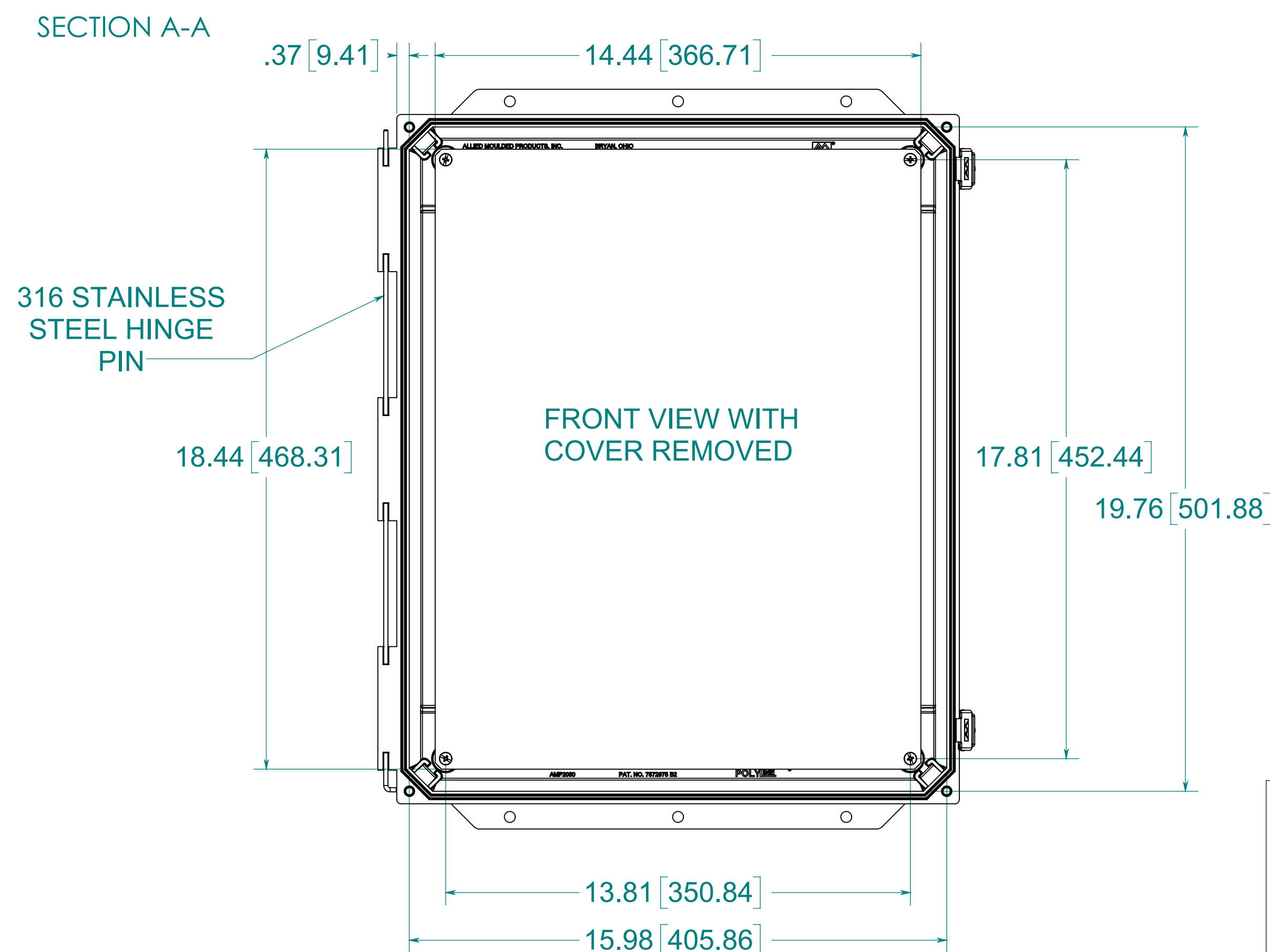

NOTE:  
1. DATA SUBJECT TO CHANGE WITHOUT NOTICE

MATERIAL:  
BOX- INJECTED POLYCARBONATE  
STANDARD COVER- INJECTED POLYCARBONATE  
CLEAR COVER- INJECTED POLYCARBONATE

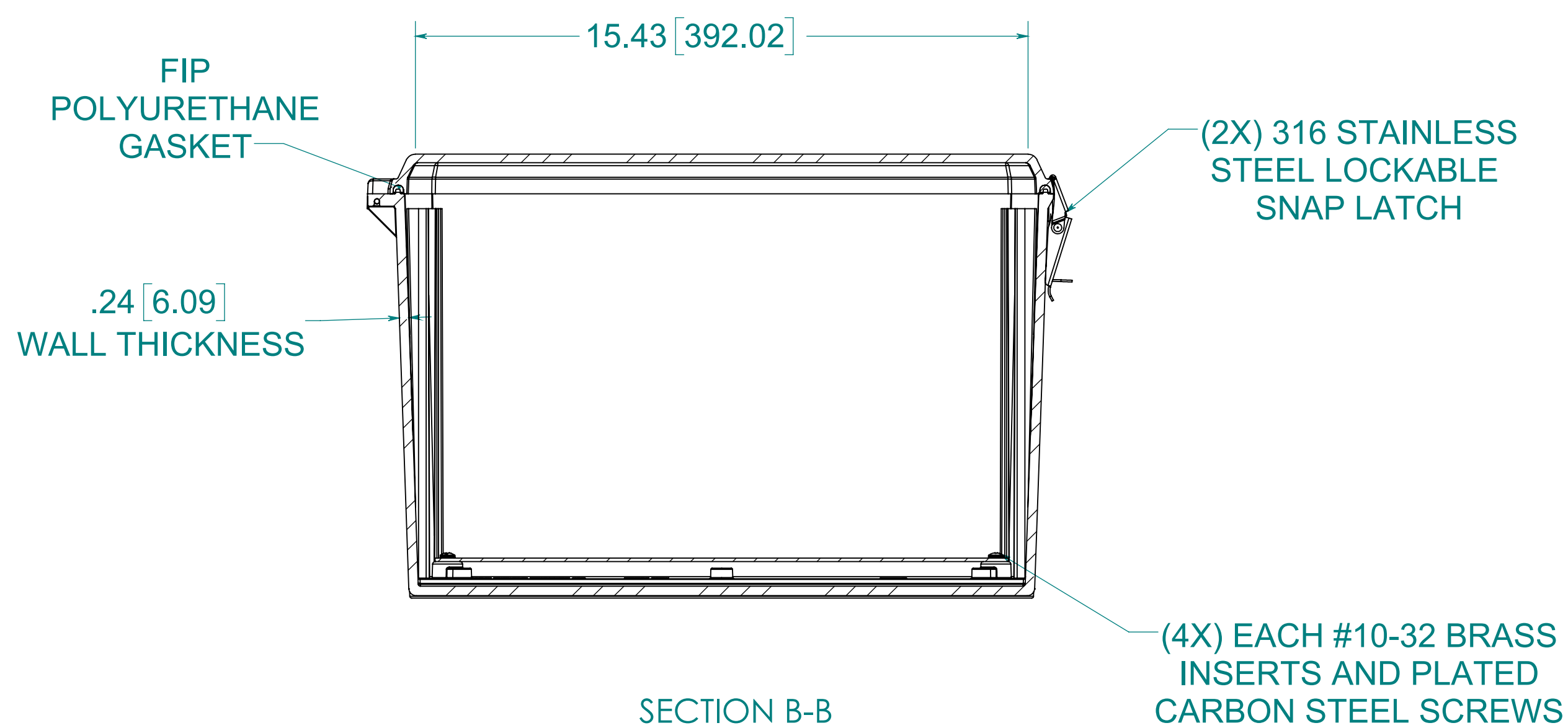
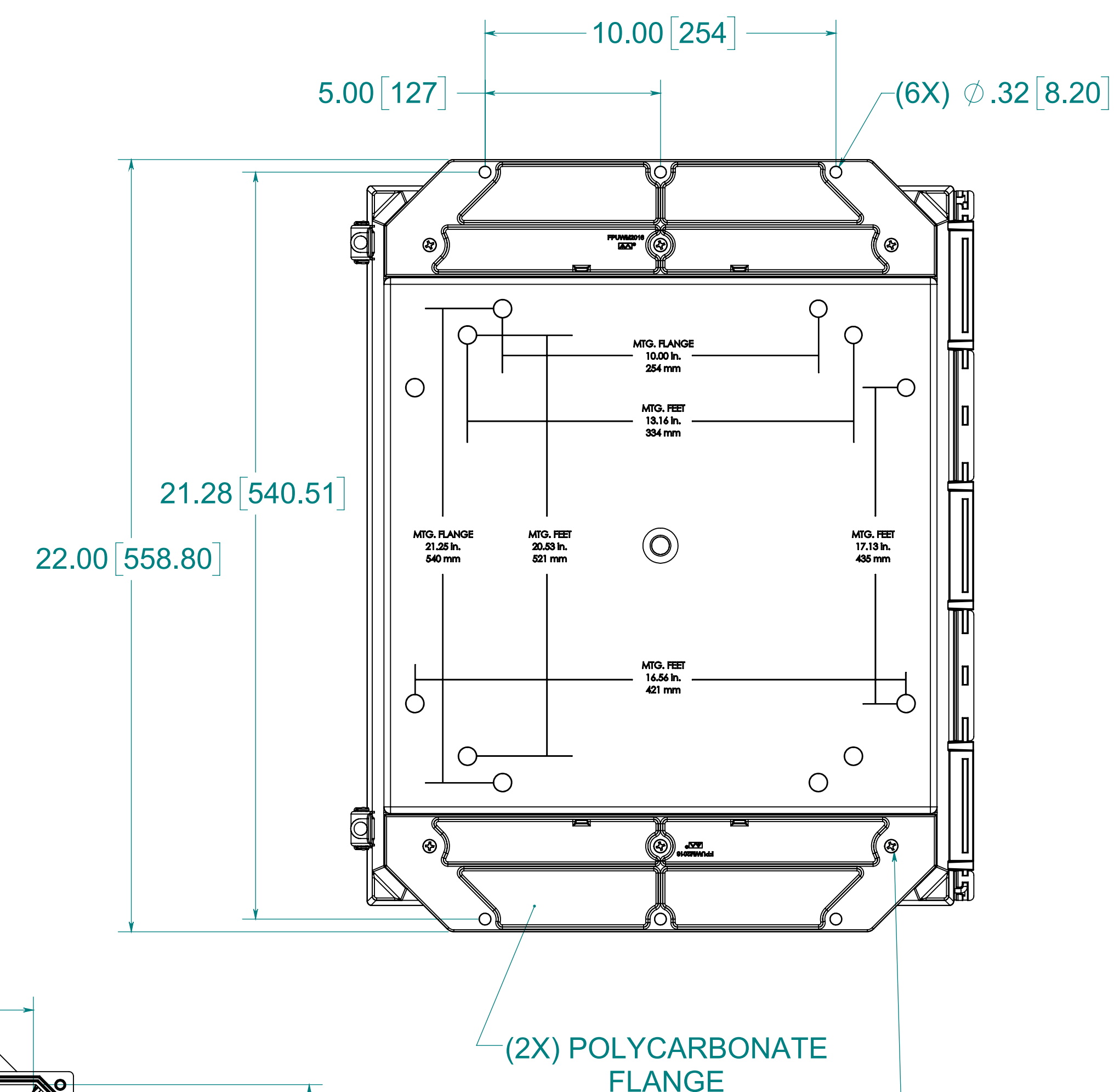
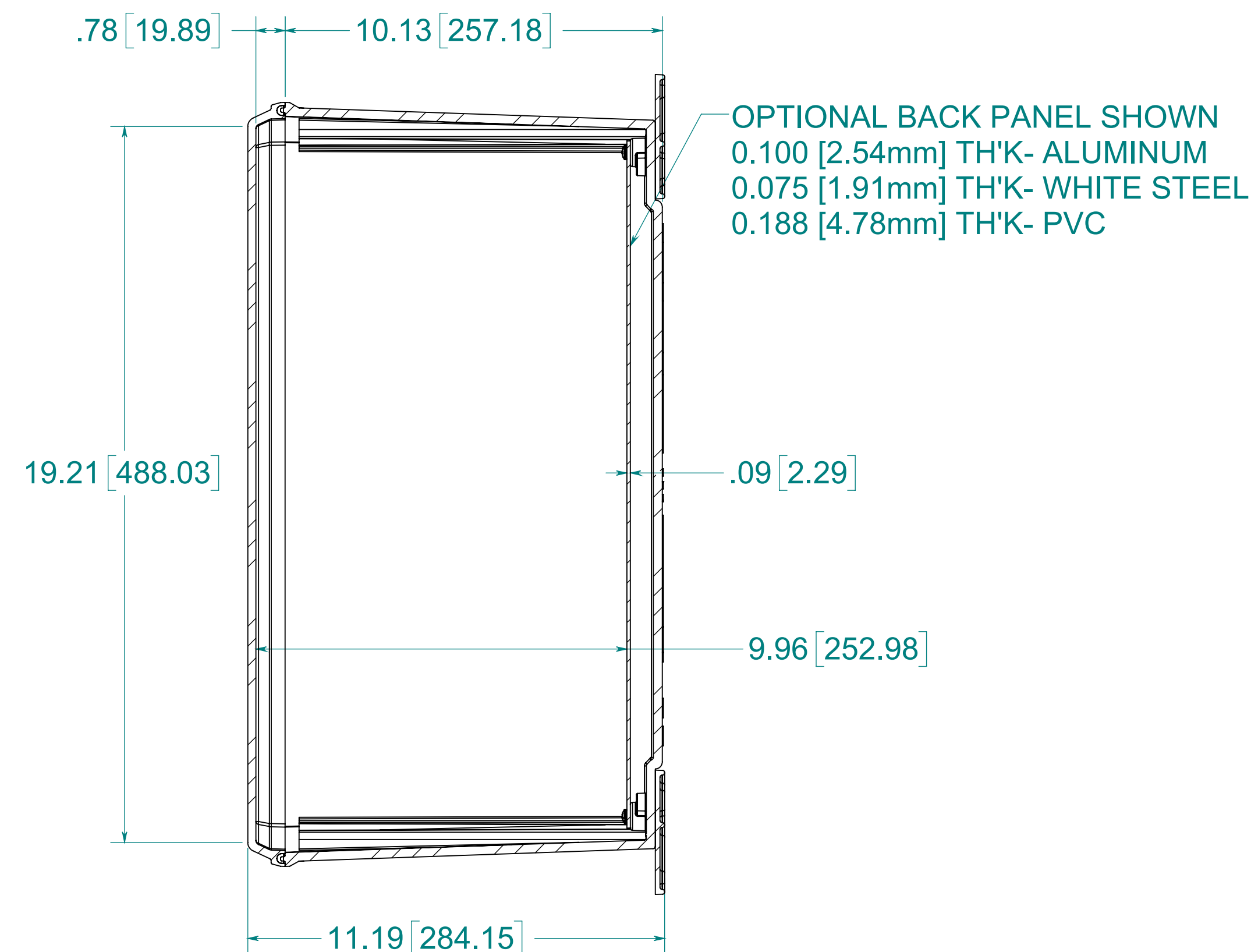
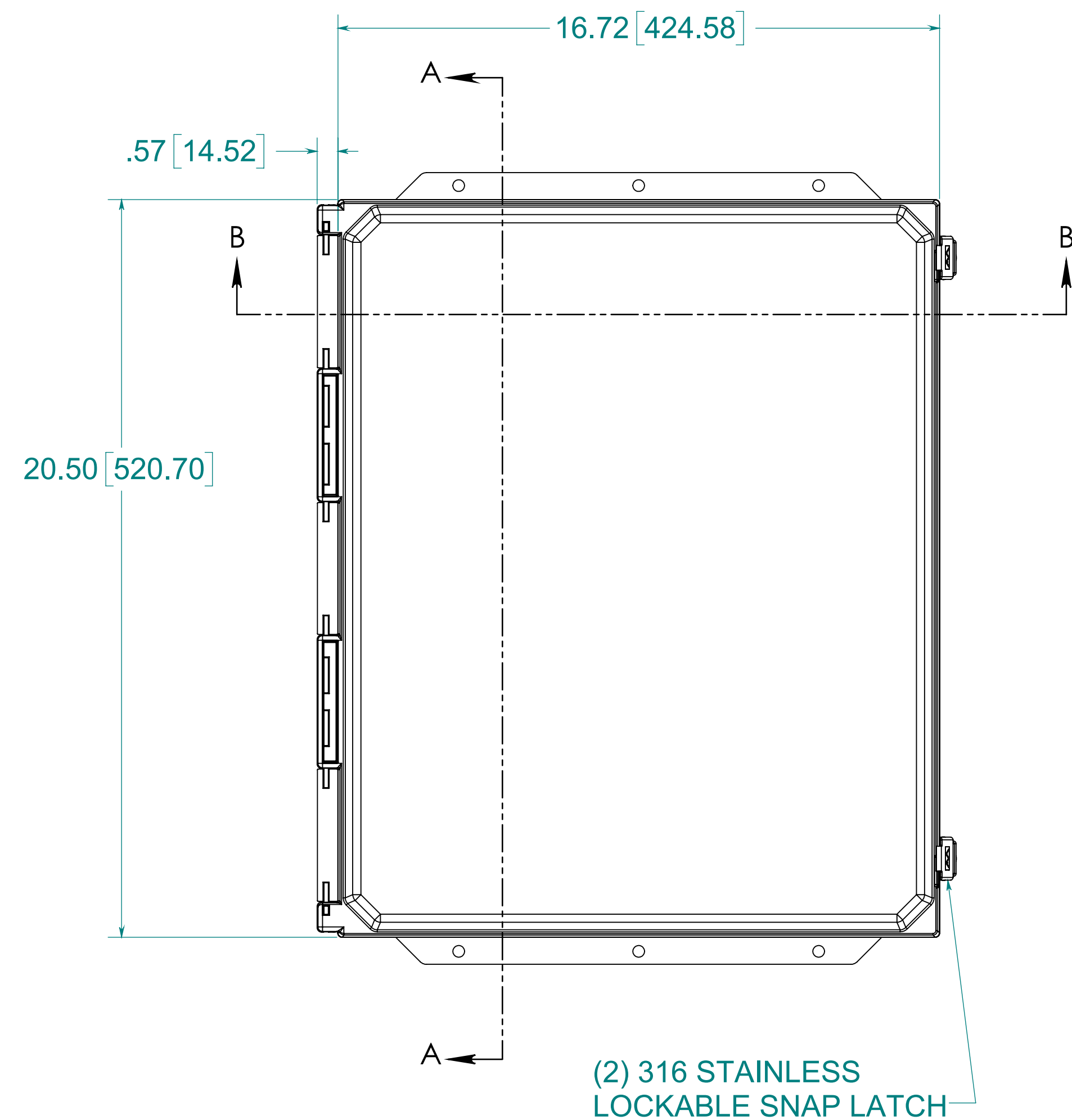
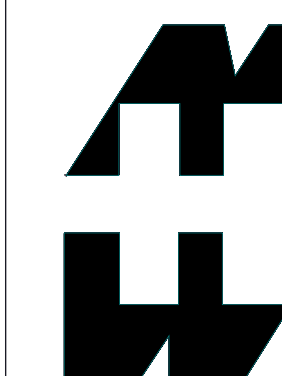

PART No. PCJ201610LF

for more information visit  
[www.hammfg.com](http://www.hammfg.com)  
Data subject to change without notice  
Drawing Not to Scale