

(4) EACH #10-32 BRASS INSERTS AND 316 STAINLESS STEEL CAPTIVE COVER SCREWS

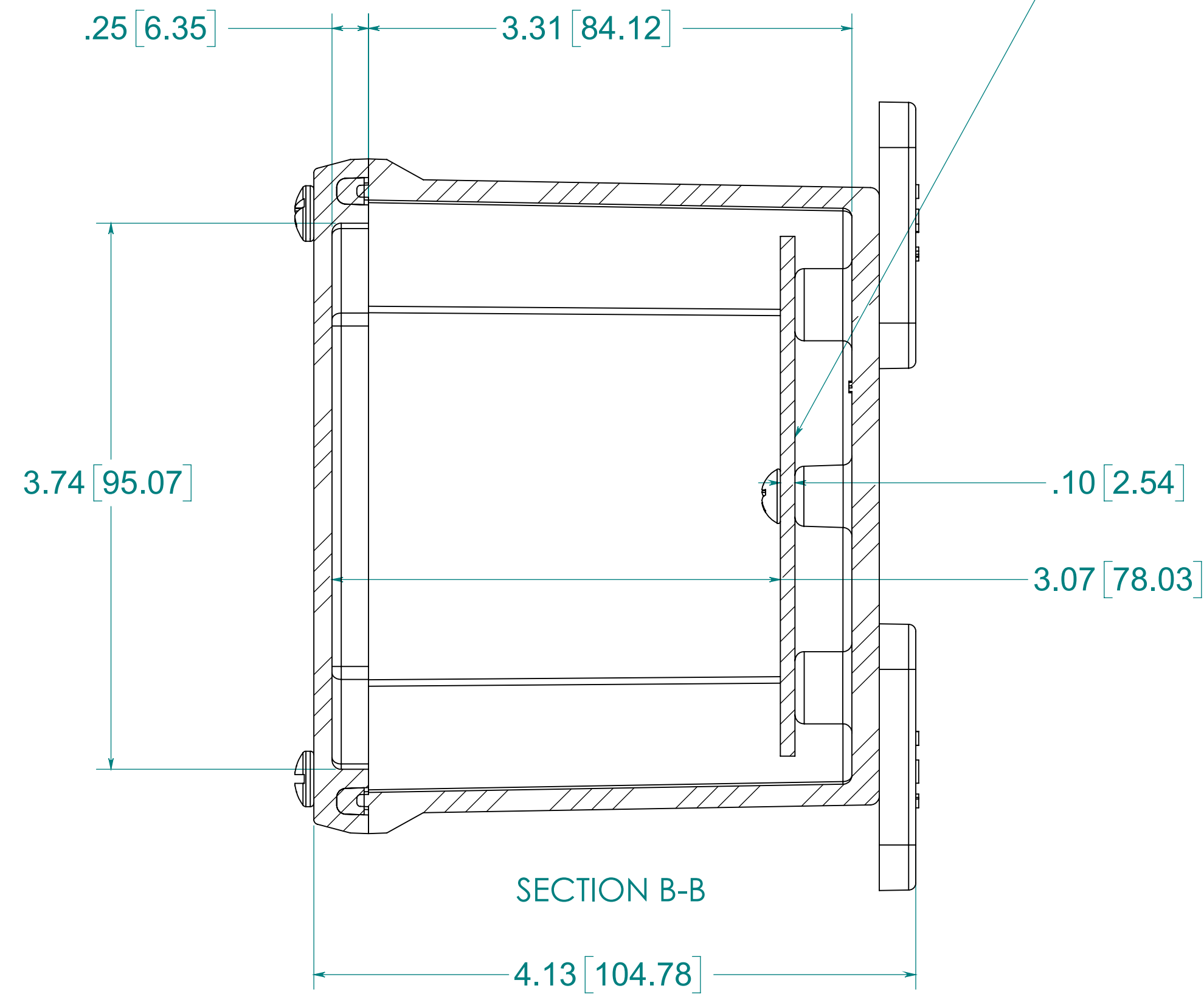

OPTIONAL BACK PANEL SHOWN
 0.100 [2.54mm] TH'K-ALUMINUM
 0.075 [1.91mm] TH'K-WHITE STEEL
 0.188 [4.78mm] TH'K-PVC

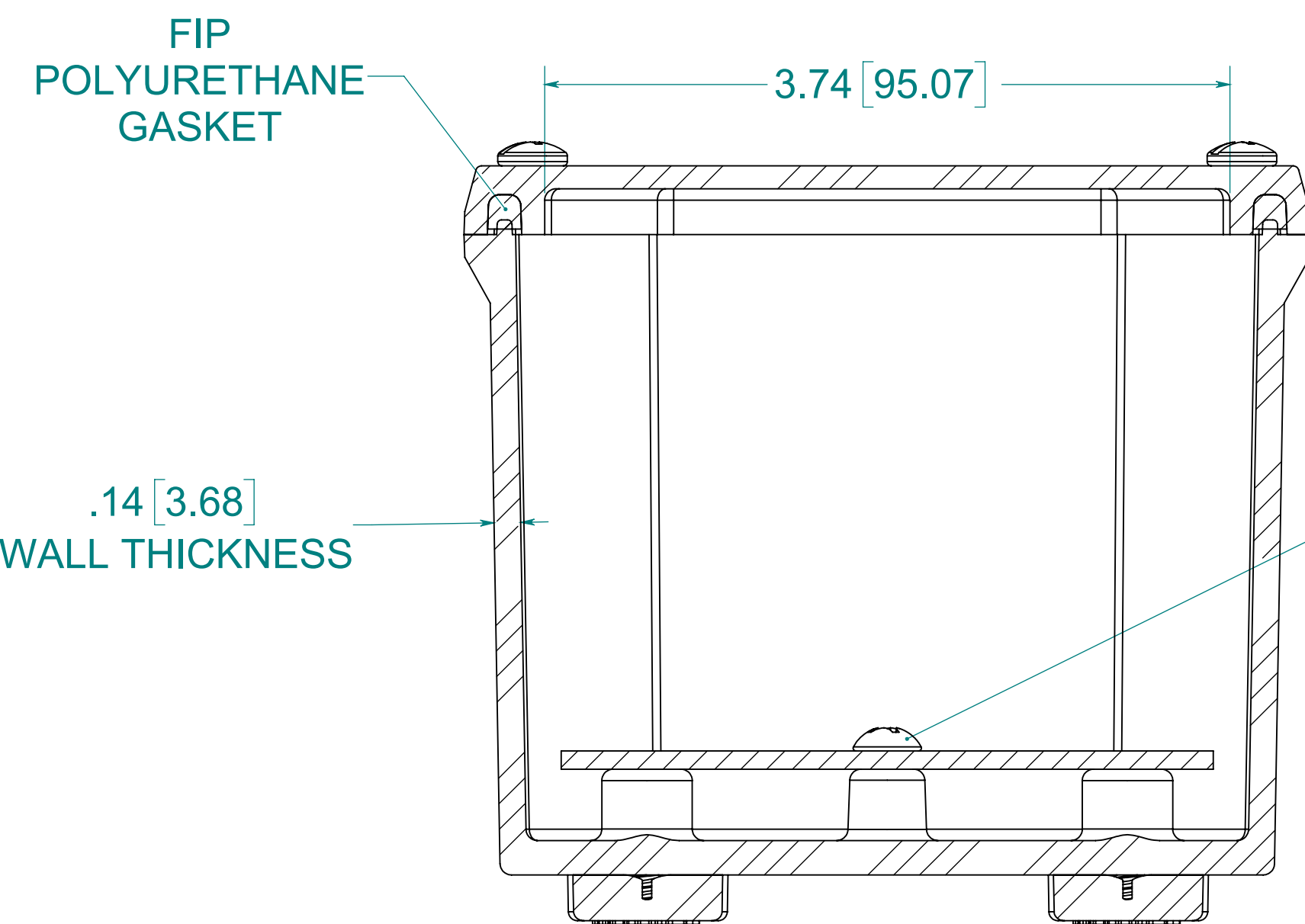
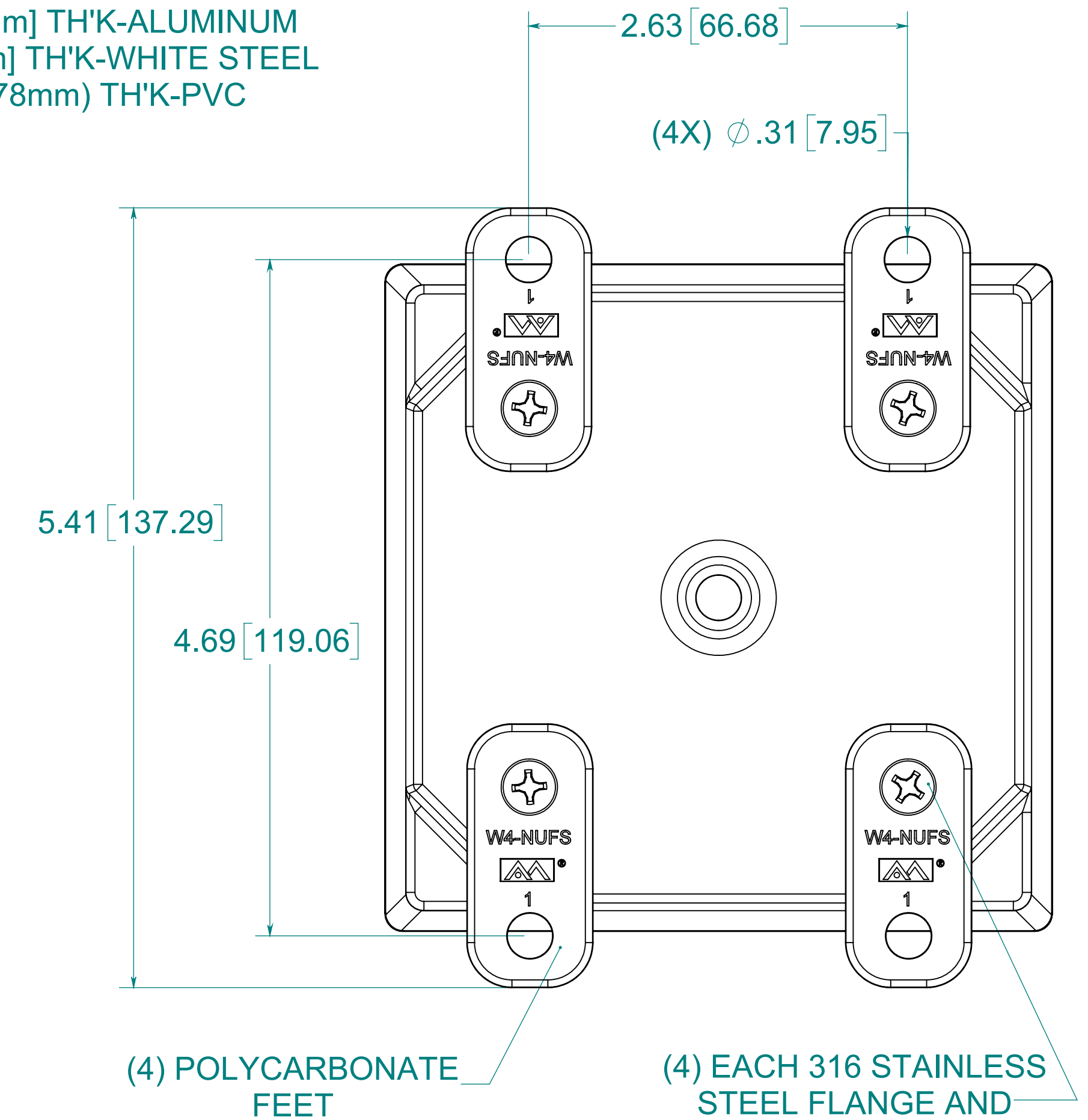

SECTION A-A

(4) EACH 316 STAINLESS STEEL PANEL SCREWS

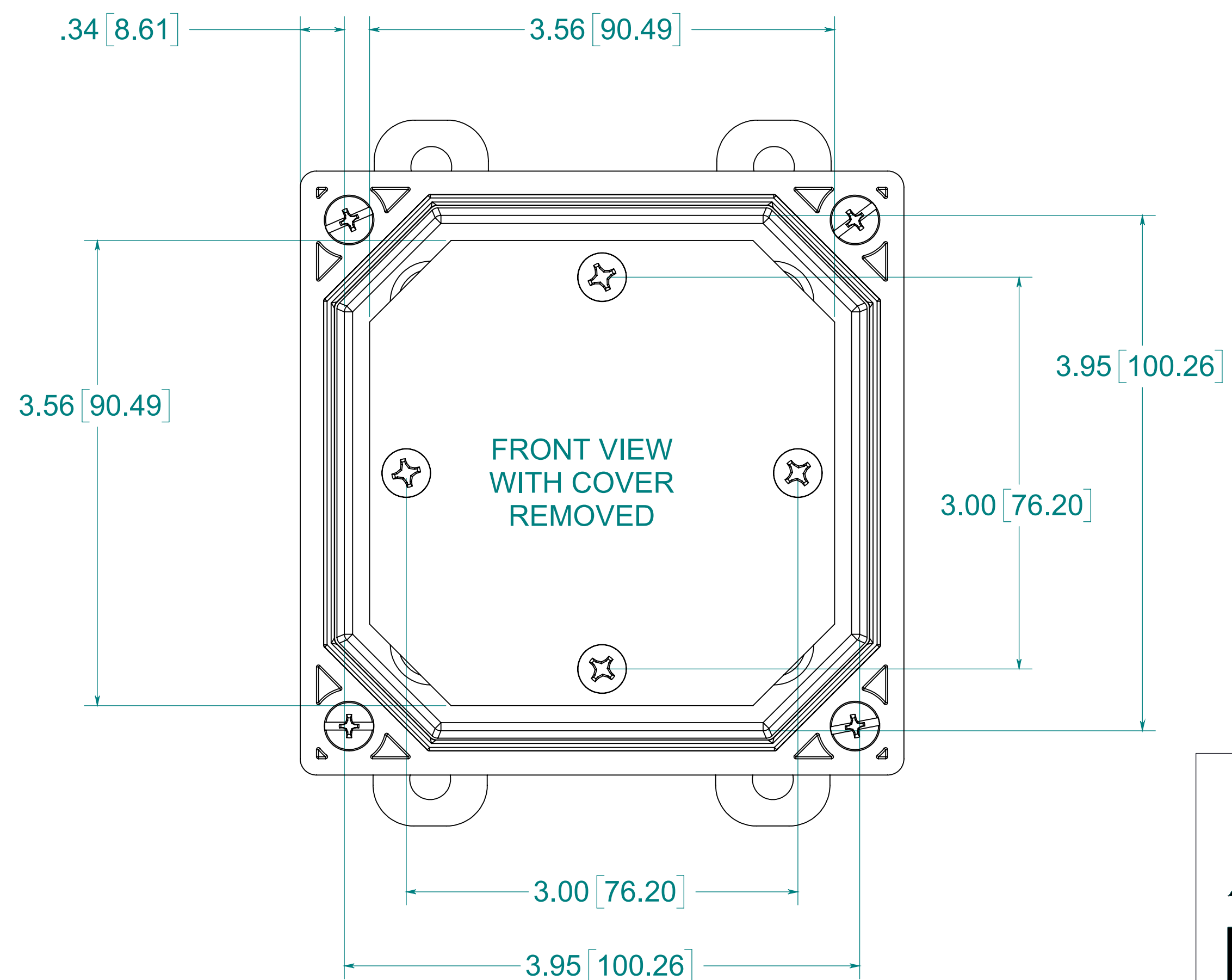

NOTE:
 1. DATA SUBJECT TO CHANGE WITHOUT NOTICE

MATERIAL:
 BOX - INJECTED POLYCARBONATE
 STANDARD COVER - INJECTED POLYCARBONATE
 CLEAR COVER - INJECTED POLYCARBONATE

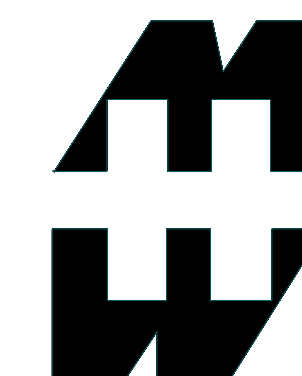

PART No. PCJ443.WEB

for more information visit
www.hammfg.com
 Data subject to change without notice

Drawing Not to Scale