

Date	Rev	Description	ECN No.	DR	CK	REL
04/11/2018		INITIAL RELEASE	ECN-12365	SMZ	ZDW	GEL
-	-	-	-	-	-	-
-	-	-	-	-	-	-

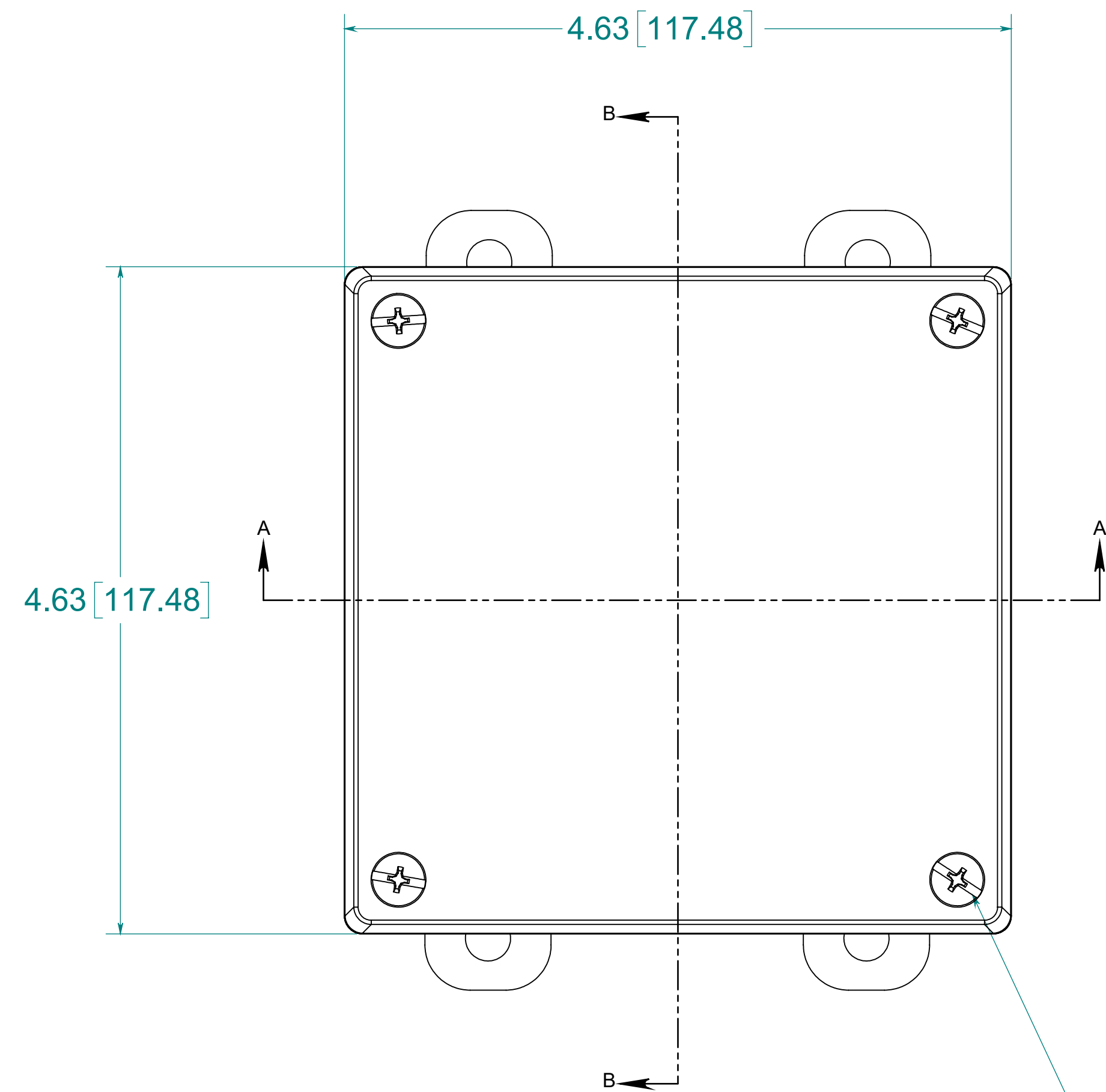

(4) EACH #10-32 BRASS INSERTS AND 316 STAINLESS STEEL CAPTIVE COVER SCREWS

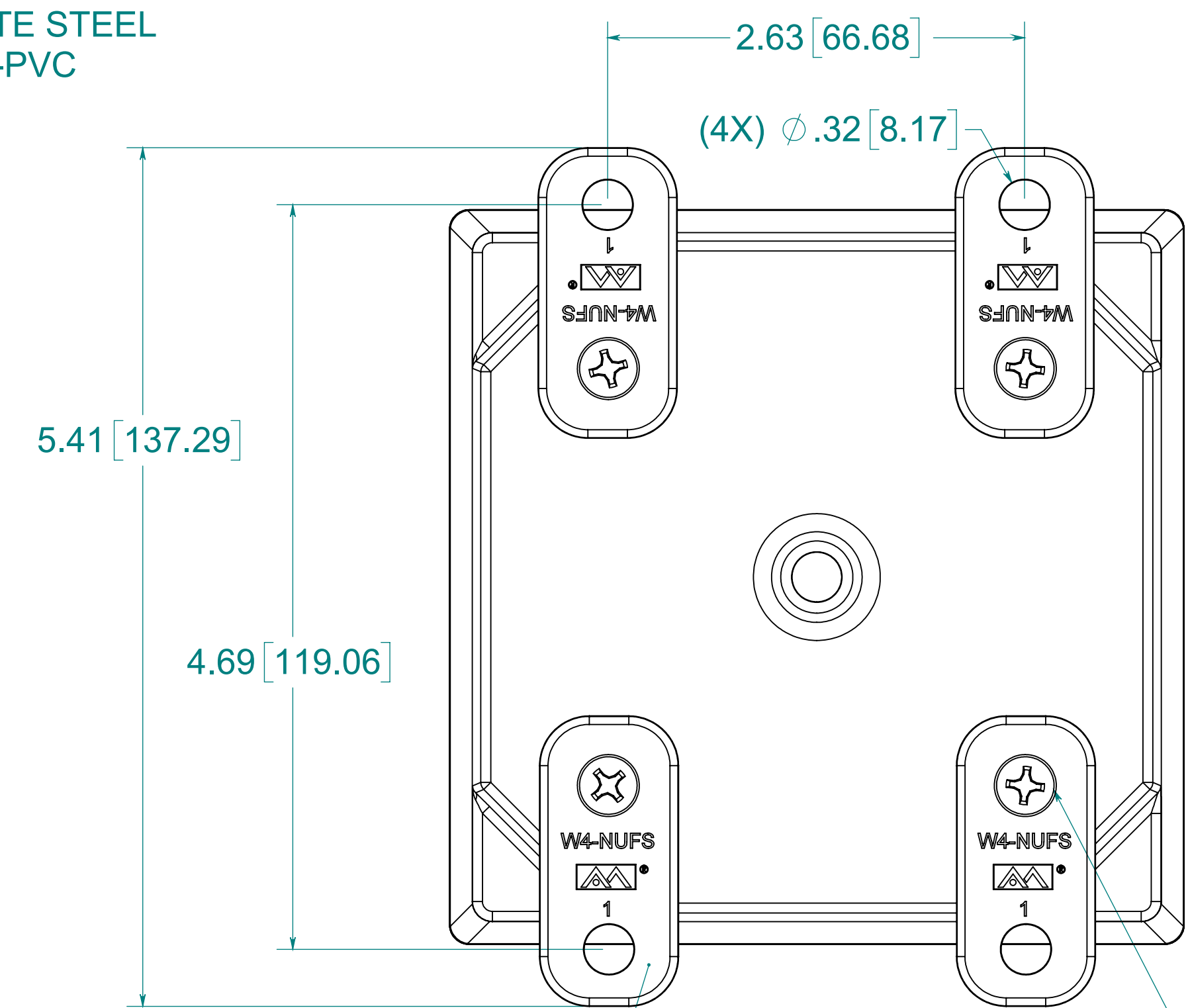
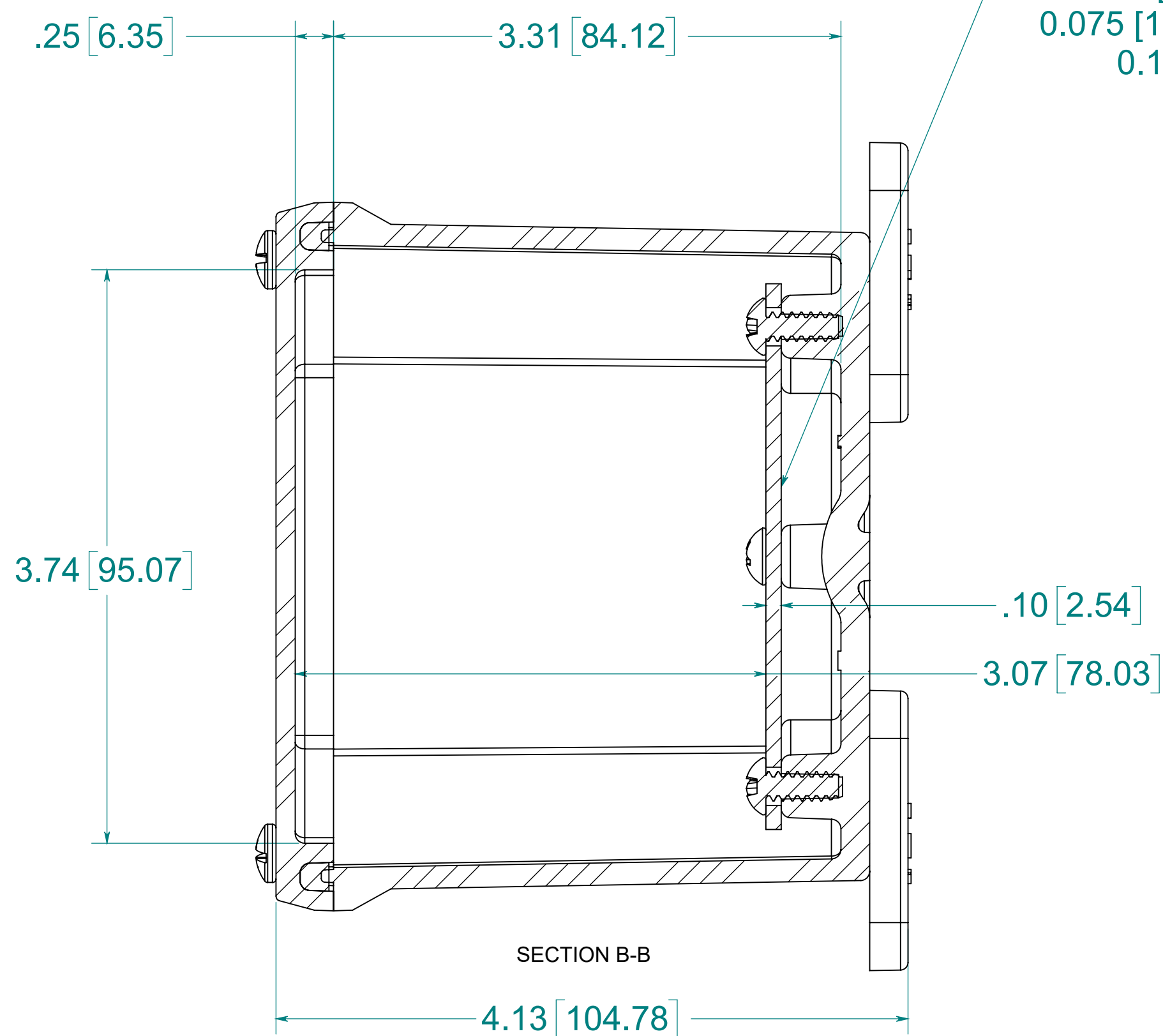

(4) POLYCARBONATE FEET

(4) EACH 316 STAINLESS STEEL FLANGE AND FEET SCREWS

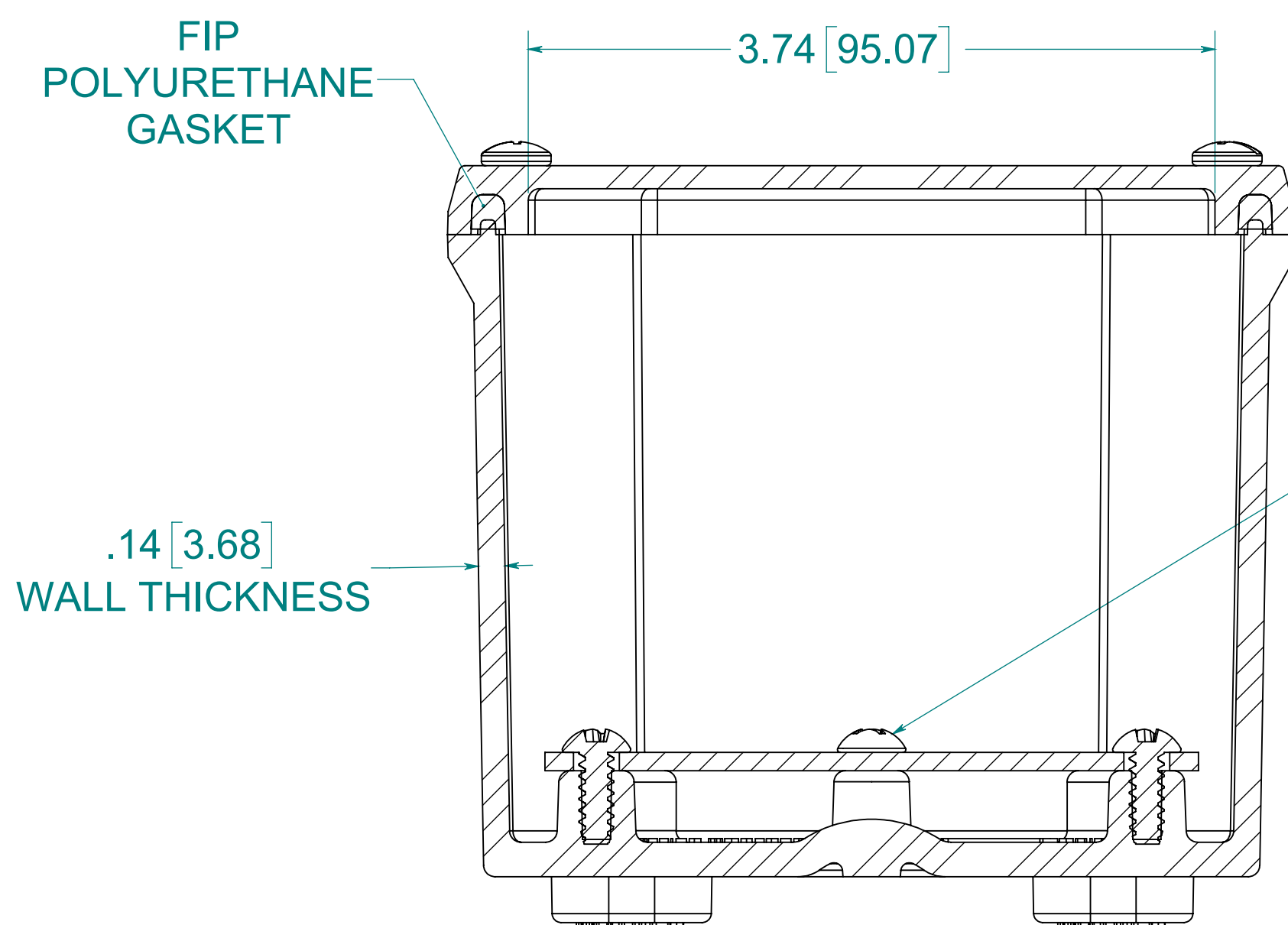

(4) EACH 316 STAINLESS STEEL PANEL SCREWS

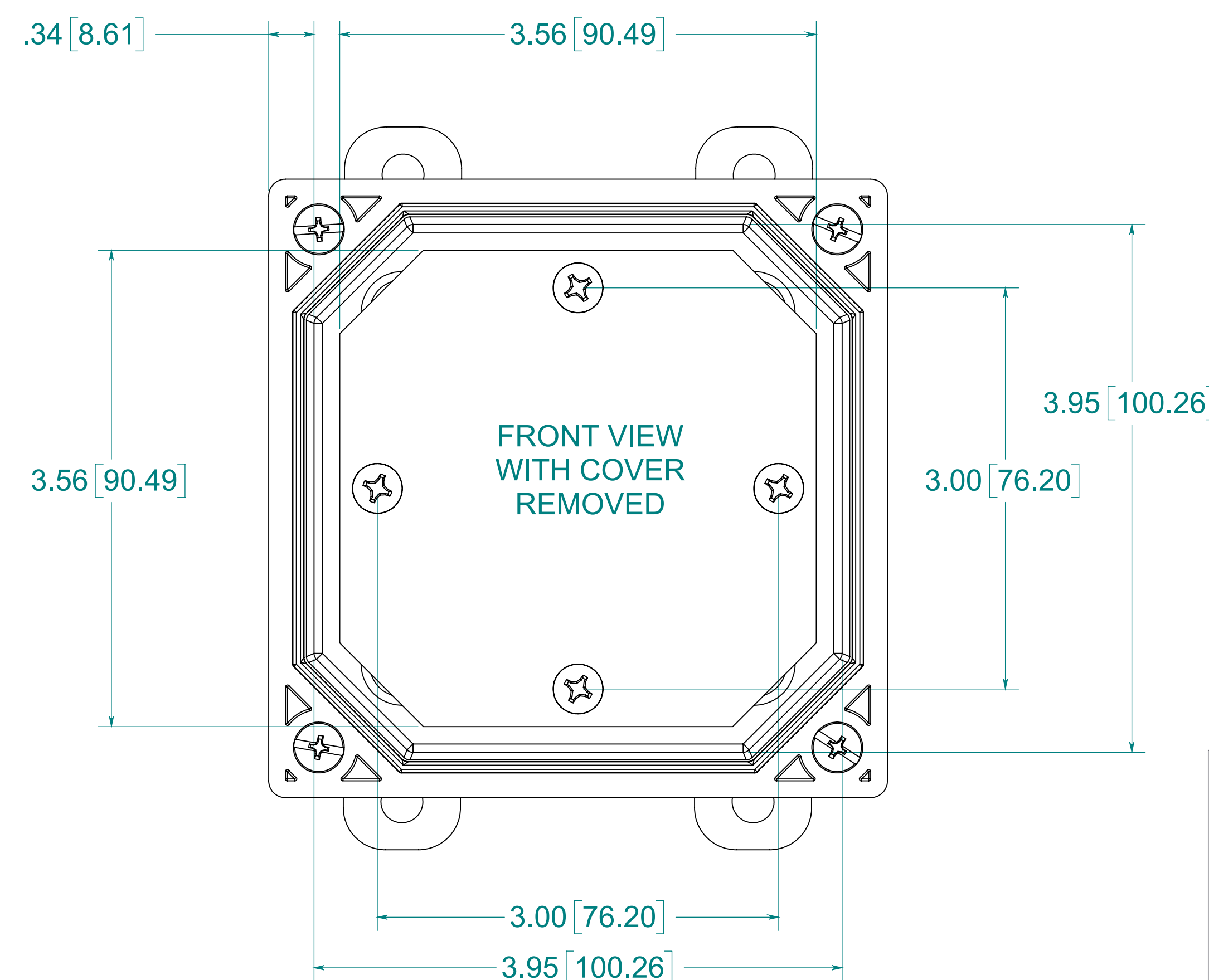

NOTE:  
 1. DATA SUBJECT TO CHANGE WITHOUT NOTICE

MATERIAL:  
 BOX - INJECTED POLYCARBONATE  
 STANDARD COVER - INJECTED POLYCARBONATE  
 CLEAR COVER - INJECTED POLYCARBONATE

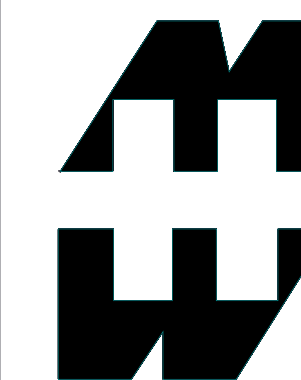

PART No. PCJ443CC.WEB

for more information visit  
[www.hammfg.com](http://www.hammfg.com)  
 Data subject to change without notice  
 Drawing Not to Scale