

(4) EACH #10-32 BRASS INSERTS AND 316 STAINLESS STEEL CAPTIVE COVER SCREWS

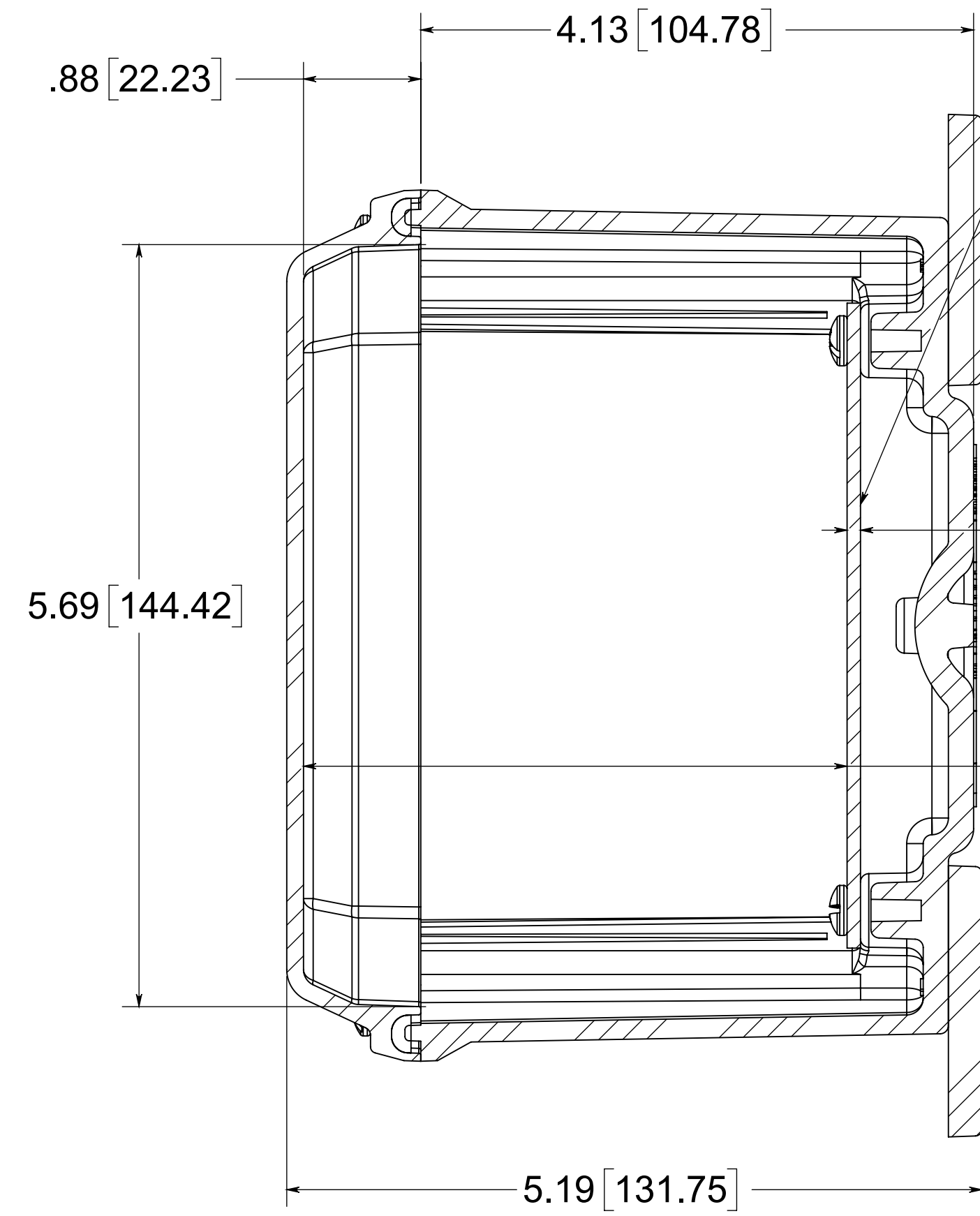

SECTION B-B

OPTIONAL BACK PANEL SHOWN  
 0.100 [2.54mm] TH'K- ALUMINUM  
 0.075 [1.91mm] TH'K- WHITE STEEL  
 0.125 [3.18mm] TH'K - FIBERGLASS

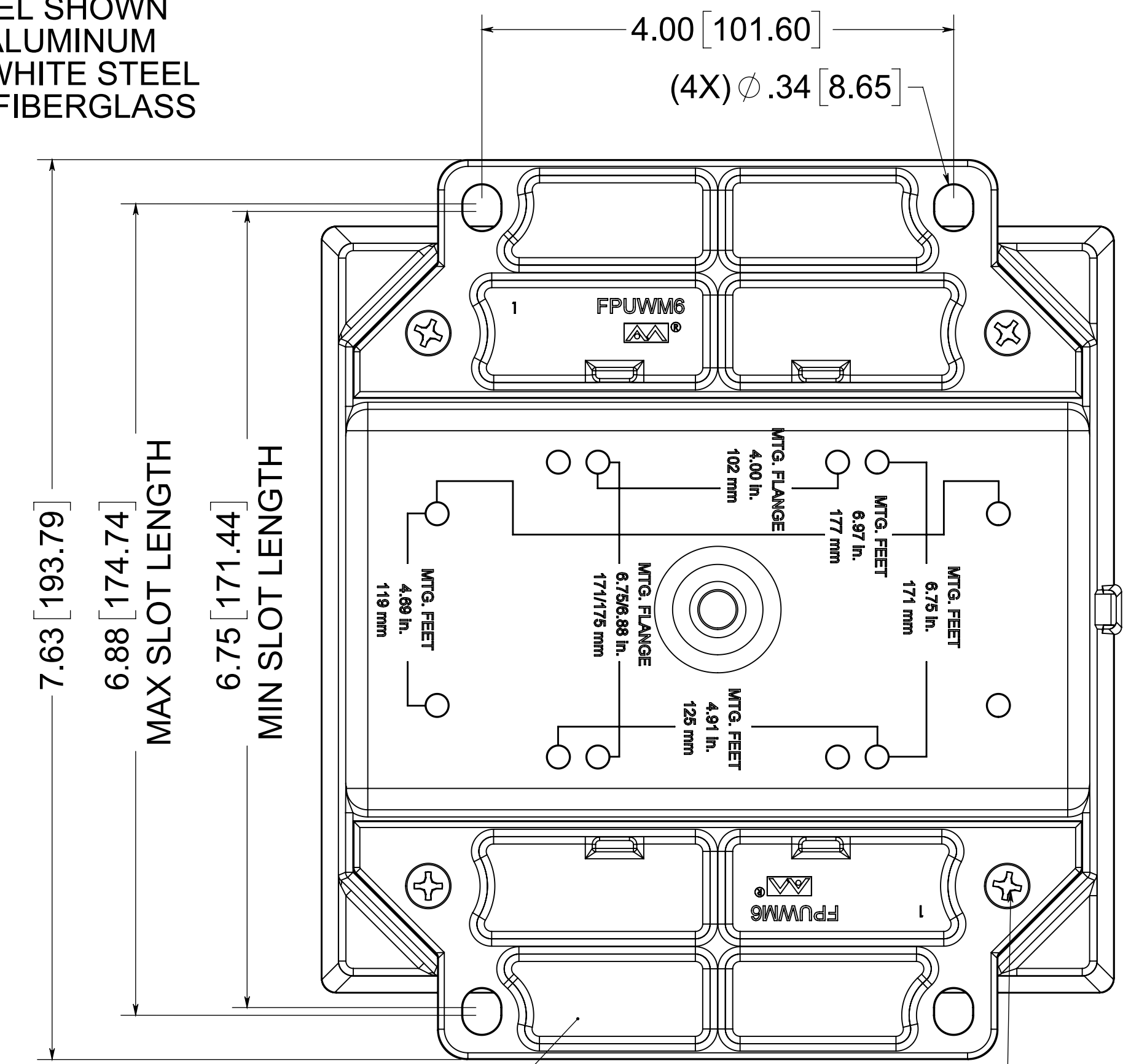

(2) POLYCARBONATE FLANGES (GLUED)

(4) EACH #10-32 BRASS INSERTS, AND 316 STAINLESS STEEL FLANGE AND FEET SCREWS

FIP POLYURETHANE GASKET

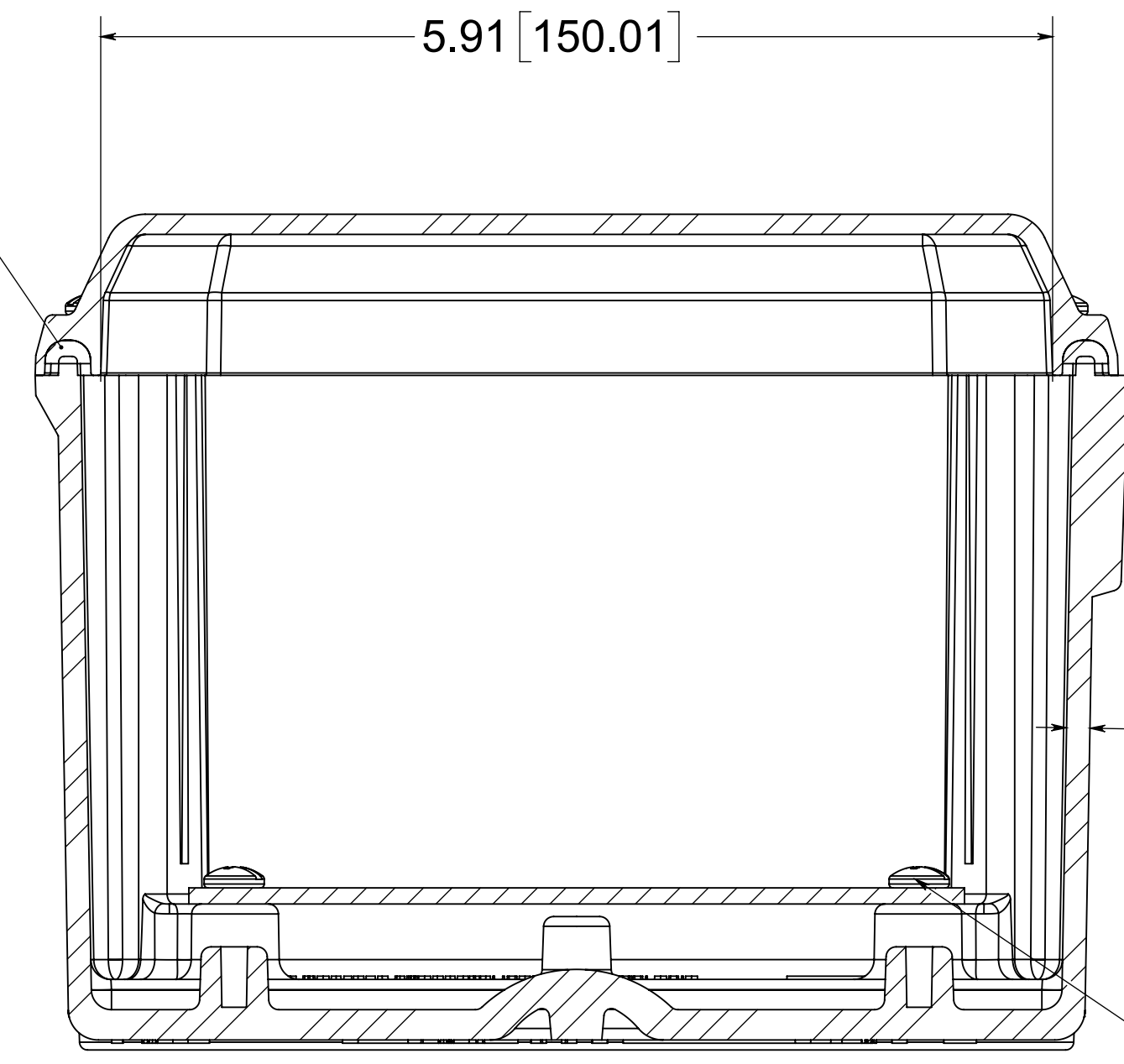

SECTION F-F

.14 [3.68] WALL THICKNESS

(4) EACH #10-32 BRASS INSERTS AND PLATED CARBON STEEL SCREWS

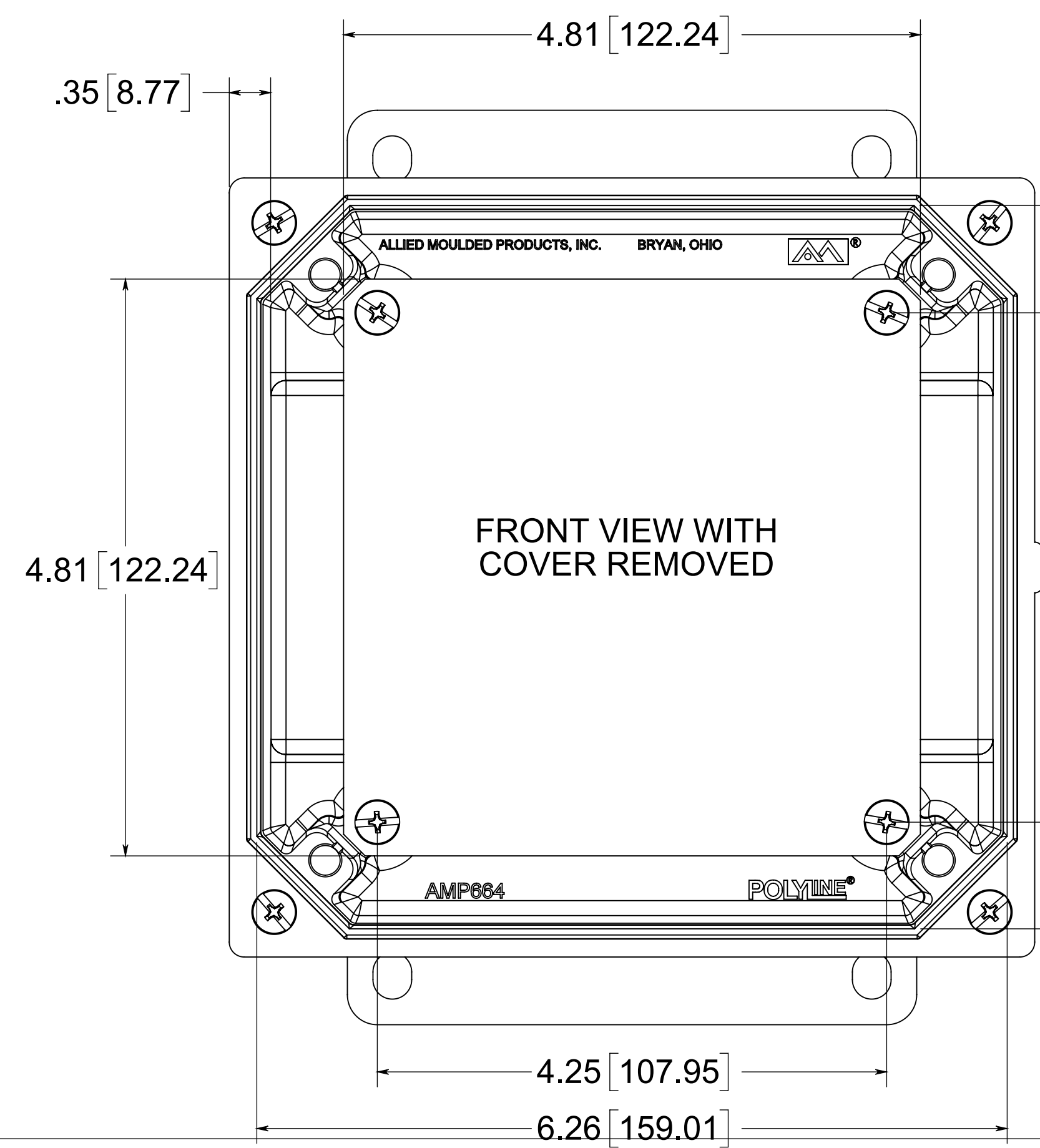

FRONT VIEW WITH COVER REMOVED

NOTE:  
 1. DATA SUBJECT TO CHANGE WITHOUT NOTICE

MATERIAL:  
 BOX- INJECTED POLYCARBONATE  
 STANDARD COVER- INJECTED POLYCARBONATE  
 CLEAR COVER- INJECTED POLYCARBONATE

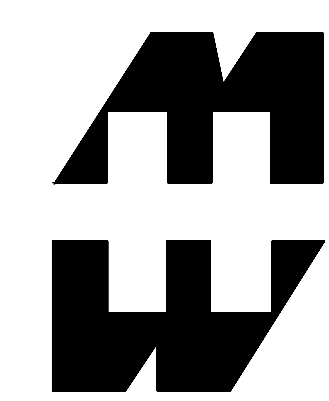

PART No. PCJ664F.WEB

for more information visit  
[www.hammfg.com](http://www.hammfg.com)  
 Data subject to change without notice  
 Drawing Not to Scale