

(4) EACH #10-32 BRASS INSERTS AND 316 STAINLESS STEEL CAPTIVE COVER SCREWS

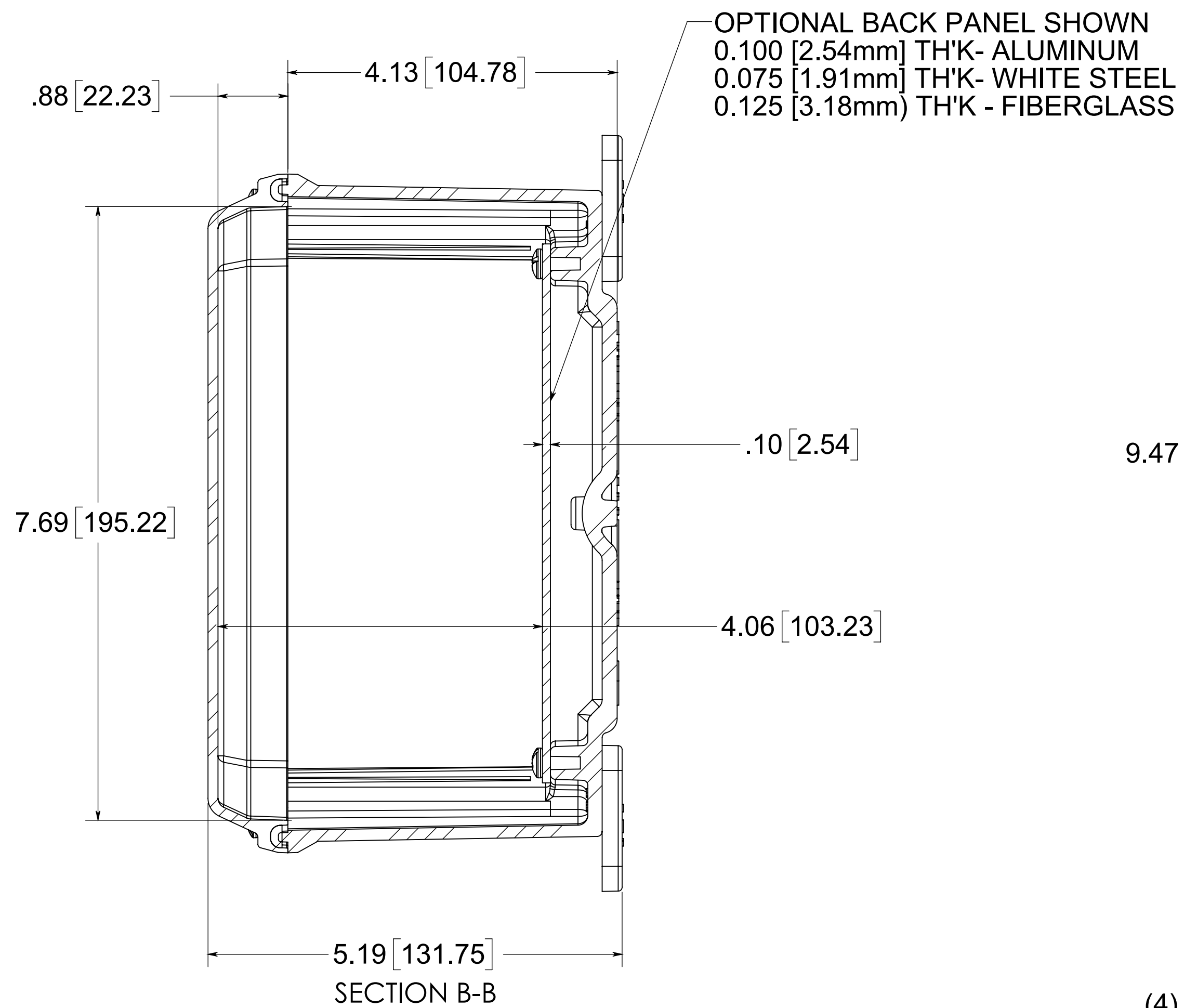

OPTIONAL BACK PANEL SHOWN
 0.100 [2.54mm] TH'K- ALUMINUM
 0.075 [1.91mm] TH'K- WHITE STEEL
 0.125 [3.18mm] TH'K - FIBERGLASS

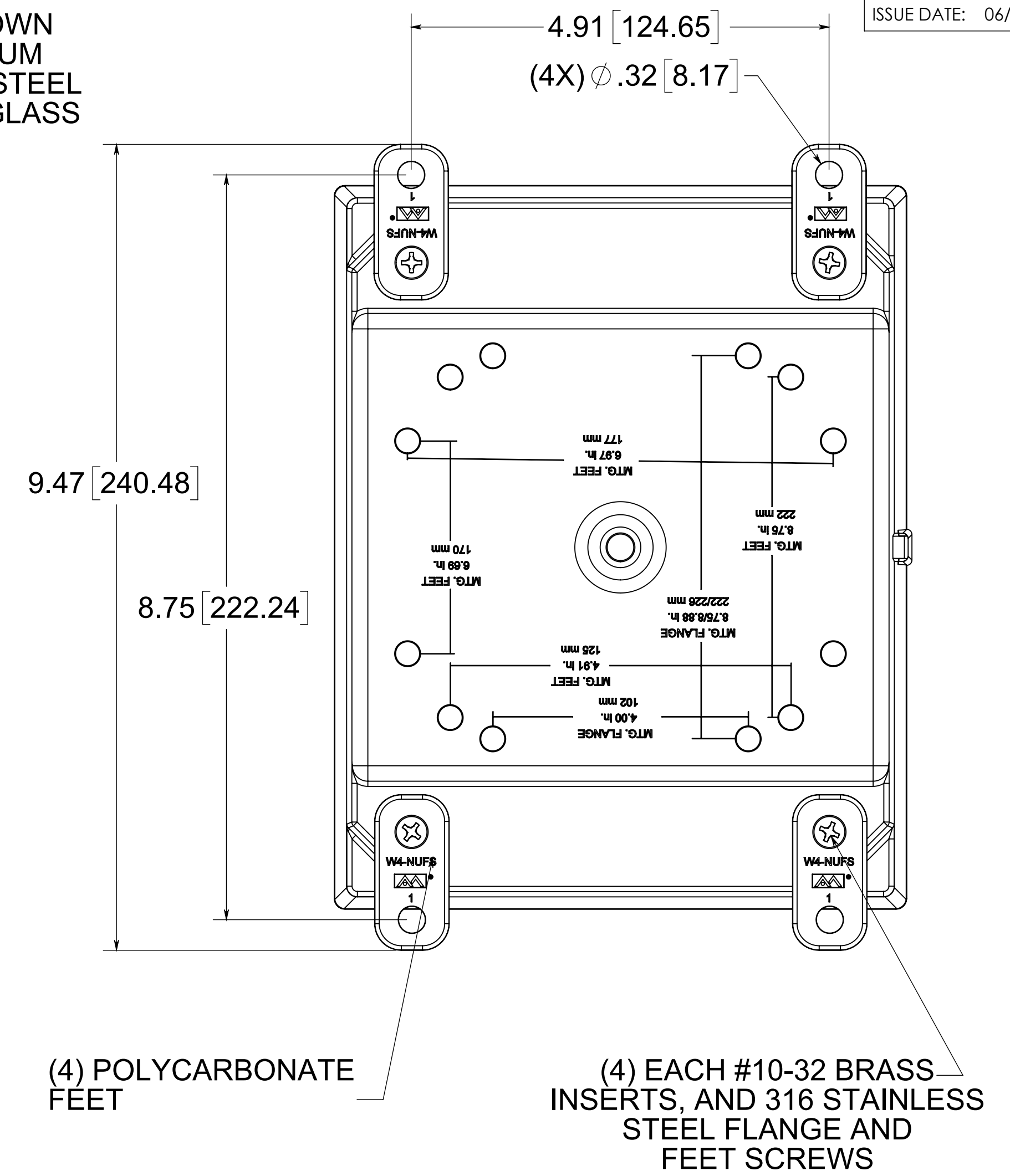

(4) POLYCARBONATE FEET

(4) EACH #10-32 BRASS INSERTS, AND 316 STAINLESS STEEL FLANGE AND FEET SCREWS

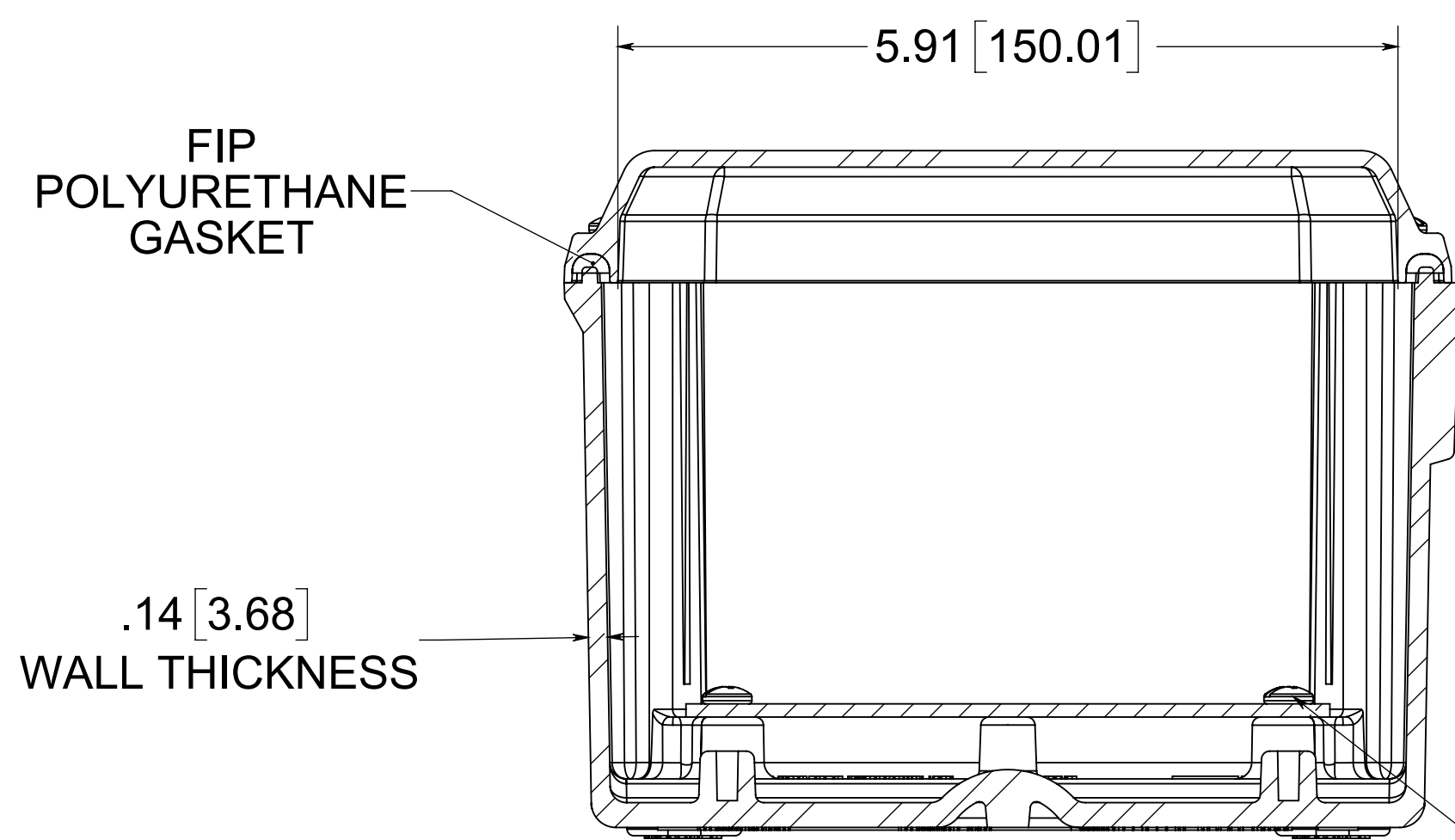

SECTION A-A

(4) EACH #10-32 BRASS INSERTS AND PLATED CARBON STEEL TRUSS SCREW

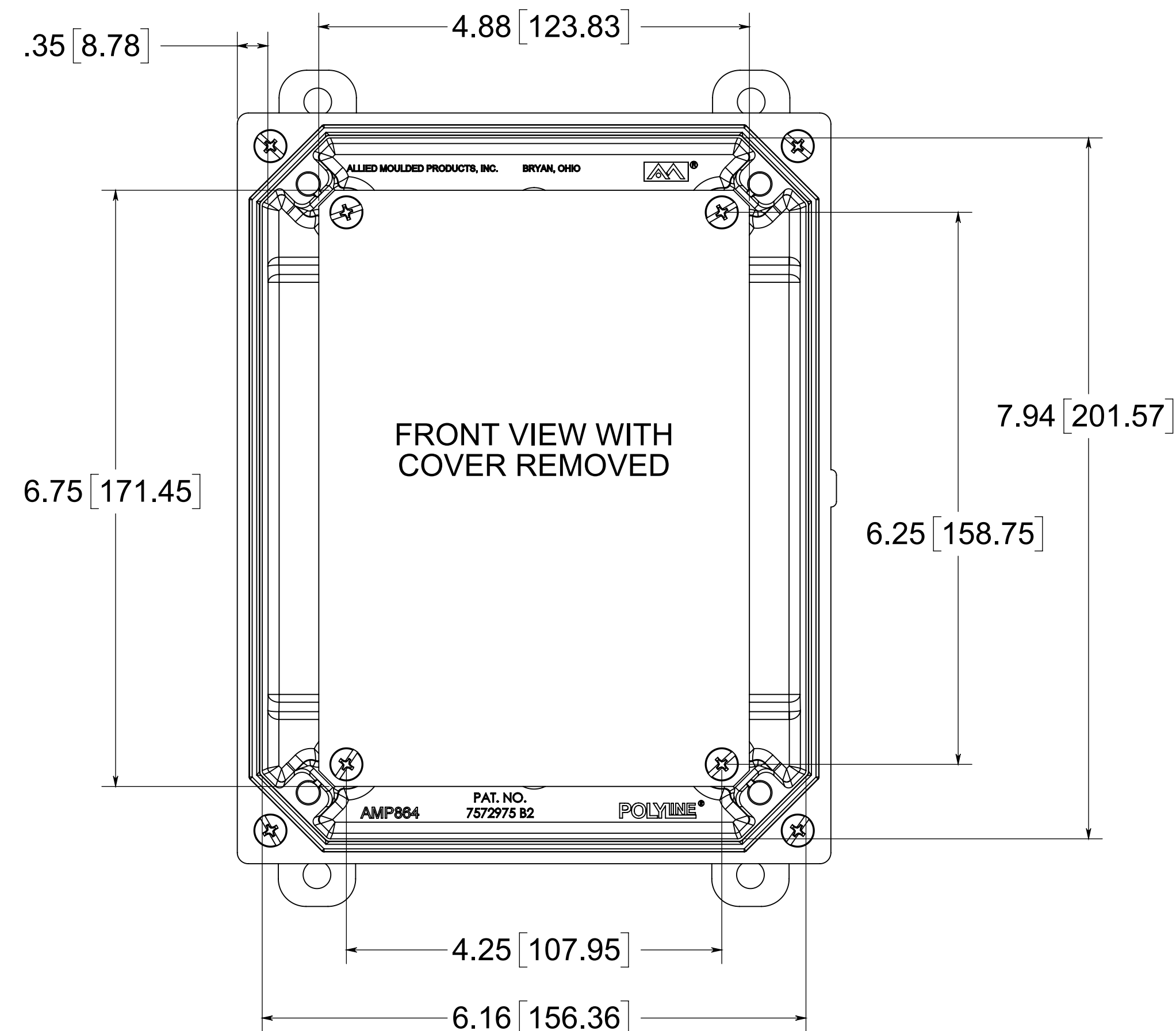

FRONT VIEW WITH COVER REMOVED

NOTE:
 1. DATA SUBJECT TO CHANGE

MATERIAL:
 BOX- INJECTED POLYCARBONATE
 STANDARD COVER- INJECTED POLYCARBONATE
 CLEAR COVER - INJECTED POLYCARBONATE

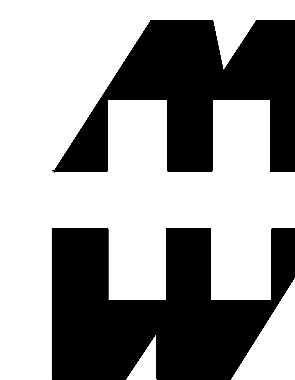

PART No. PCJ864CC.WEB

for more information visit
www.hammfg.com
 Data subject to change without notice

Drawing Not to Scale