

OPTIONAL BACK PANEL SHOWN
 0.100 [2.54mm] TH'K- ALUMINUM
 0.075 [1.91mm] TH'K- WHITE STEEL

(4) EACH #10-32 BRASS INSERTS, AND STAINLESS STEEL FLANGE AND FEET SCREWS

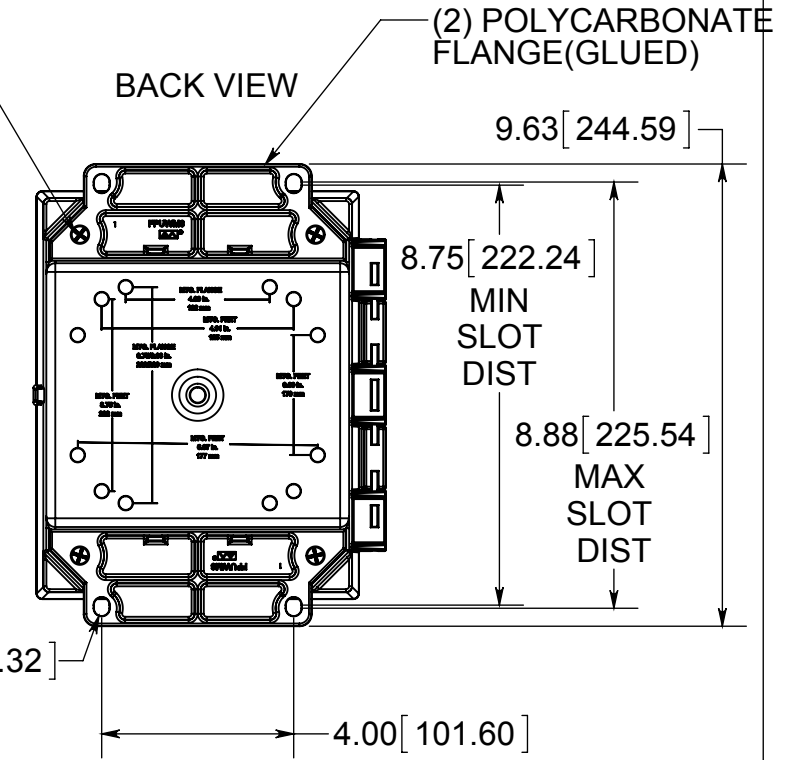

FRONT VIEW WITH COVER REMOVED AND BACK PANEL DISPLAYED

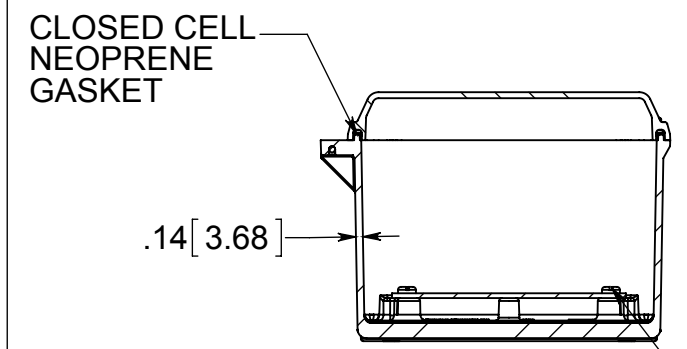
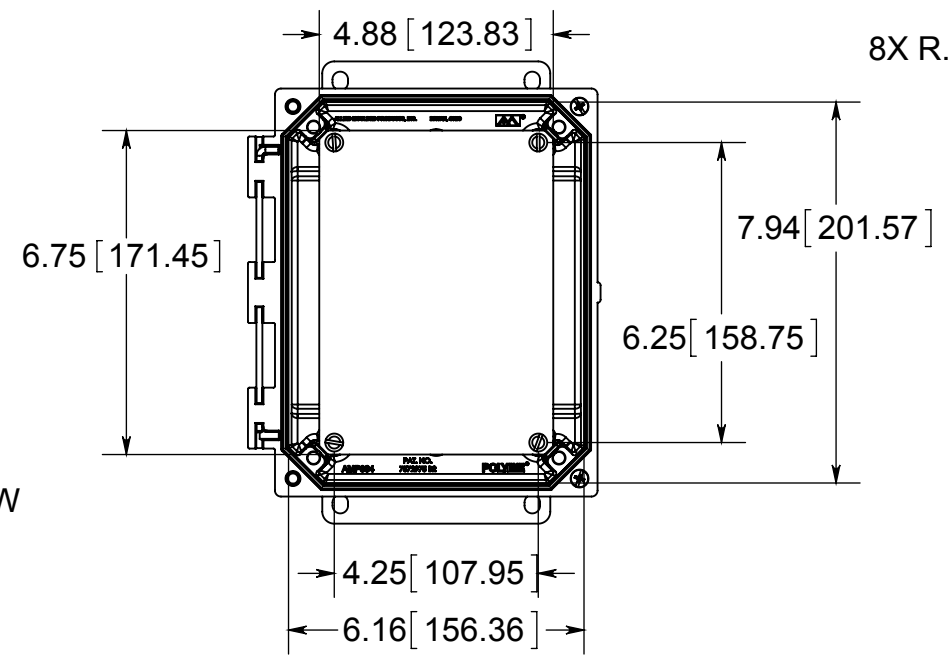

(4) EACH #10-32 BRASS INSERTS AND PLATED CARBON STEEL TRUSS SCREW

MATERIAL:
 BOX- INJECTED POLYCARBONATE
 STANDARD COVER- INJECTED POLYCARBONATE
 CLEAR COVER - INJECTED POLYCARBONATE

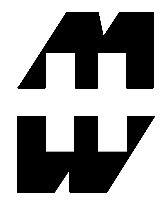

PART No. PCJ864HF

for more information visit www.hammfg.com
 Data subject to change without notice
 Drawing Not to Scale