

(4X) EACH #10-32 BRASS INSERTS AND 316 STAINLESS STEEL CAPTIVE COVER SCREWS

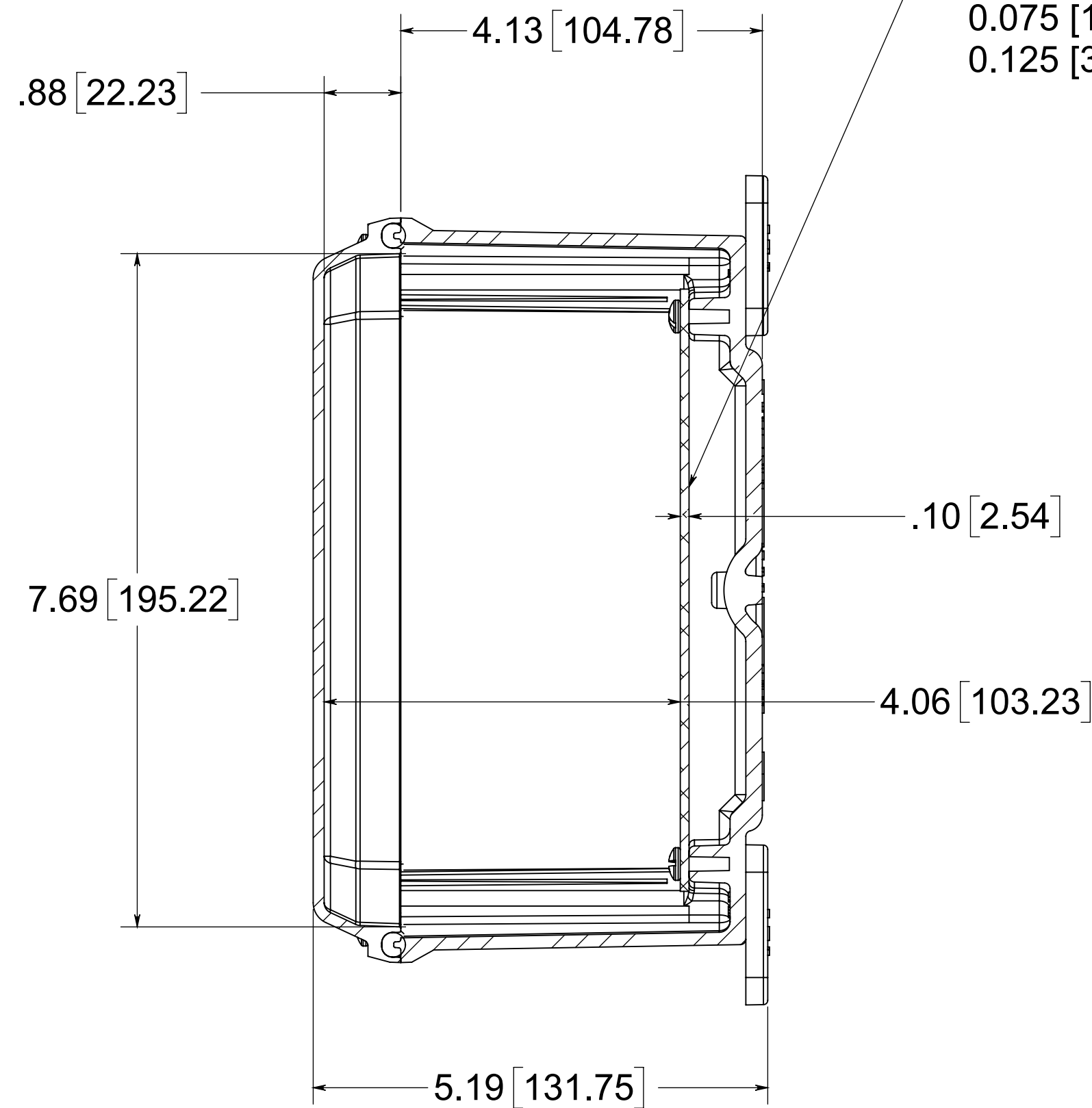

SECTION B-B

OPTIONAL BACK PANEL  
 0.100 [2.54mm] TH'K - ALUMINUM  
 0.075 [1.91mm] TH'K - WHITE STEEL  
 0.125 [3.18mm] TH'K - FIBERGLASS

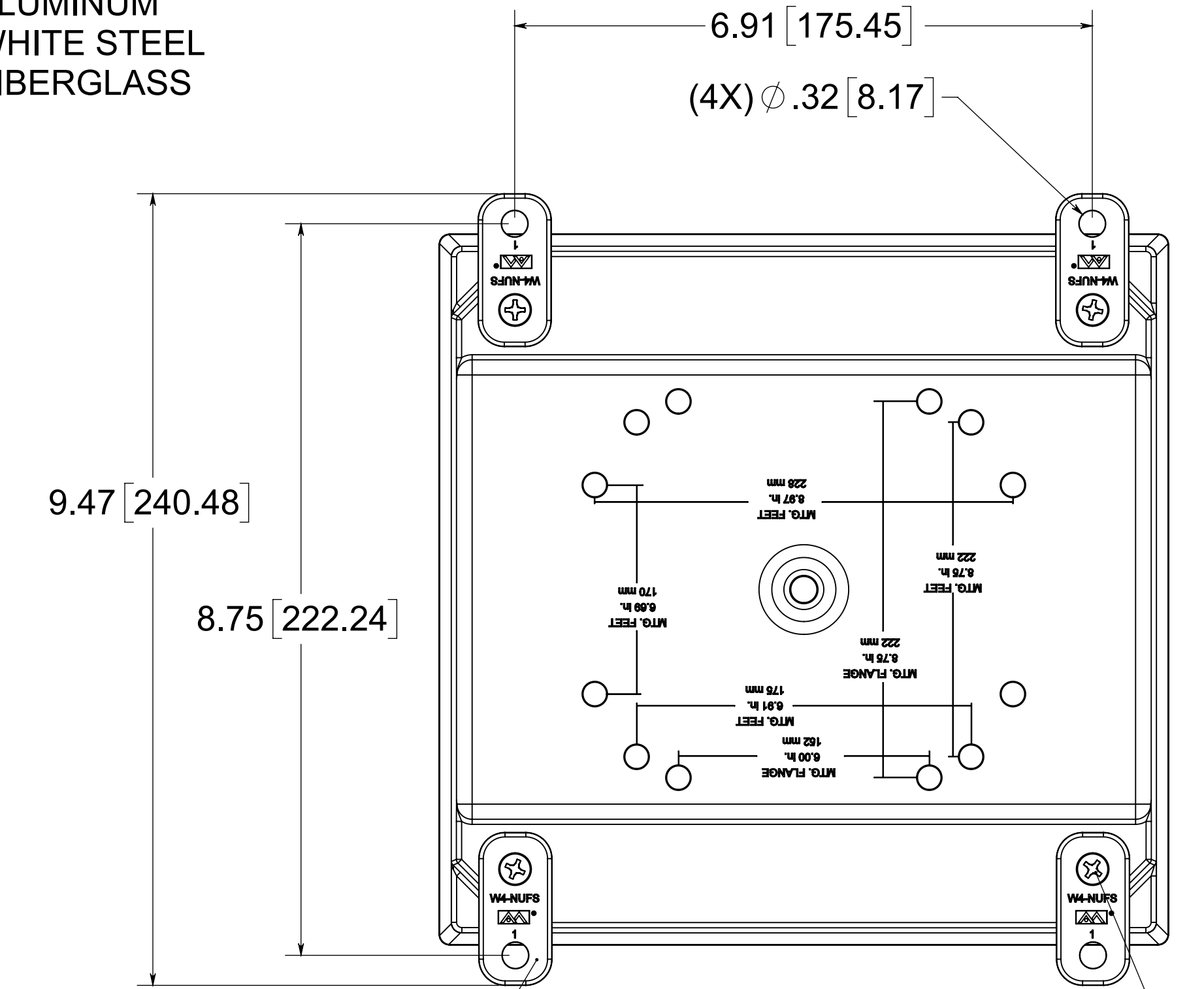

(4X) POLYCARBONATE FEET

(4X) EACH #10-32 BRASS INSERTS, AND 316 STAINLESS STEEL FLANGE AND FEET SCREWS

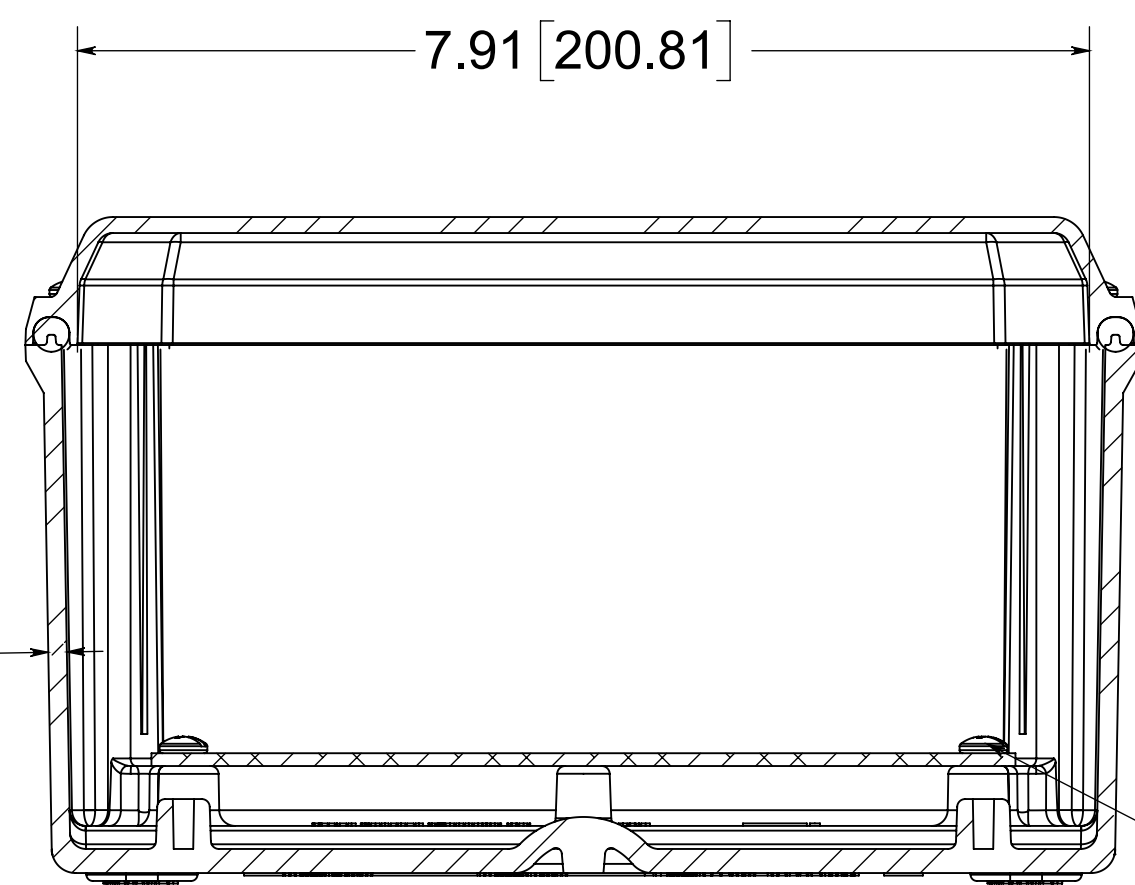

SECTION A-A

(4X) EACH #10-32 BRASS INSERTS AND PLATED CARBON STEEL SCREWS

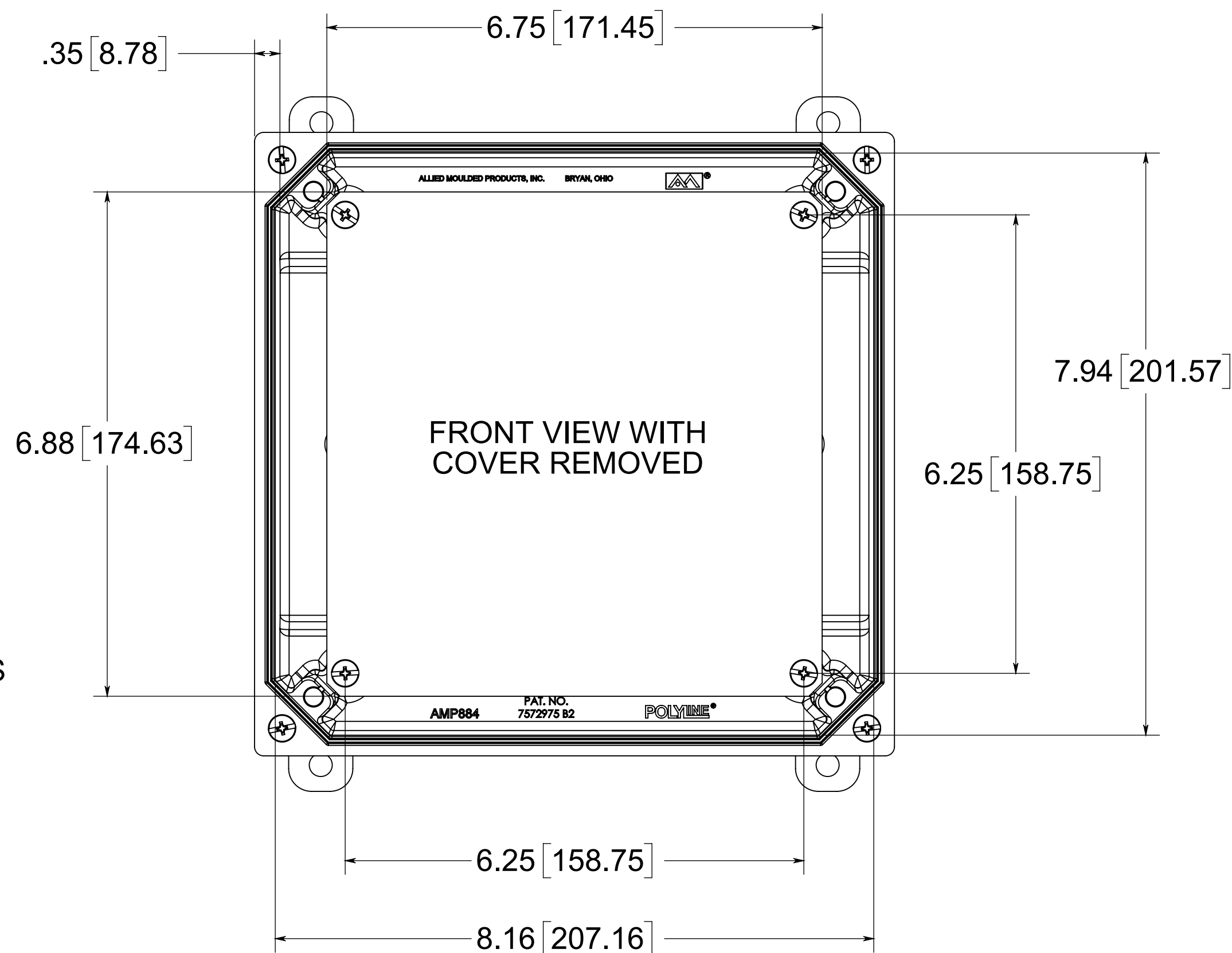

FRONT VIEW WITH COVER REMOVED

NOTE:  
 1. DATA SUBJECT TO CHANGE

MATERIAL:  
 BOX- INJECTED POLYCARBONATE  
 STANDARD COVER- INJECTED POLYCARBONATE  
 CLEAR COVER - INJECTED POLYCARBONATE

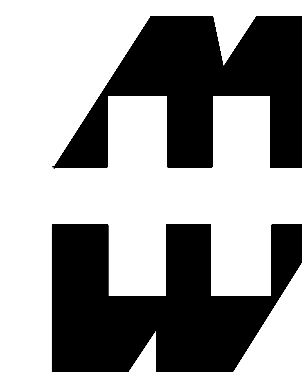

PART No. PCJ884.WEB

for more information visit  
[www.hammfg.com](http://www.hammfg.com)  
 Data subject to change without notice

Drawing Not to Scale