

(4X) EACH #10-32 BRASS INSERTS AND 316 STAINLESS STEEL CAPTIVE COVER SCREWS WITH RETAINING O-RING

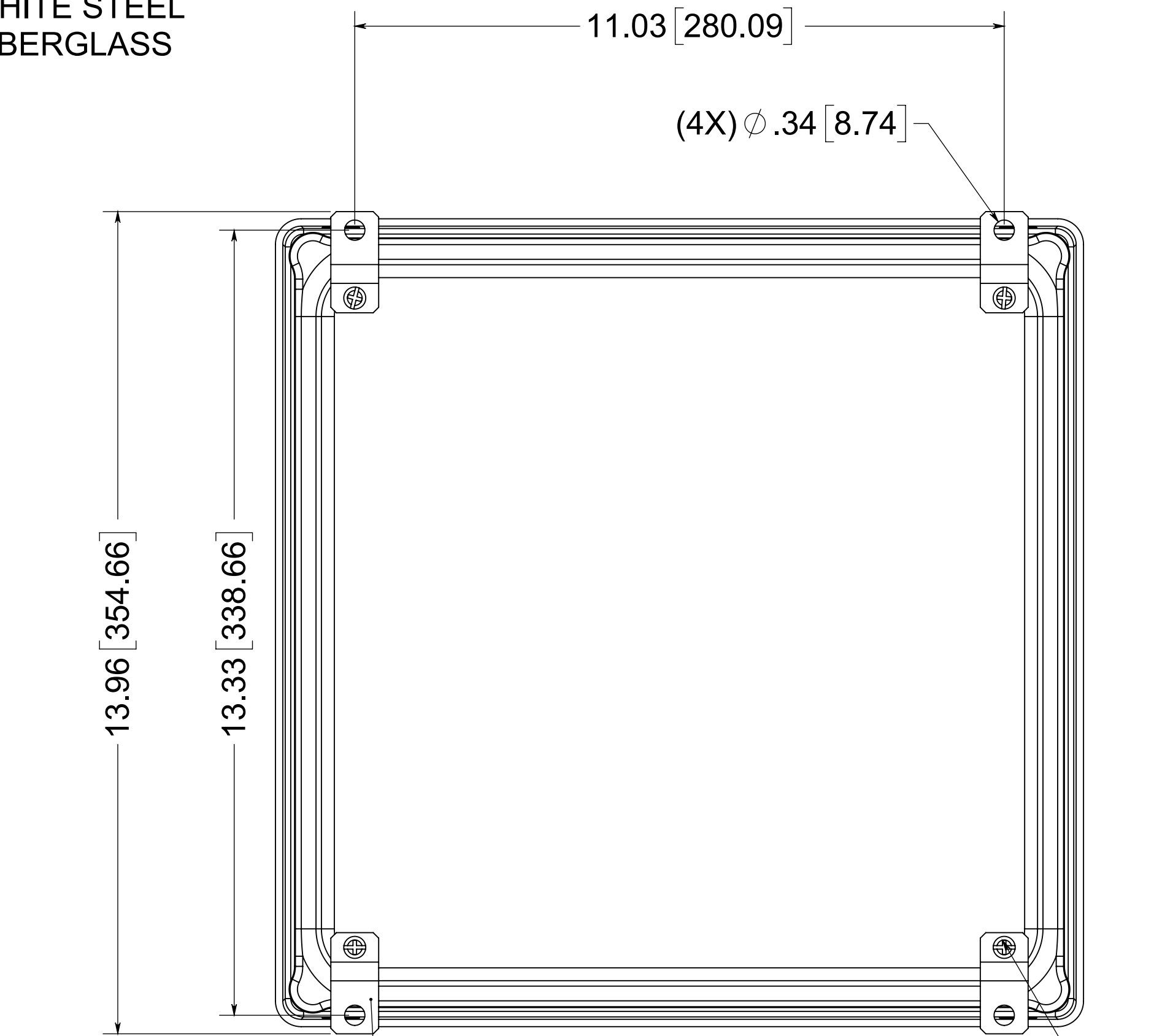

(4X) 316 STAINLESS STEEL FEET

(4X) EACH #10-32 BRASS INSERTS, AND 316 STAINLESS STEEL FEET SCREWS

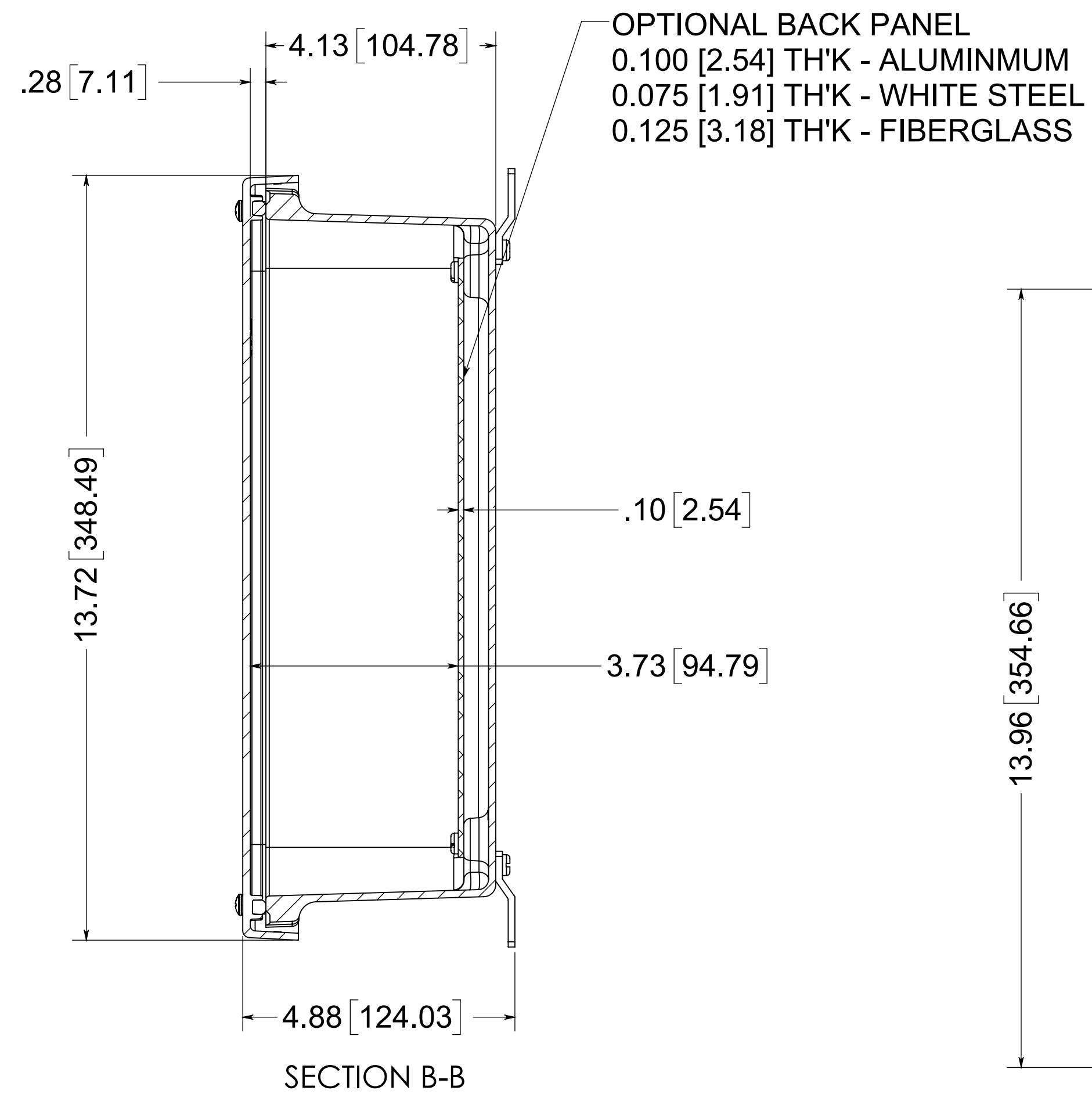
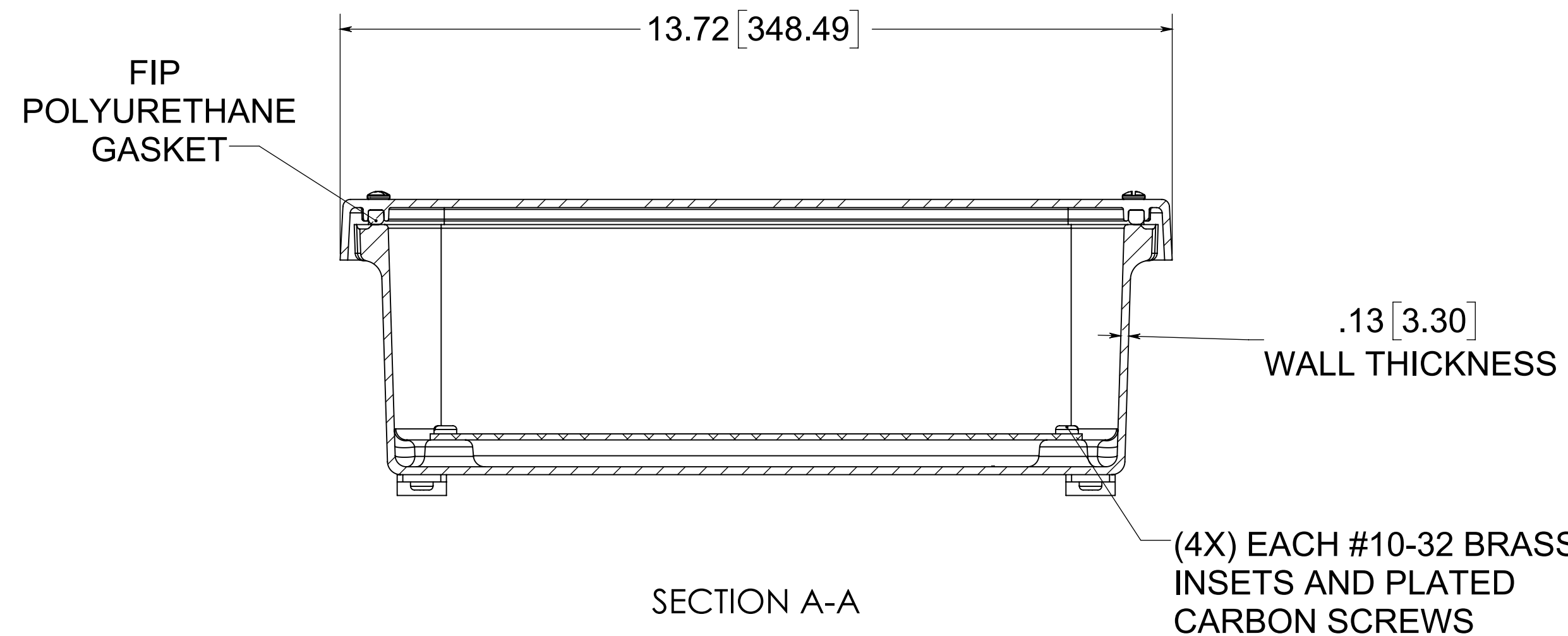

SECTION A-A

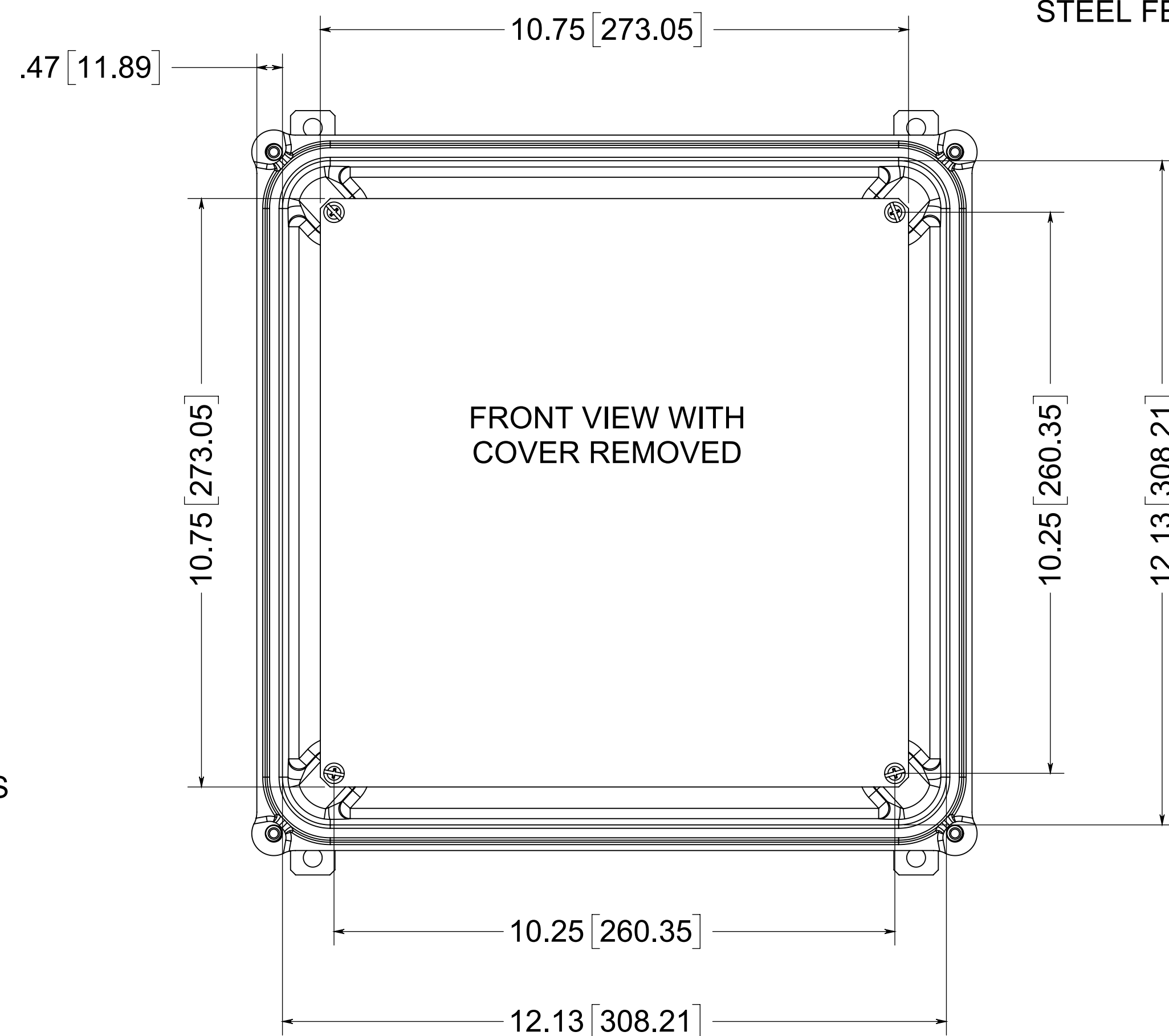

FRONT VIEW WITH COVER REMOVED

MATERIAL:
 BOX-COMPRESSION MOLDED FIBERGLASS REINFORCED POLYESTER
 COVER-COMPRESSION MOLDED FIBERGLASS REINFORCED POLYESTER
 WINDOWS-POLYCARBONATE

NOTE:
 1. DATA SUBJECT TO CHANGE WITHOUT NOTICE

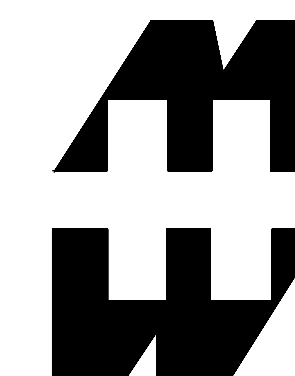

PART No. PJ12124

for more information visit
www.hammfg.com
 Data subject to change without notice
 Drawing Not to Scale