

(4X) EACH #10-32 BRASS INSERTS AND 316 STAINLESS STEEL CAPTIVE COVER SCREWS WITH RETAINING O-RING

OPTIONAL BACK PANEL
 0.100 [2.54] TH'K - ALUMINUM
 0.075 [1.91] TH'K - WHITE STEEL
 0.125 [3.18] TH'K - FIBERGLASS

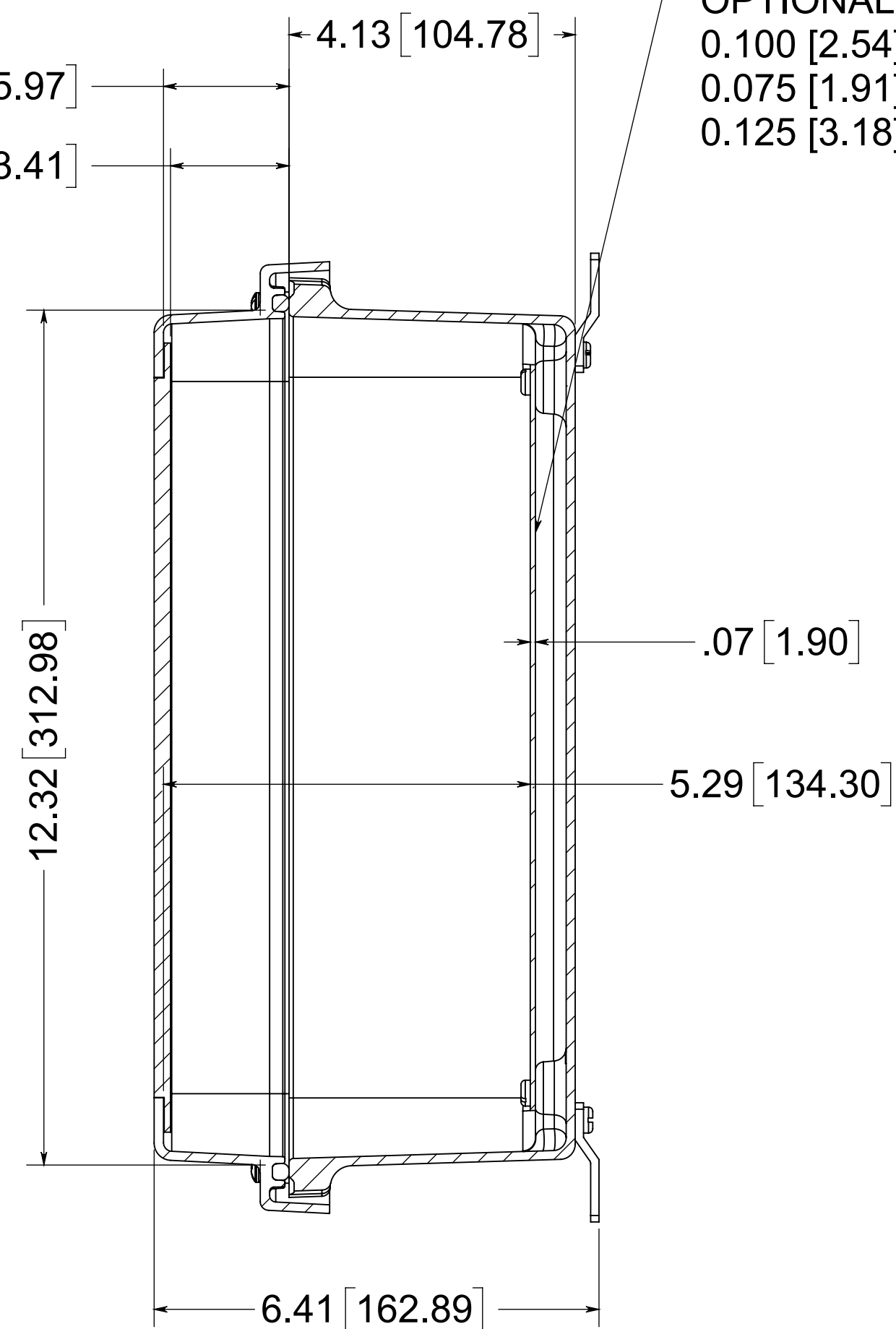

SECTION B-B

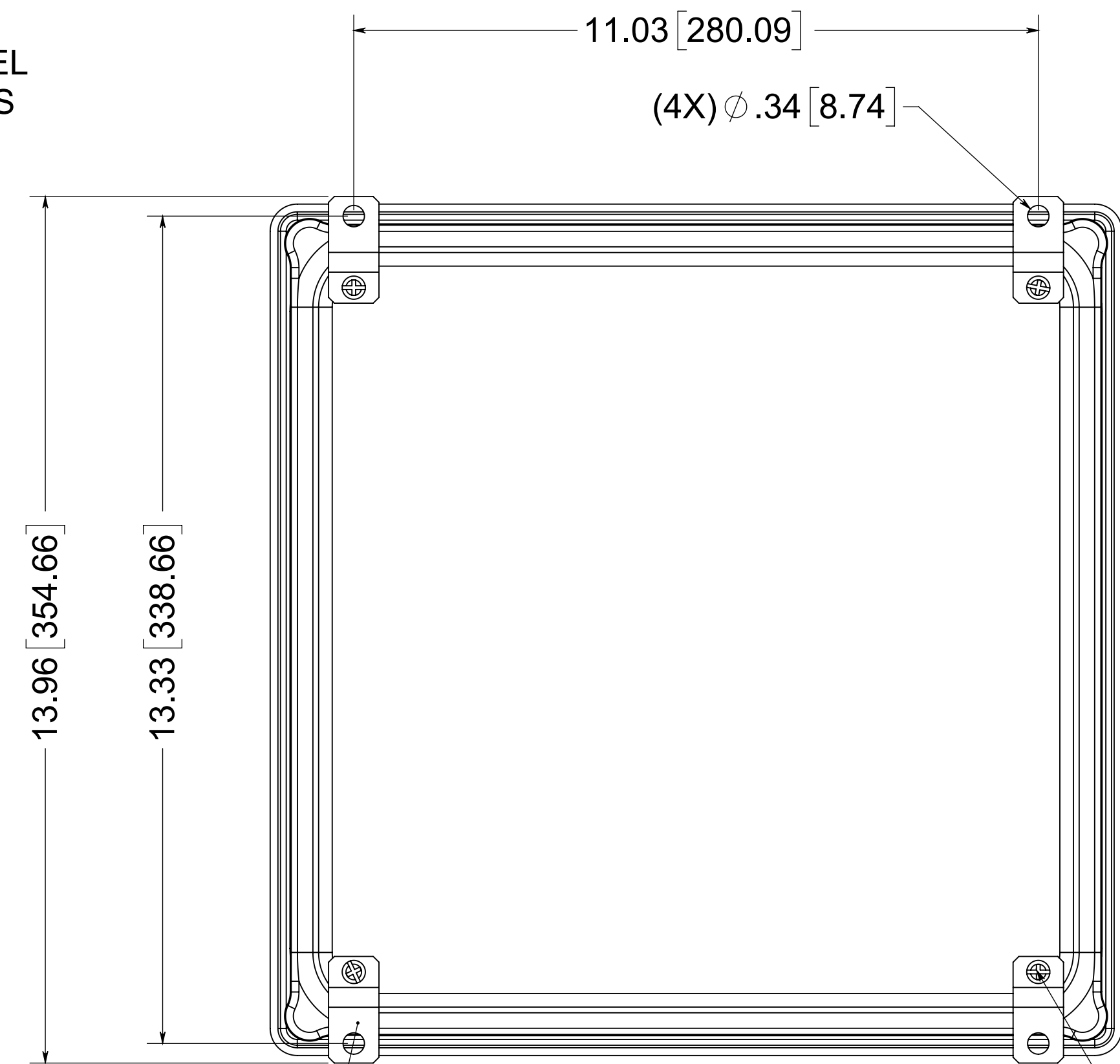

(4X) 316 STAINLESS STEEL FEET

(4X) EACH #10-32 BRASS INSERTS, AND 316 STAINLESS STEEL FEET SCREWS

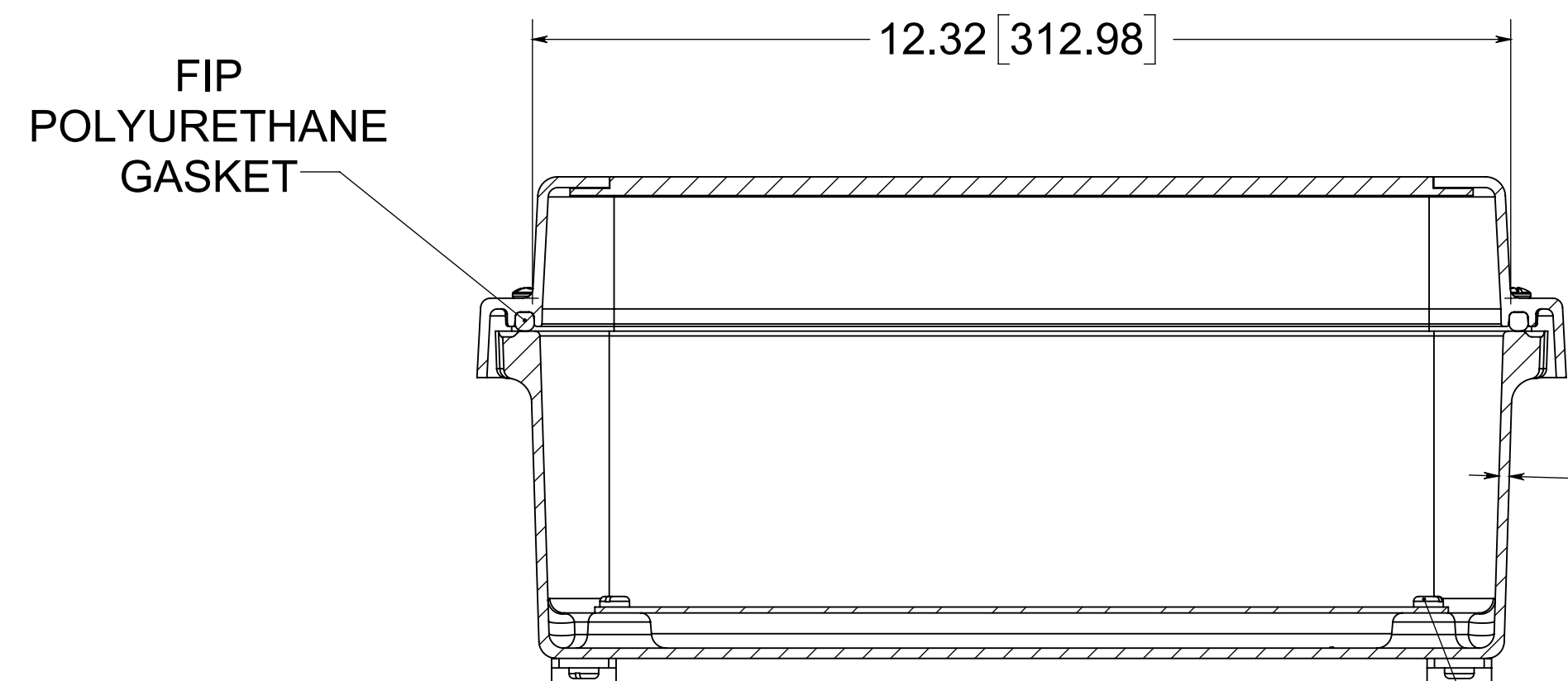

SECTION A-A

(4X) EACH #10-32 BRASS INSERTS AND PLATED CARBON STEEL SCREWS

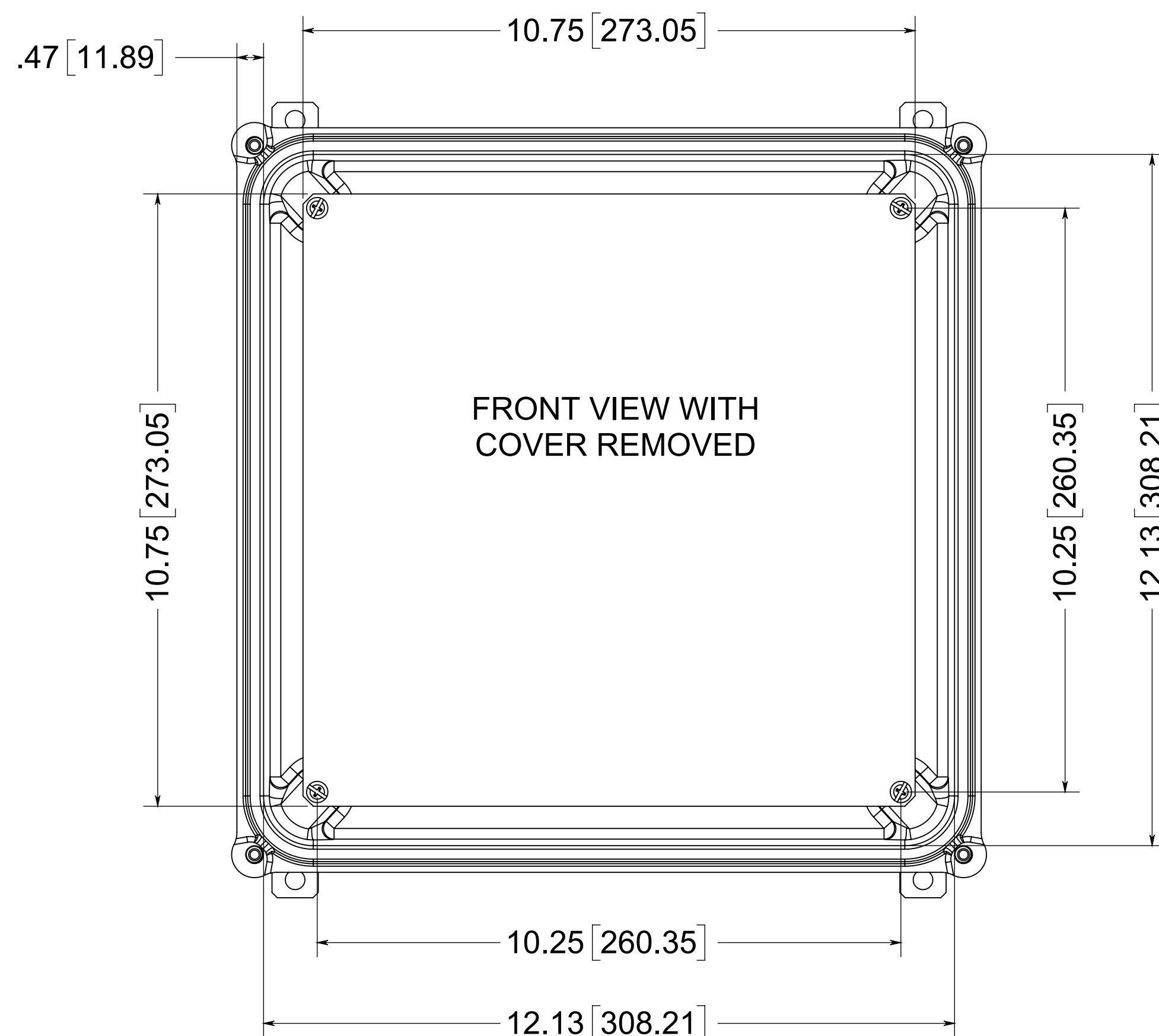

FRONT VIEW WITH COVER REMOVED

MATERIAL:
 BOX - COMPRESSION MOLDED FIBERGLASS REINFORCED POLYESTER
 COVER - COMPRESSION MOLDED FIBERGLASS REINFORCED POLYESTER
 WINDOWS - POLYCARBONATE

NOTE:
 1. DATA SUBJECT TO CHANGE WITHOUT NOTICE

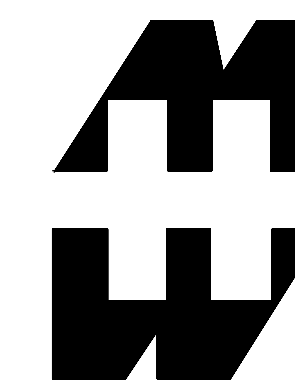

PART No. PJ12124RW

for more information visit
www.hammfg.com
 Data subject to change without notice
 Drawing Not to Scale