

SECTION B-B

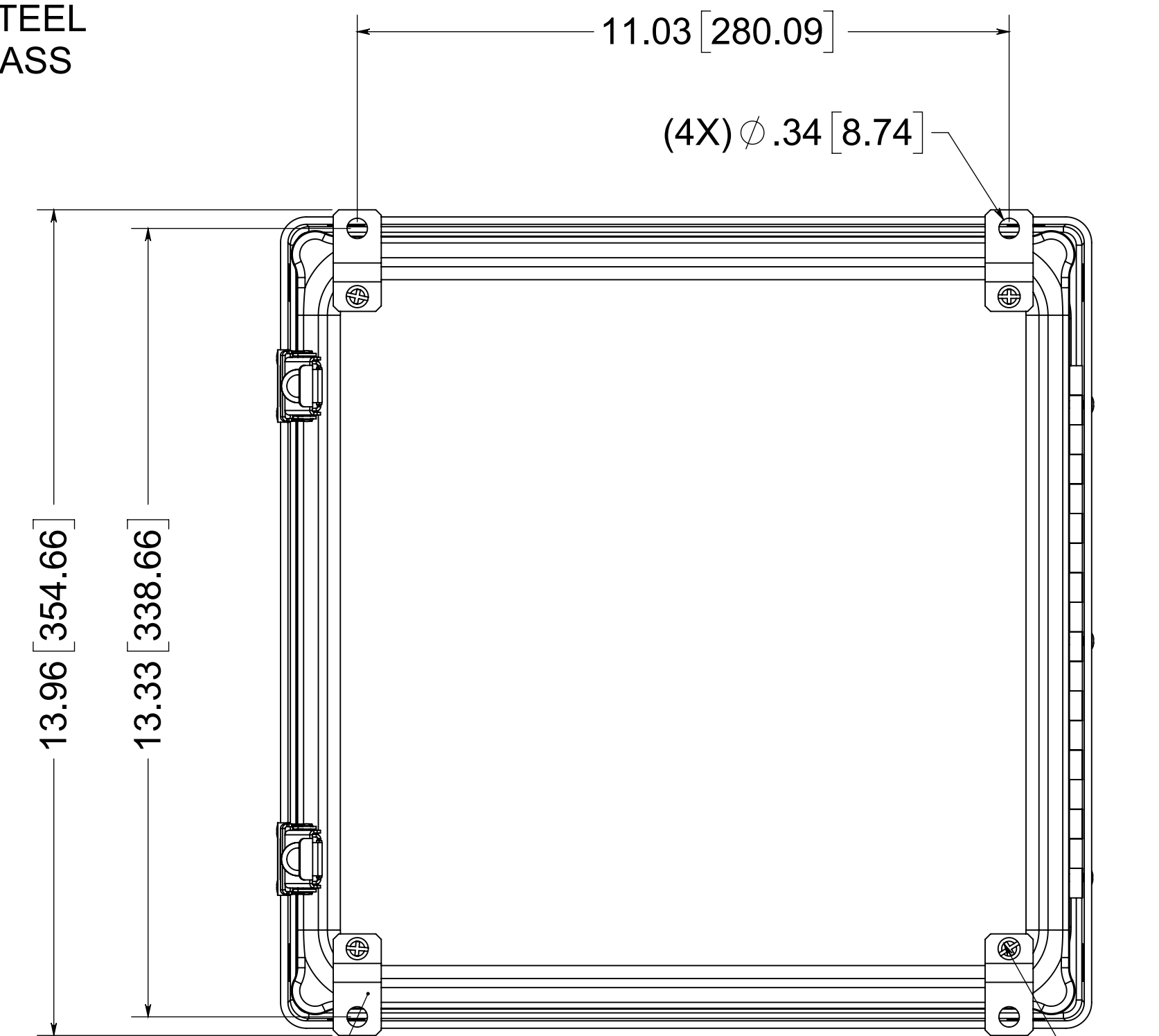

(4X) 316 STAINLESS STEEL FEET

(4X) EACH #10-32 BRASS INSERTS, AND 316 STAINLESS STEEL FEET SCREWS

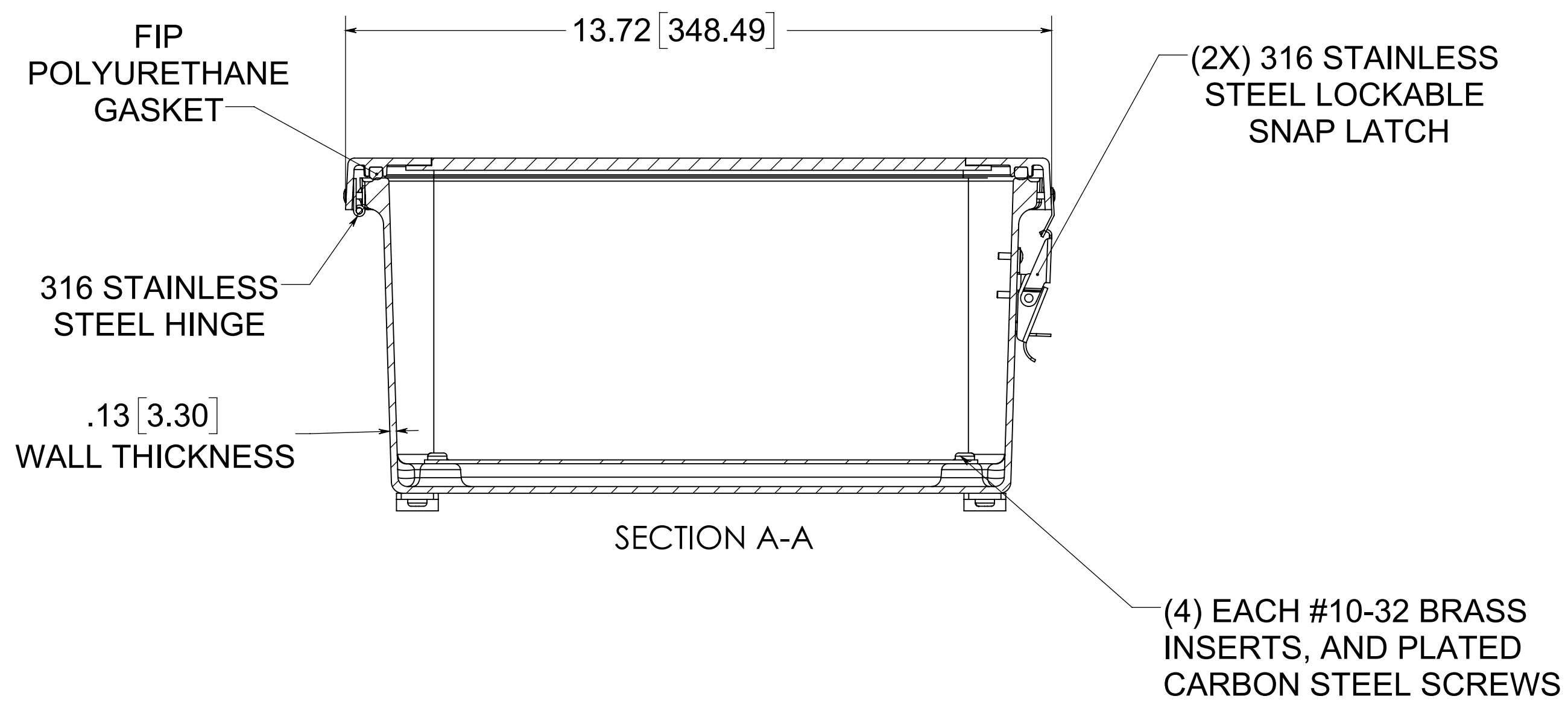

SECTION A-A

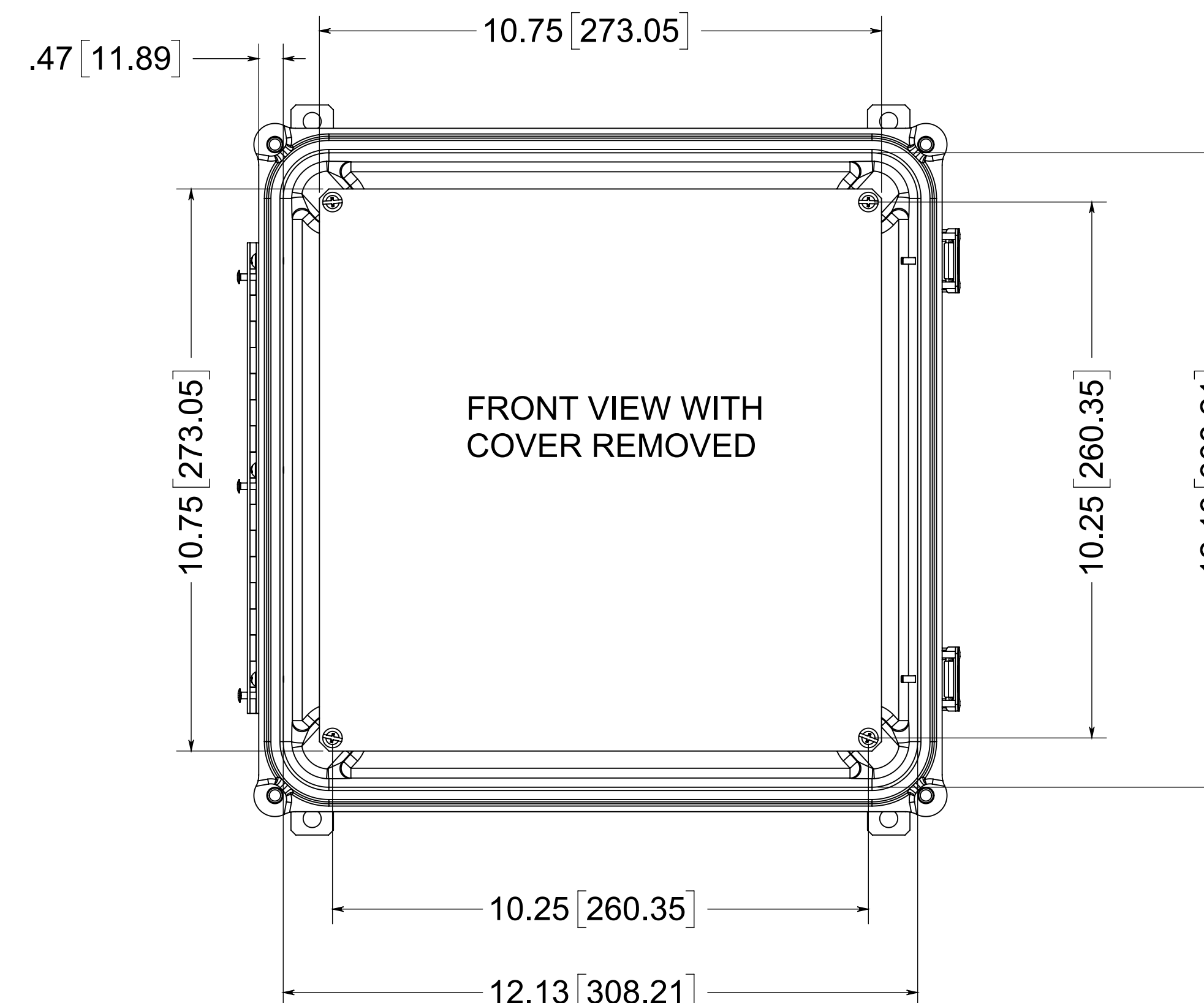

FRONT VIEW WITH COVER REMOVED

MATERIAL:
 BOX- COMPRESSION MOLDED FIBERGLASS REINFORCED POLYESTER
 COVER- COMPRESSION MOLDED FIBERGLASS REINFORCED POLYESTER
 WINDOWS- POLYCARBONATE

NOTES:
 1. DATA SUBJECT TO CHANGE WITHOUT NOTICE

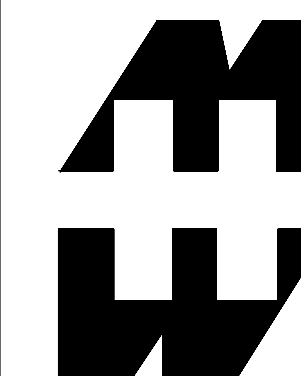

PART No. PJ12126LW

for more information visit
www.hammfg.com
 Data subject to change without notice

Drawing Not to Scale