

OPTIONAL BACK PANEL
 0.100 [2.54] TH'K- ALUMINUM
 0.075 [1.91] TH'K- WHITE STEEL
 0.125 [3.18] TH'K- FIBERGLASS

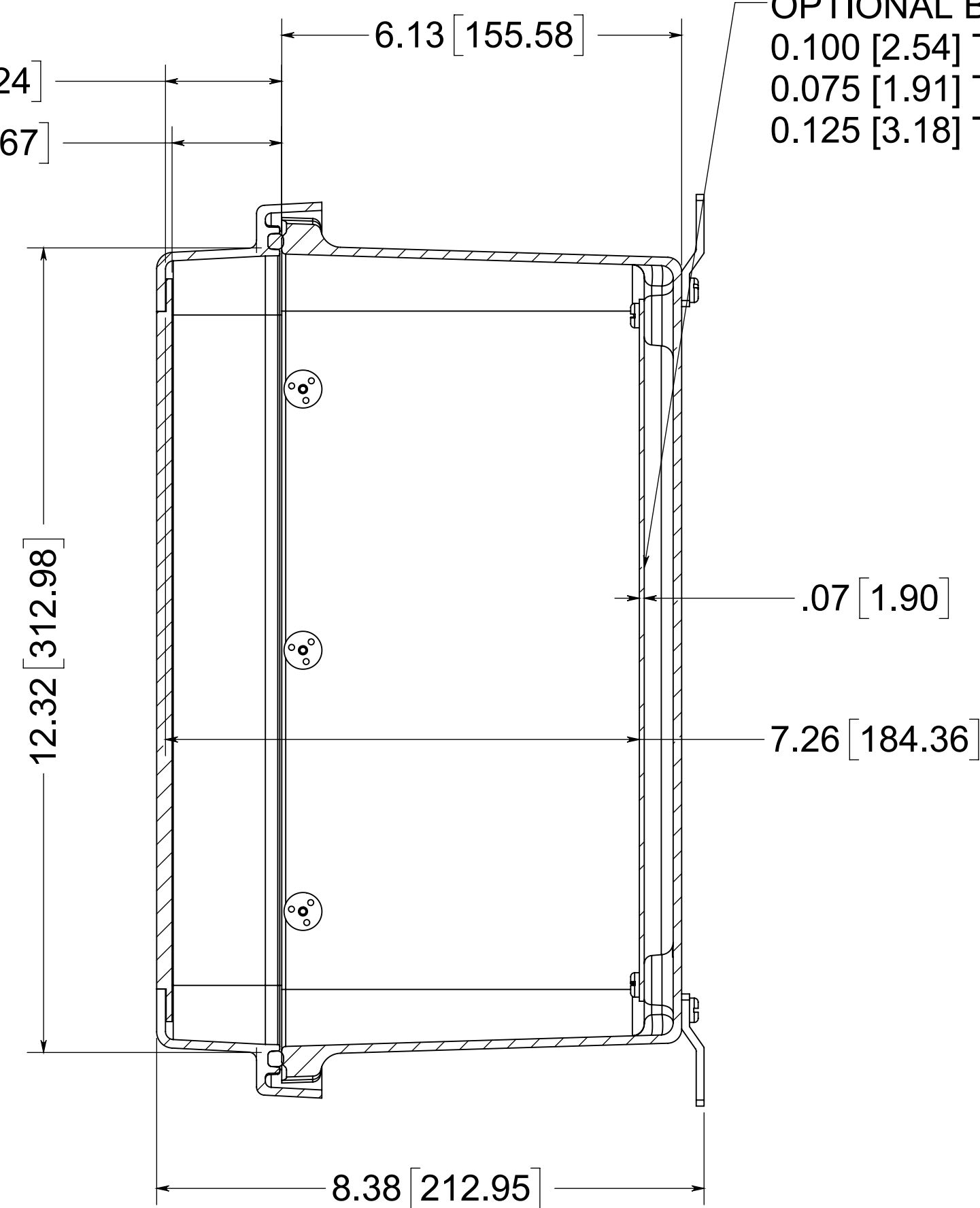

SECTION A-A

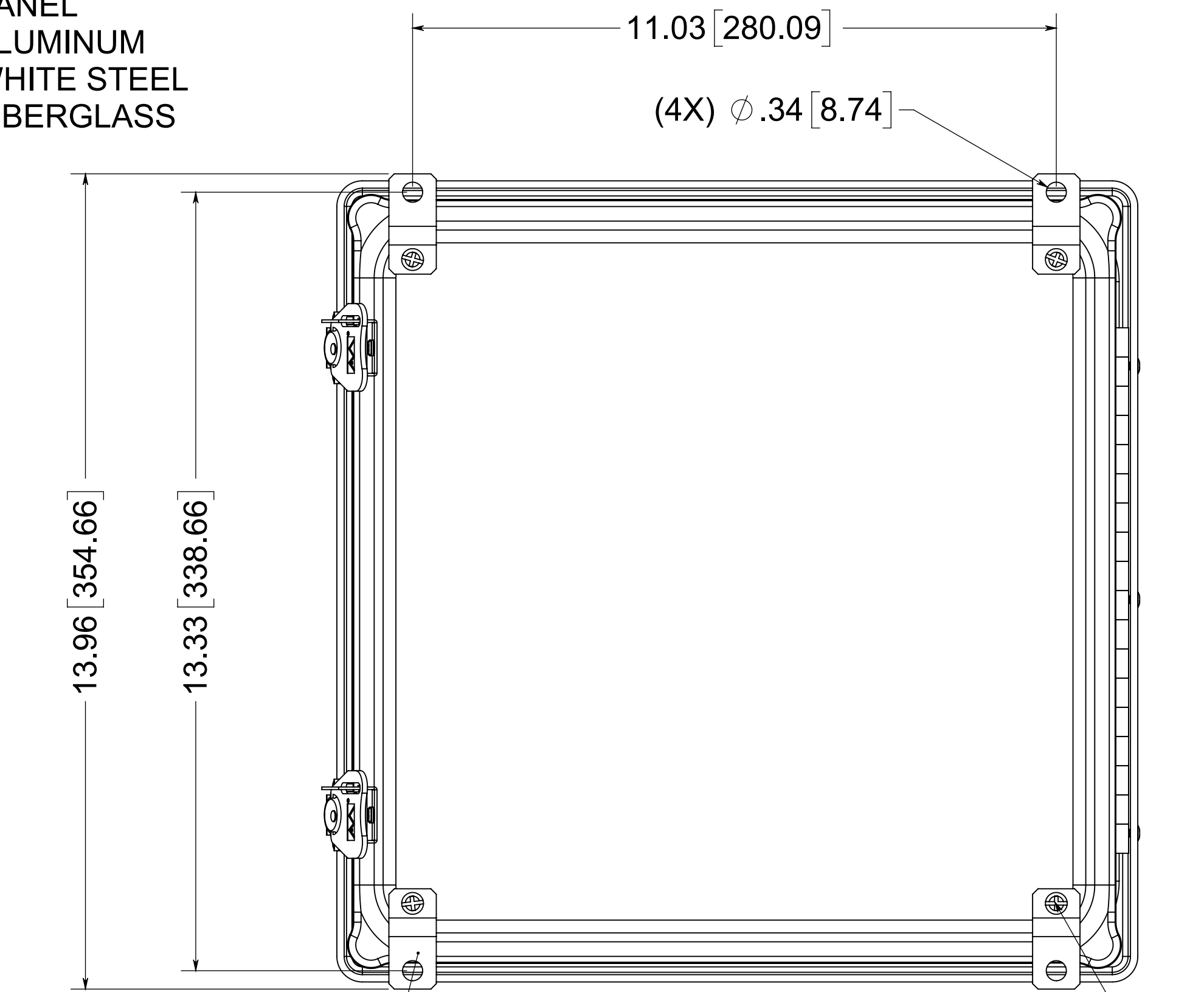

(4X) 316 STAINLESS STEEL FEET

(4X) EACH #10-32 BRASS INSERTS, AND 316 STAINLESS STEEL FEET SCREWS

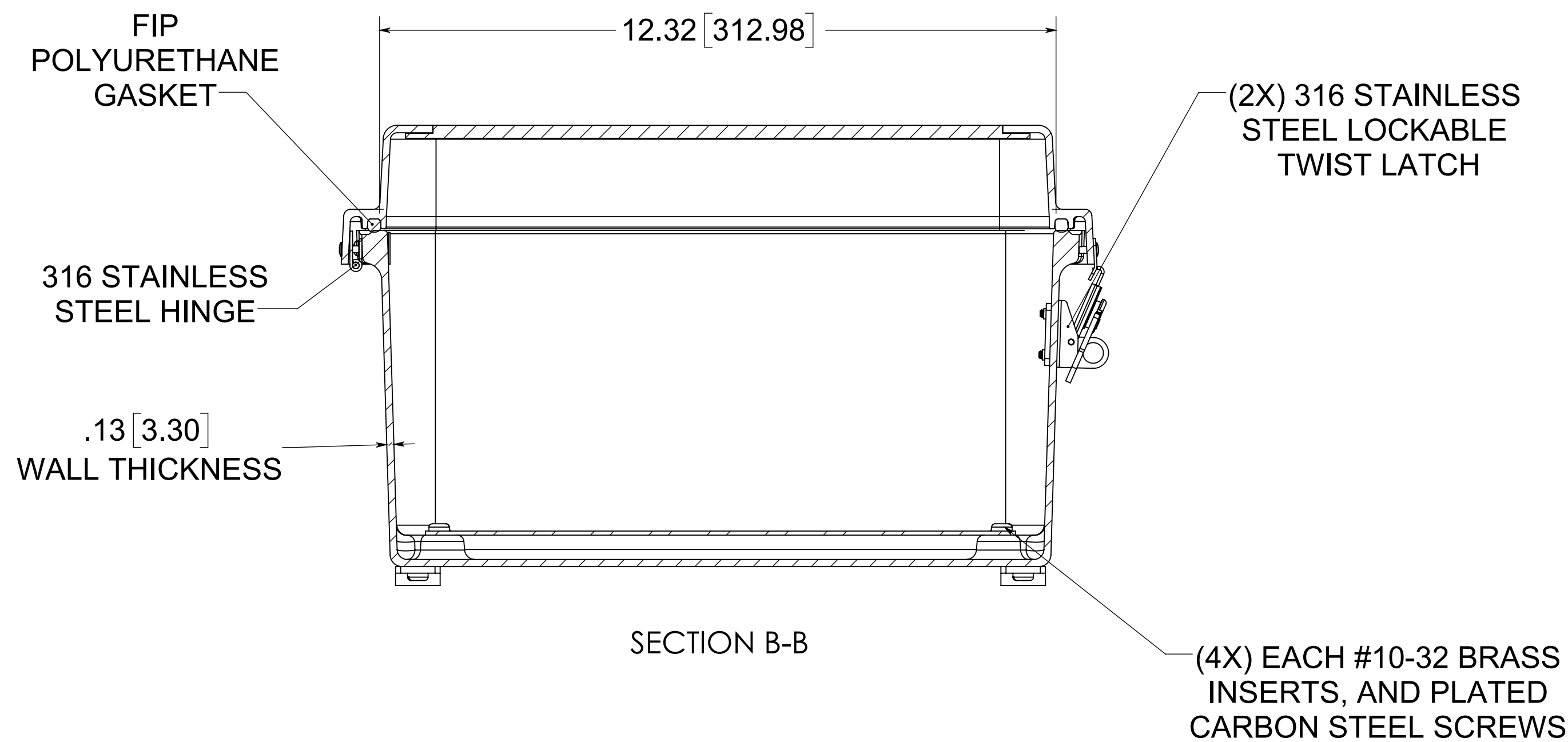

SECTION B-B

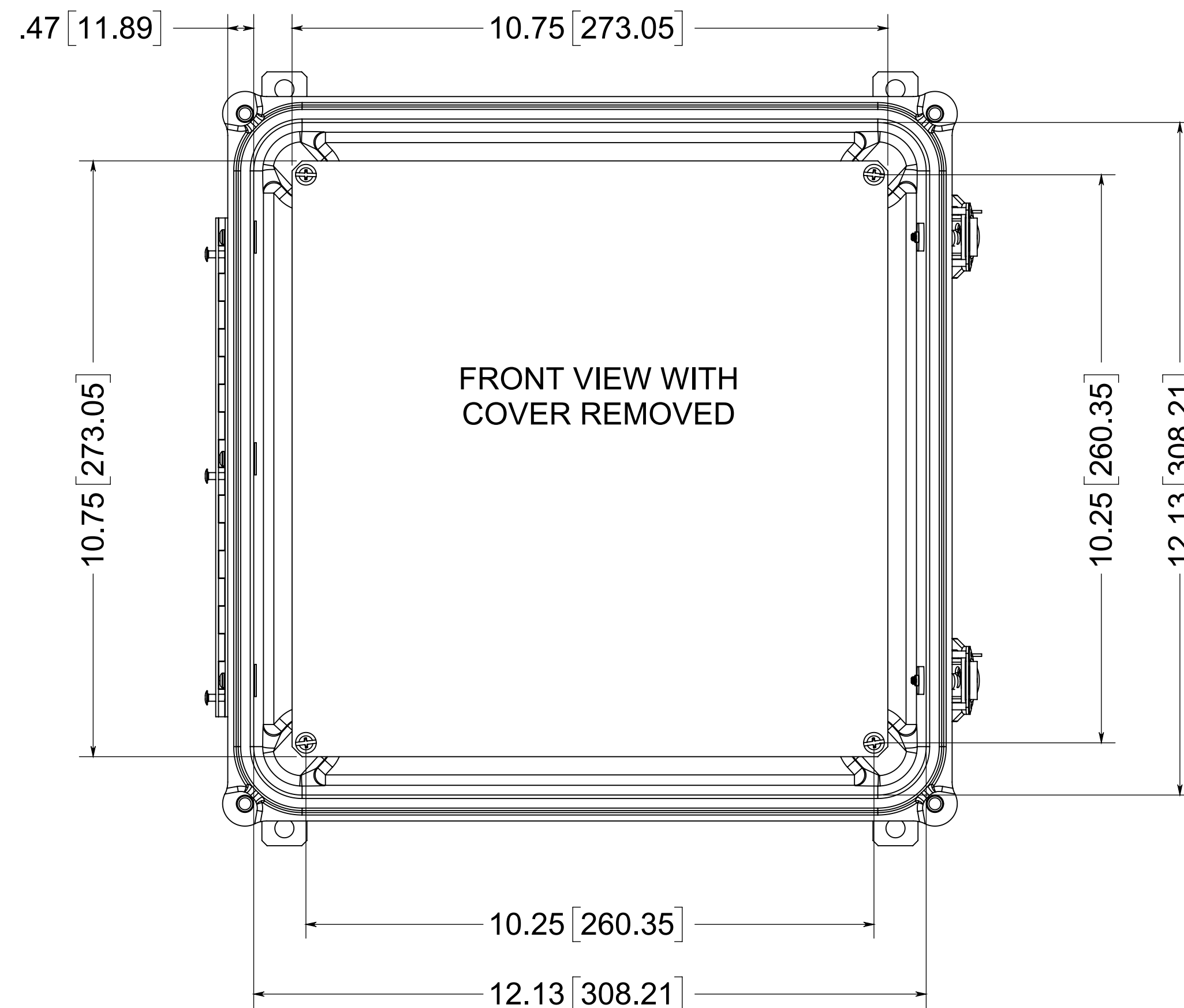

FRONT VIEW WITH COVER REMOVED

MATERIAL:
 BOX- COMPRESSION MOLDED FIBERGLASS REINFORCED POLYESTER
 COVER- COMPRESSION MOLDED FIBERGLASS REINFORCED POLYESTER
 WINDOW- POLYCARBONATE

NOTES:
 1. DATA SUBJECT TO CHANGE WITHOUT NOTICE

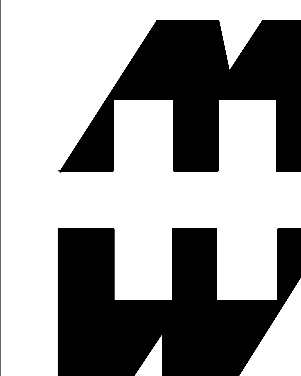

PART No. PJ12126RTW

for more information visit
www.hammfg.com
 Data subject to change without notice
 Drawing Not to Scale