

SECTION B-B

(4X) 316 STAINLESS STEEL FEET

(4X) EACH #10-32 BRASS INSERTS, AND 316 STAINLESS STEEL FEET SCREWS

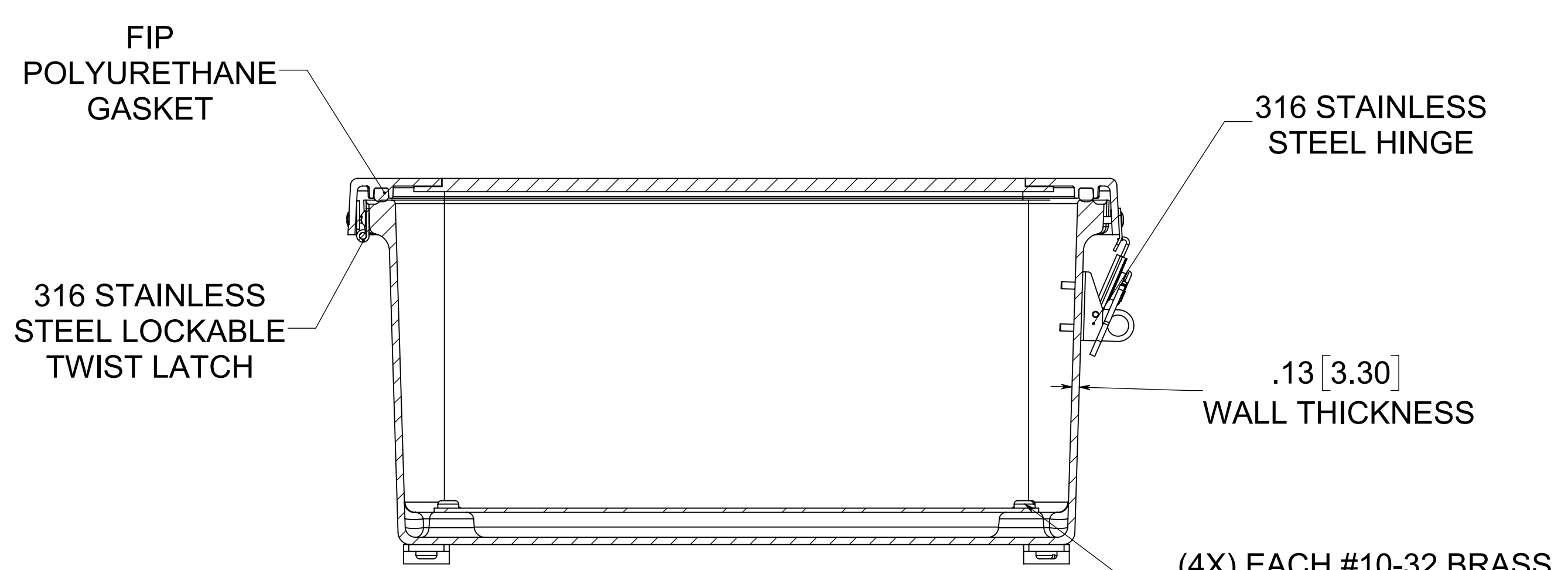
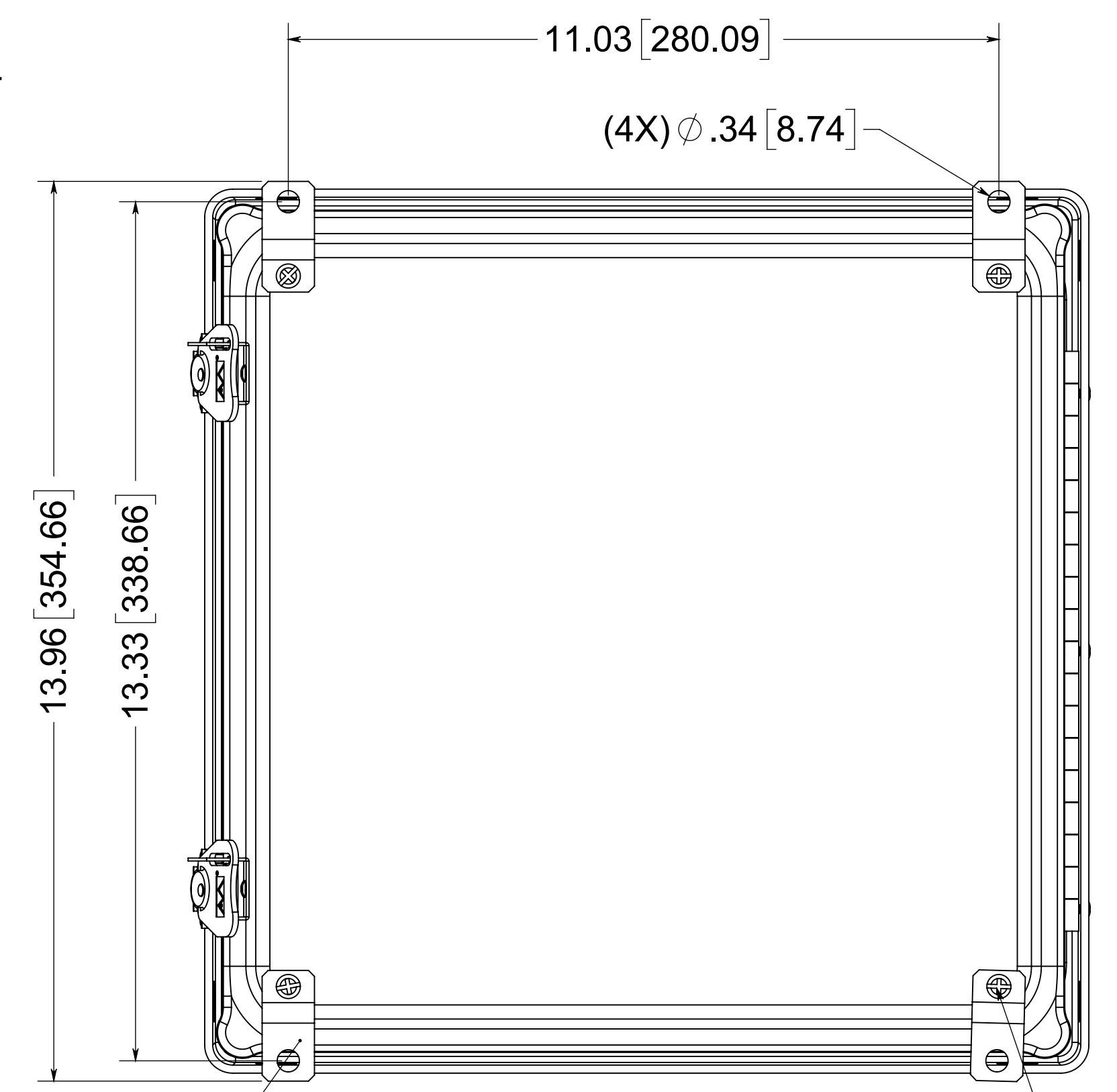

SECTION A-A

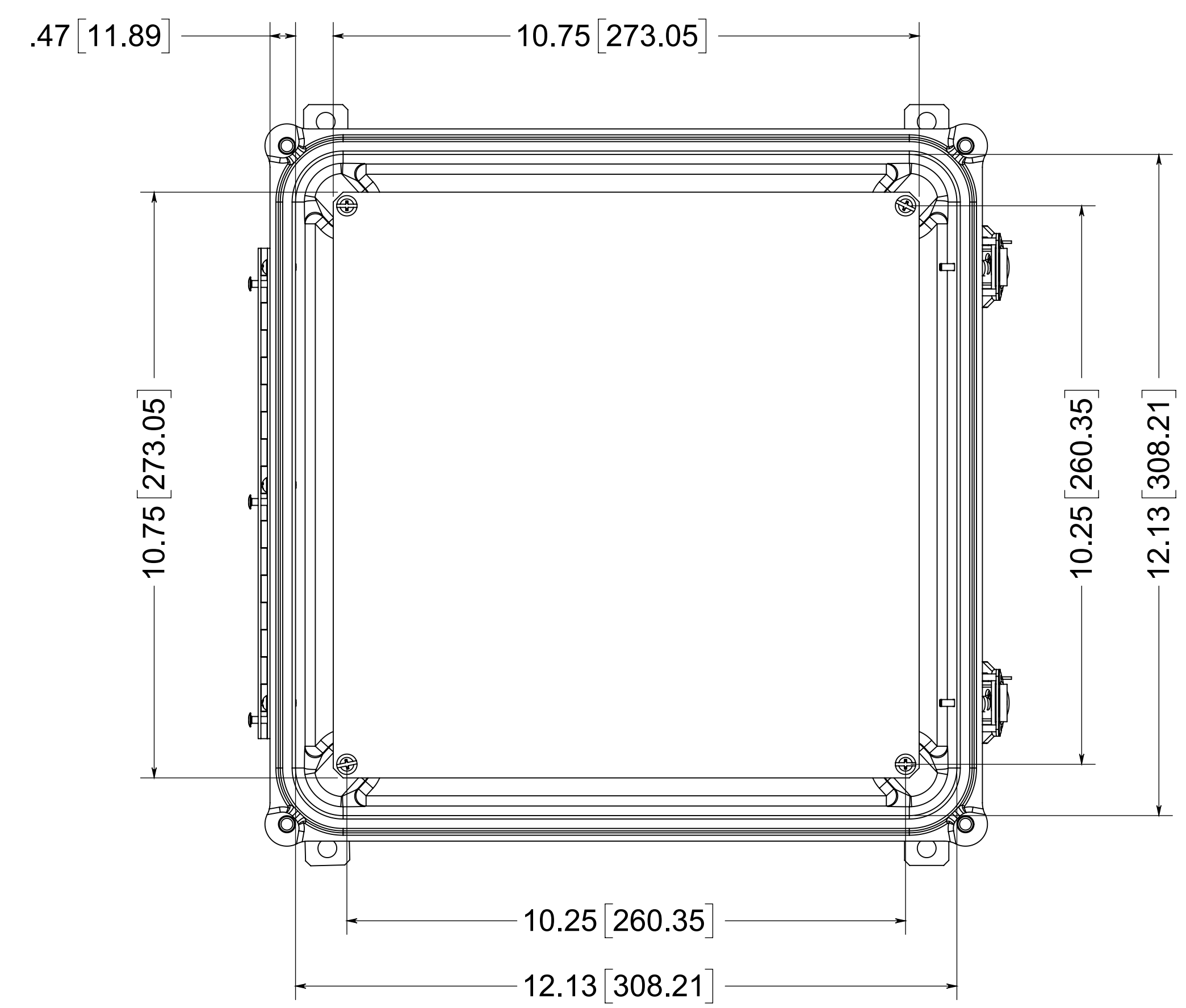

NOTES;  
 1. DATA SUBJECT TO CHANGE WITHOUT NOTICE

MATERIAL:  
 BOX- COMPRESSION MOLDED FIBERGLASS REINFORCED POLYESTER  
 COVER- COPRESSION MOLDED FIBERGLASS REINFORCED POLYESTER  
 WINDOWS- POLYCARBONATE

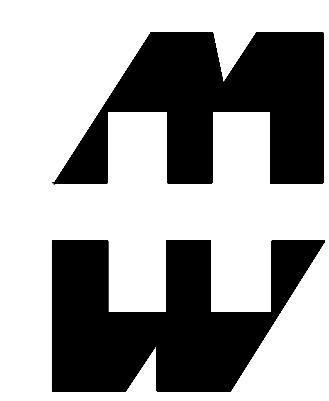

PART No. PJ12126TW

for more information visit  
[www.hammfg.com](http://www.hammfg.com)  
 Data subject to change without notice  
 Drawing Not to Scale