

(4X) EACH #10-32 BRASS INSERTS AND 316 STAINLESS STEEL CAPTIVE COVER SCREWS WITH RETAINING O-RING

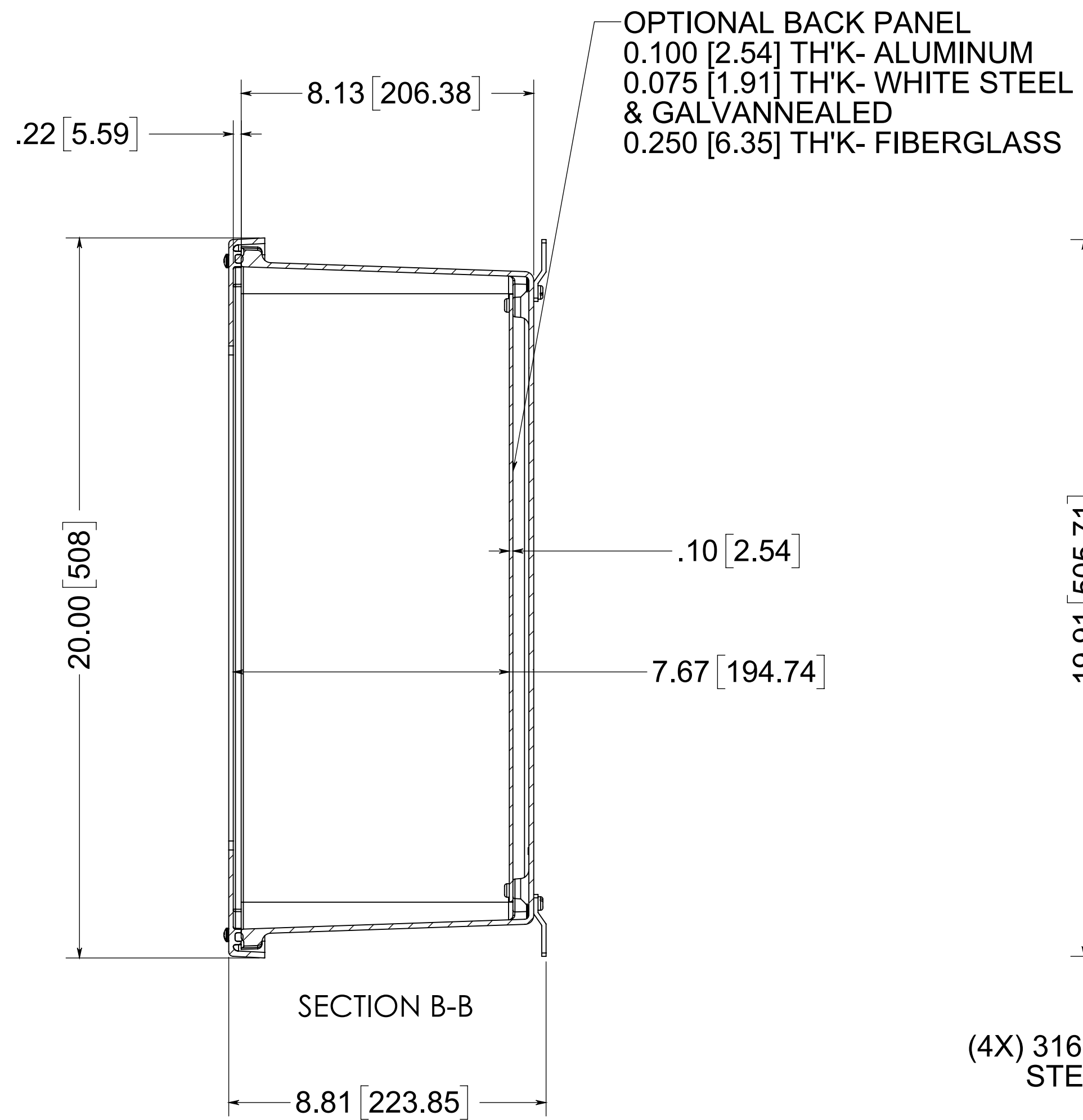

(4X) 316 STAINLESS STEEL FEET

(4X) EACH #10-32 BRASS INSERTS, AND 316 STAINLESS STEEL FEET SCREWS

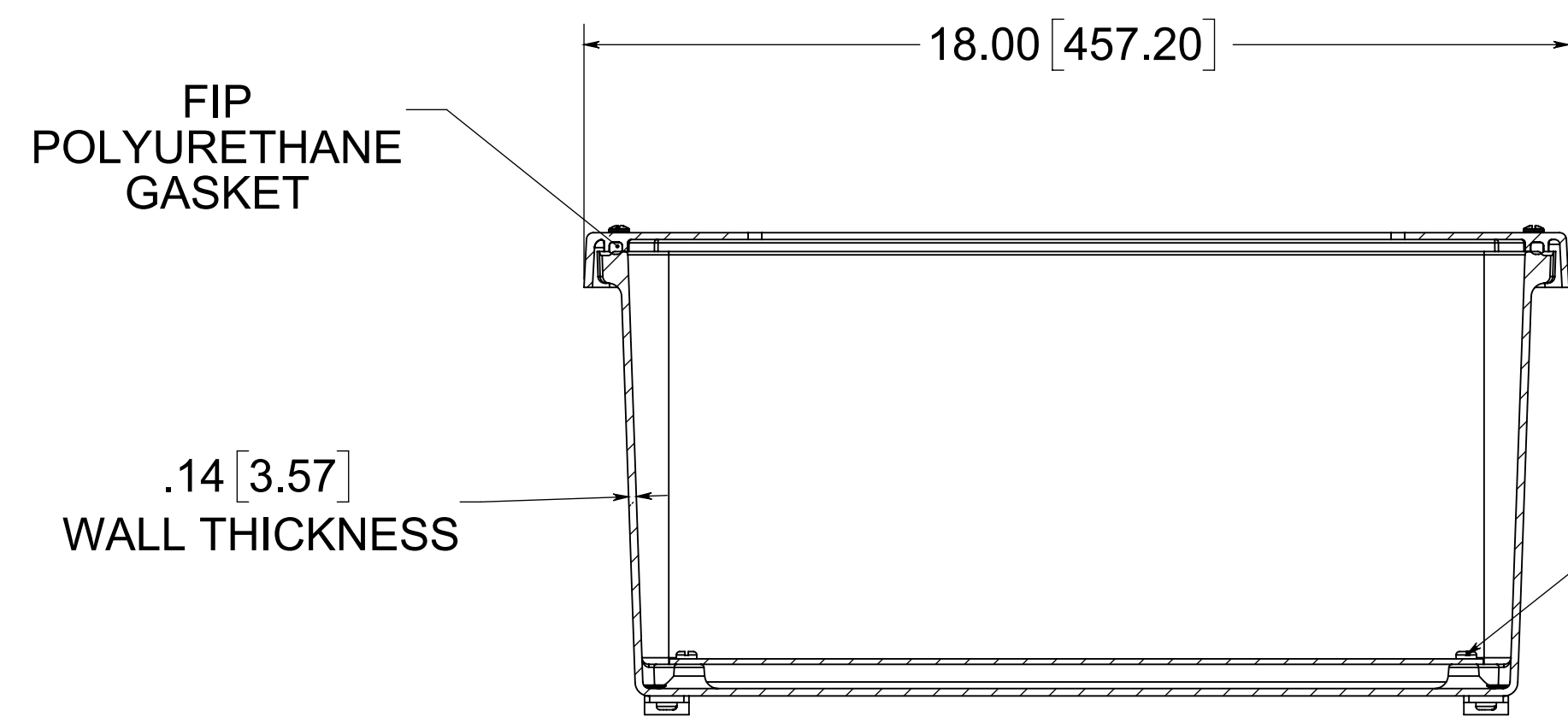

SECTION A-A

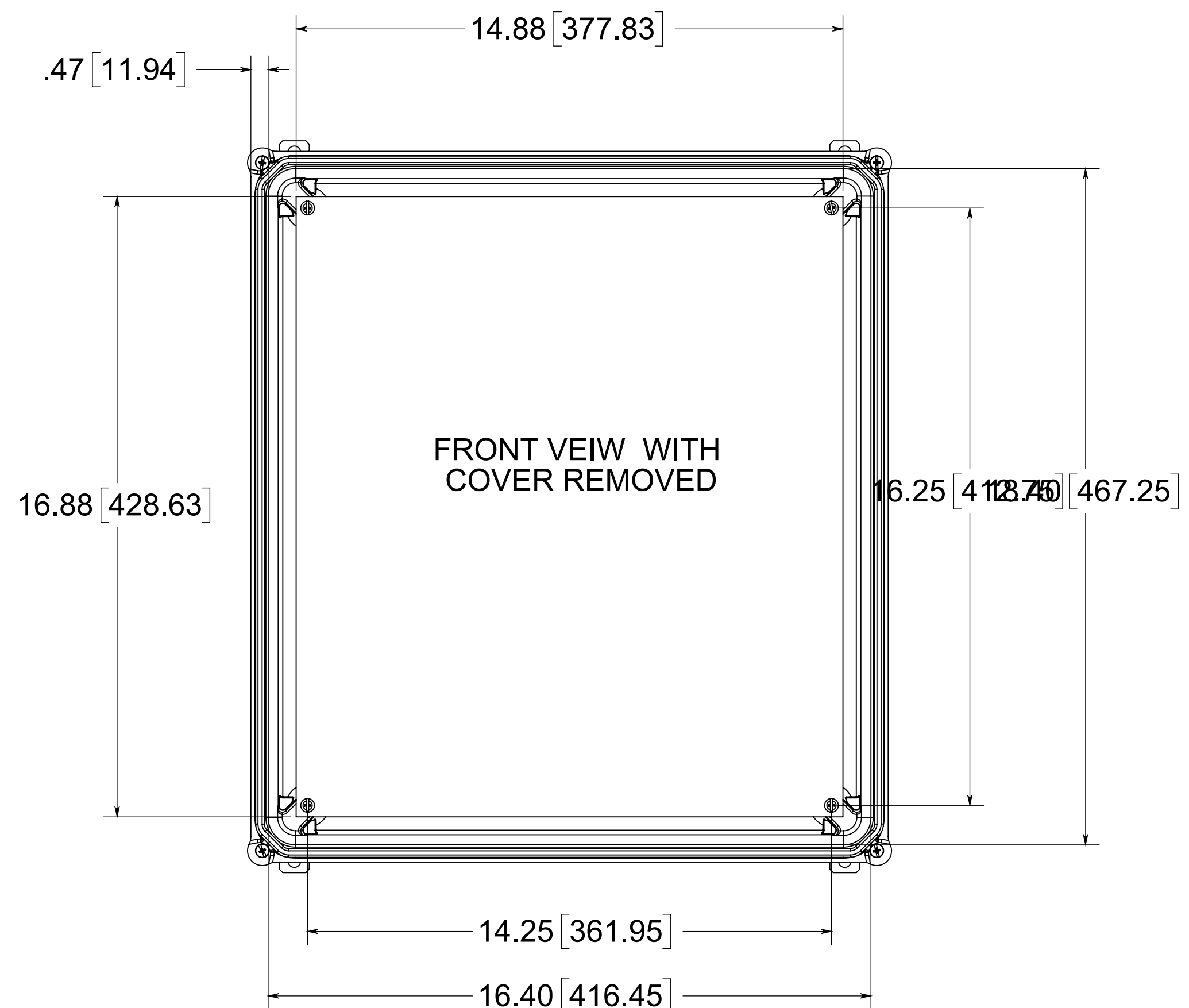

NOTE:
1. DATA SUBJECT TO CHANGE WITHOUT NOTICE

MATERIAL:
BOX- COMPRESSION MOLDED FIBERGLASS REINFORCED POLYESTER
COVER- COMPRESSION MOLDED FIBERGLASS REINFORCED POLYESTER
WINDOWS- POLYCARBONATE

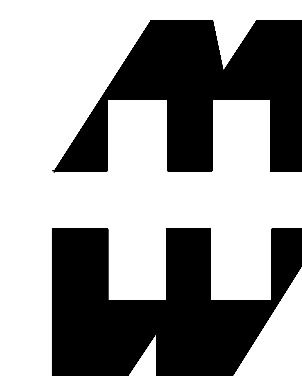

PART No. PJ18168W

for more information visit
www.hammfg.com

Data subject to change without notice

Drawing Not to Scale