

Date	Rev	Description	ECN No.	DR	CK	REL
10/24/19		INITIAL RELEASE				
-	-	-	-	-	-	-
-	-	-	-	-	-	-

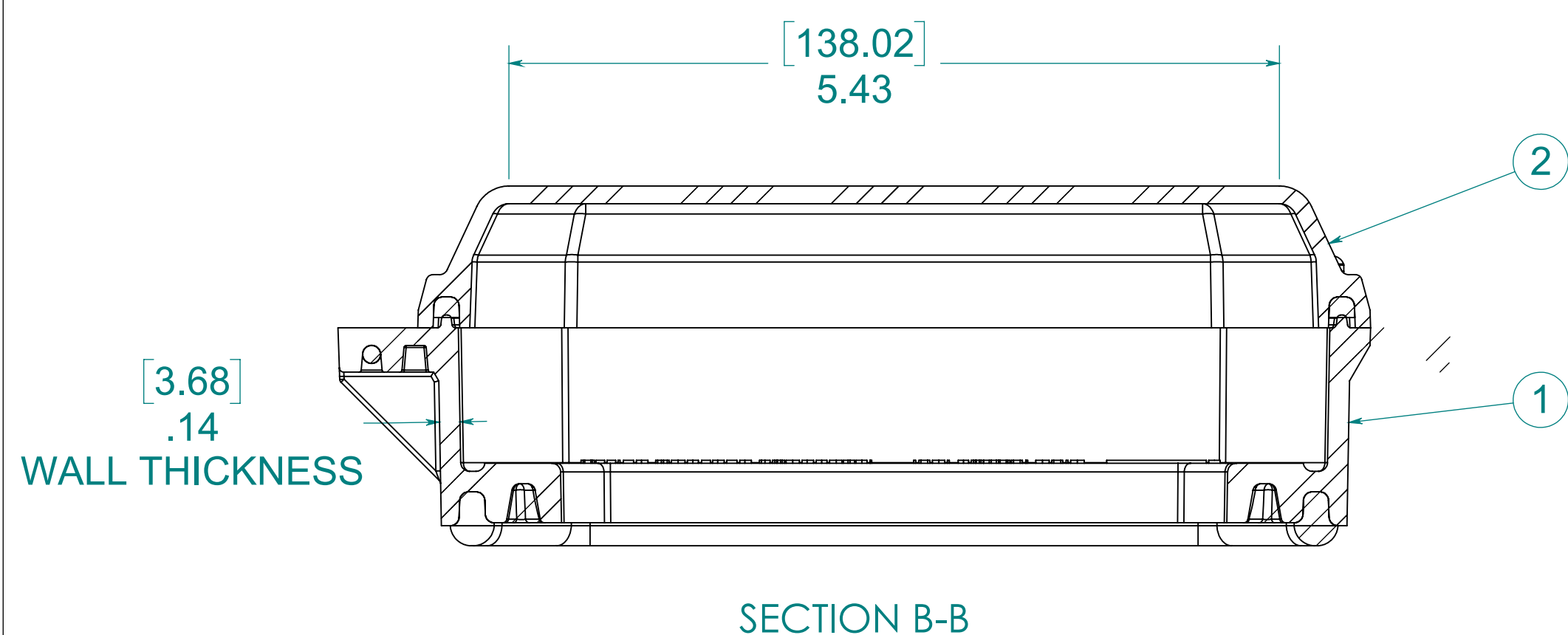

SECTION A-A

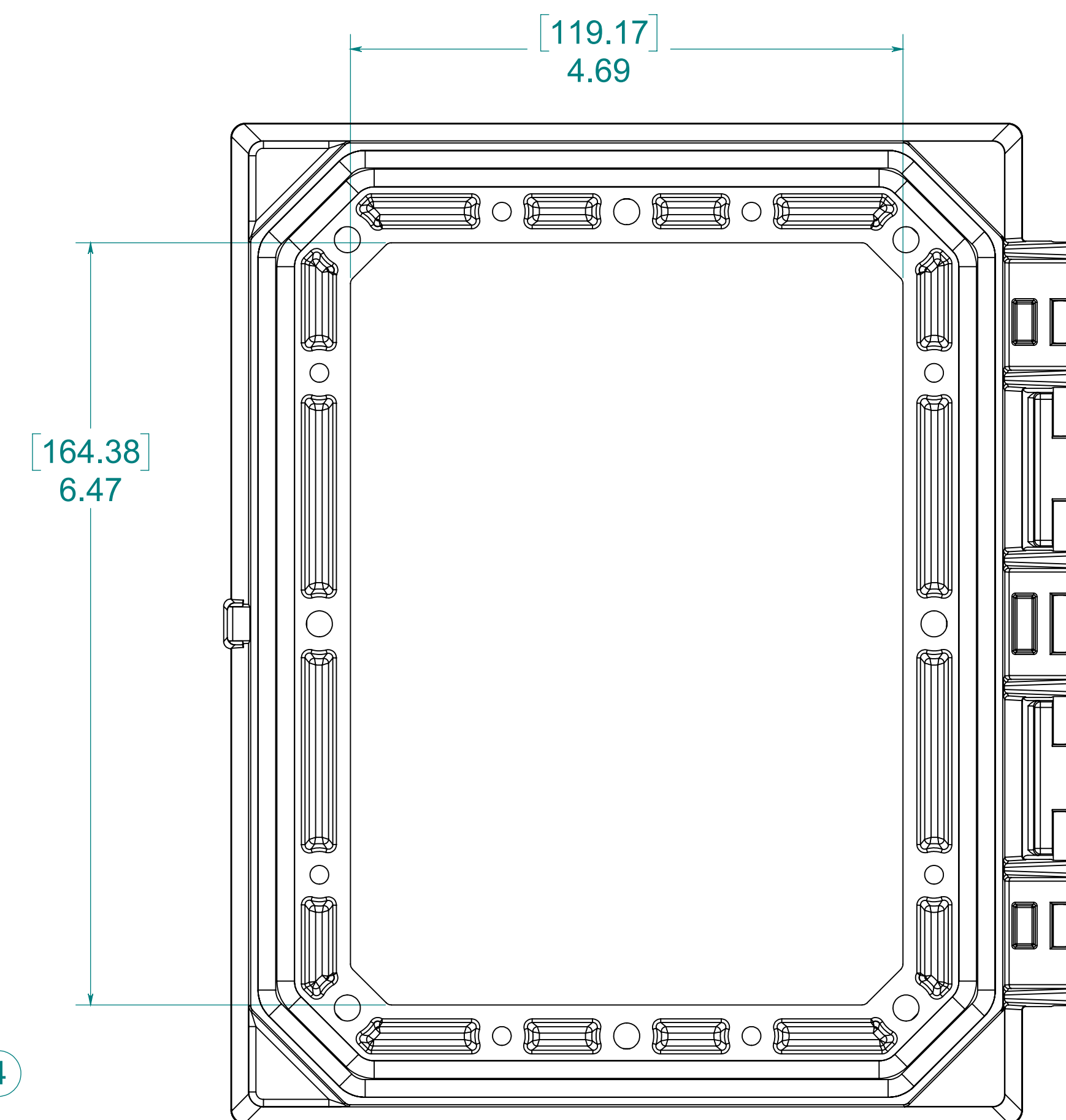
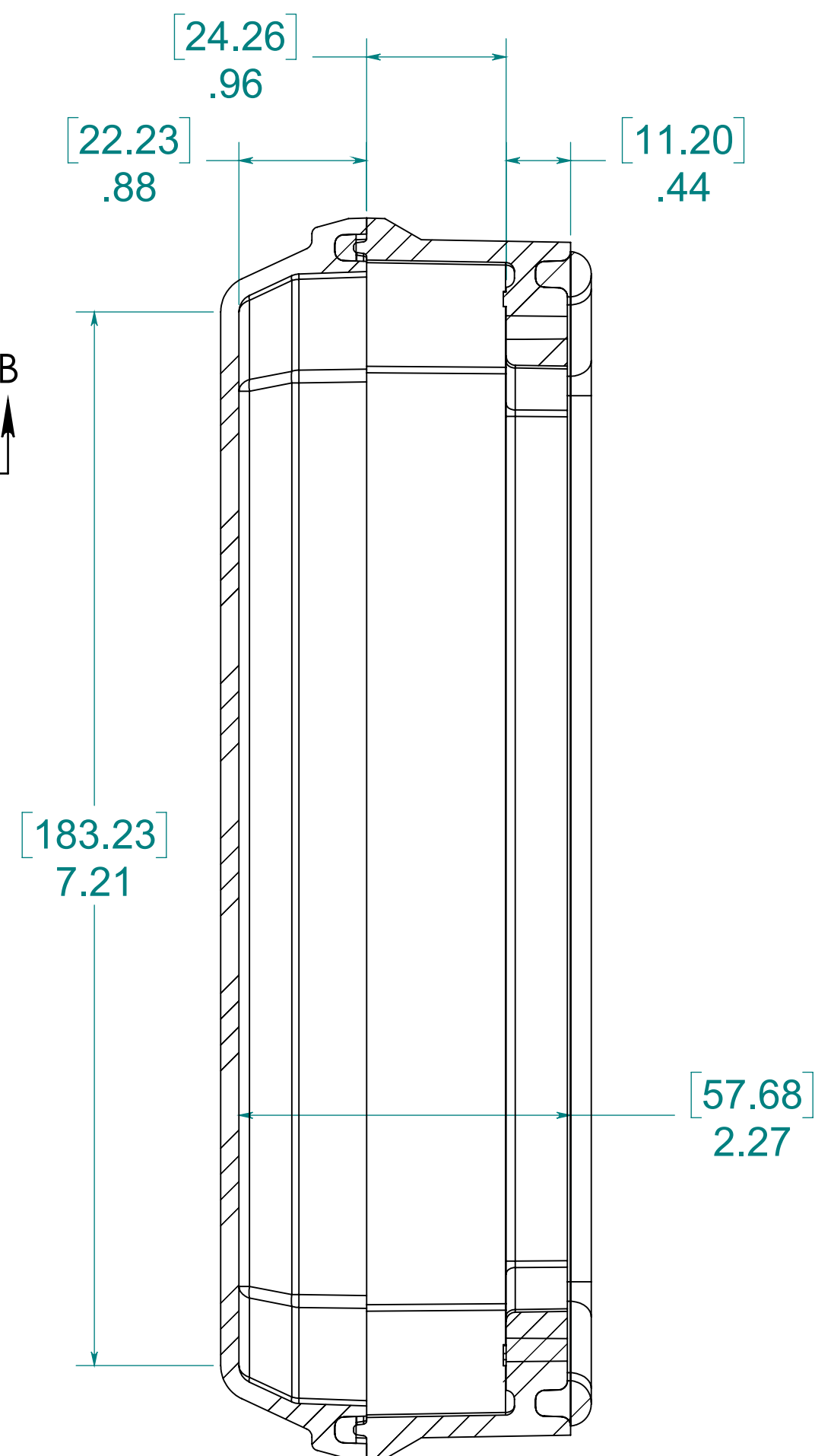
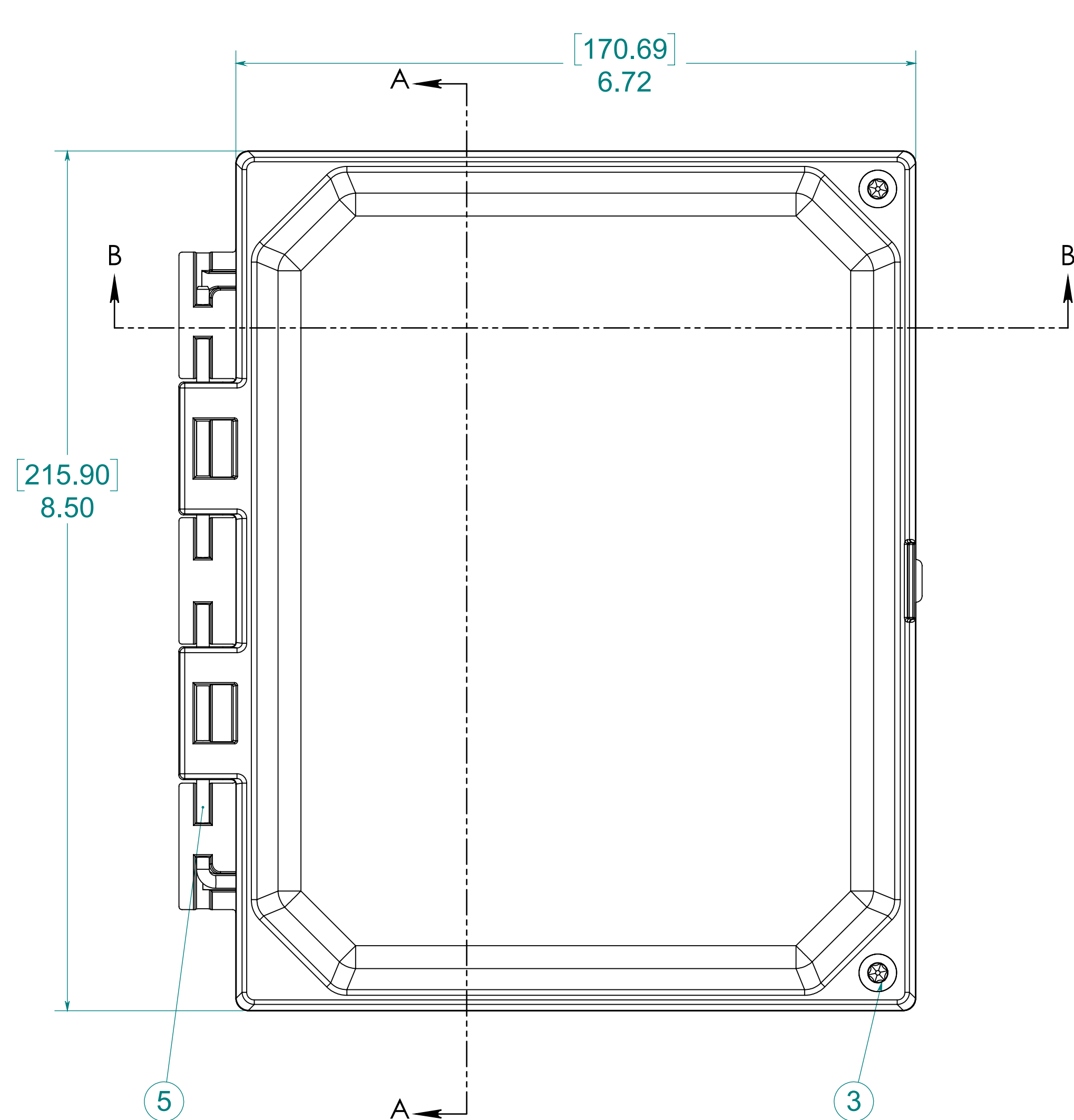
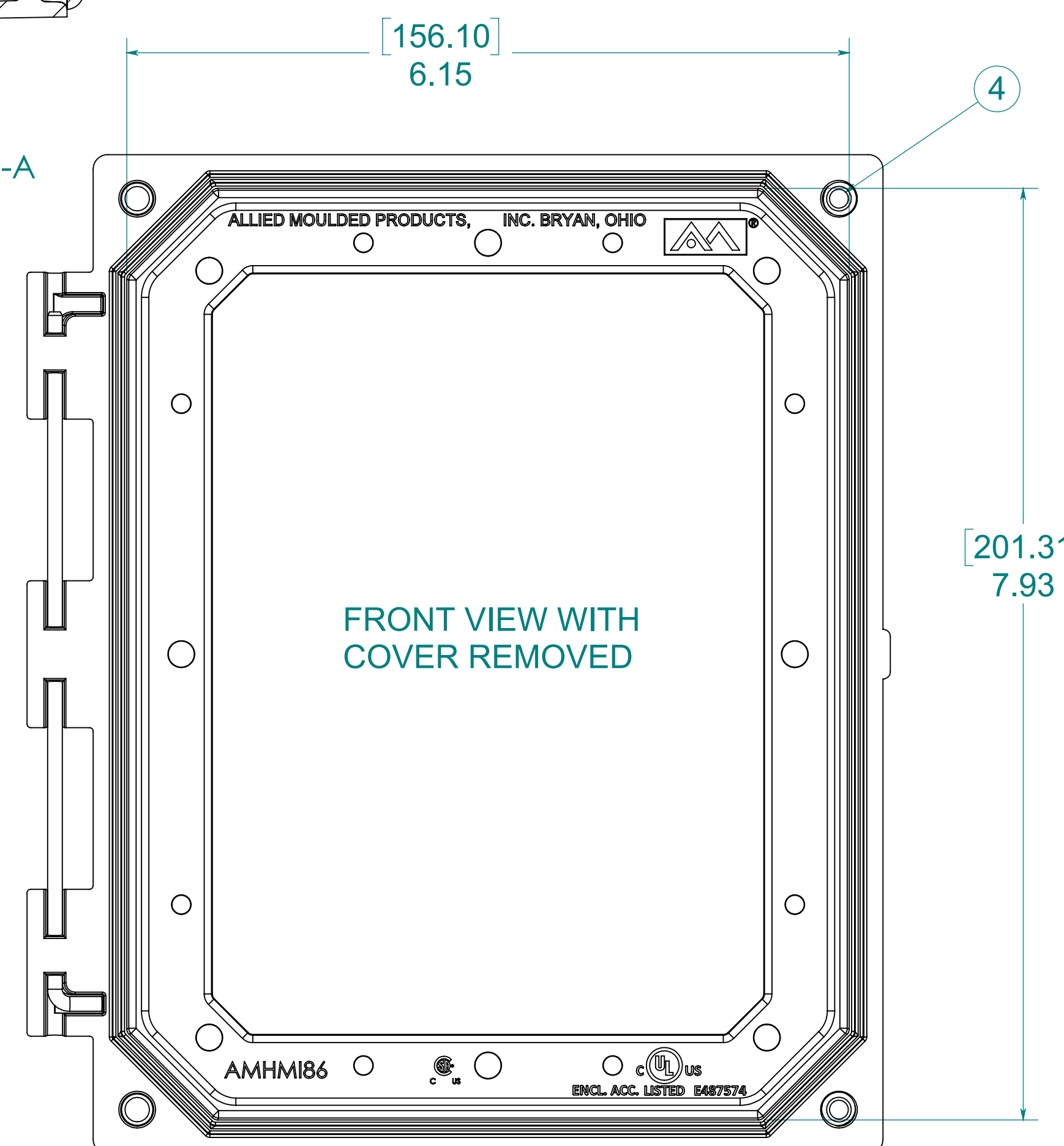

ITEM NO.	PART NUMBER	DESCRIPTION	QTY.
1	WGF86	WIP FIP 86 HMI FRAME	1
2	WGP86C	WIP FIP CVR POLY OPAQUE	1
3	CMSO316TP	TAMPER PROOF SCREW WITH O-RING	2
4	70-60250	#10-32 THREADED INSERT	2
5	70-HPIN8316	HINGE PIN	1

MATERIAL:  
 FRAME- INJECTED POLYCARBONATE  
 STANDARD COVER- INJECTED POLYCARBONATE  
 CLEAR COVER- INJECTED POLYCARBONATE

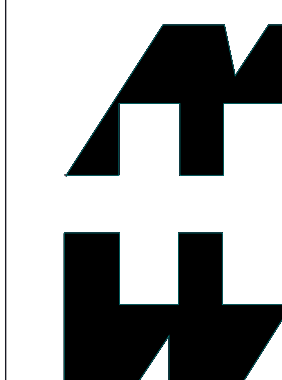

PART No. PJHMI86HTP

for more information visit  
[www.hammfg.com](http://www.hammfg.com)  
 Data subject to change without notice

Drawing Not to Scale