

(2X) EACH #10-32 BRASS INSERTS AND 316 STAINLESS CAPTIVE COVER SCREWS

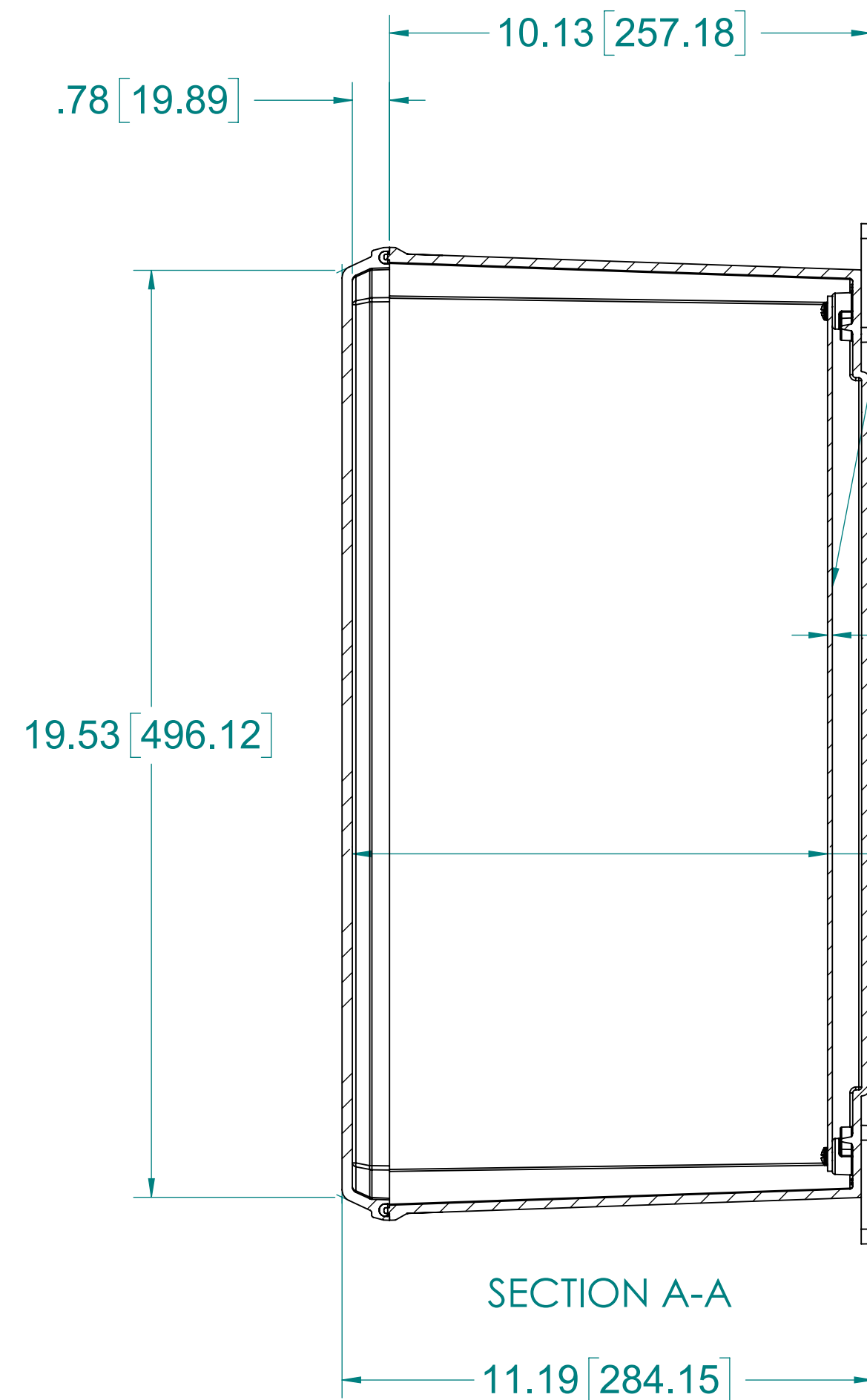

SECTION A-A

OPTIONAL BACK PANEL  
 0.100 [2.54] TH'K - ALUMINUM  
 0.075 [1.91] TH'K - WHITE STEEL & GALVANNEALED  
 0.250 [6.35] TH'K - FIBERGLASS

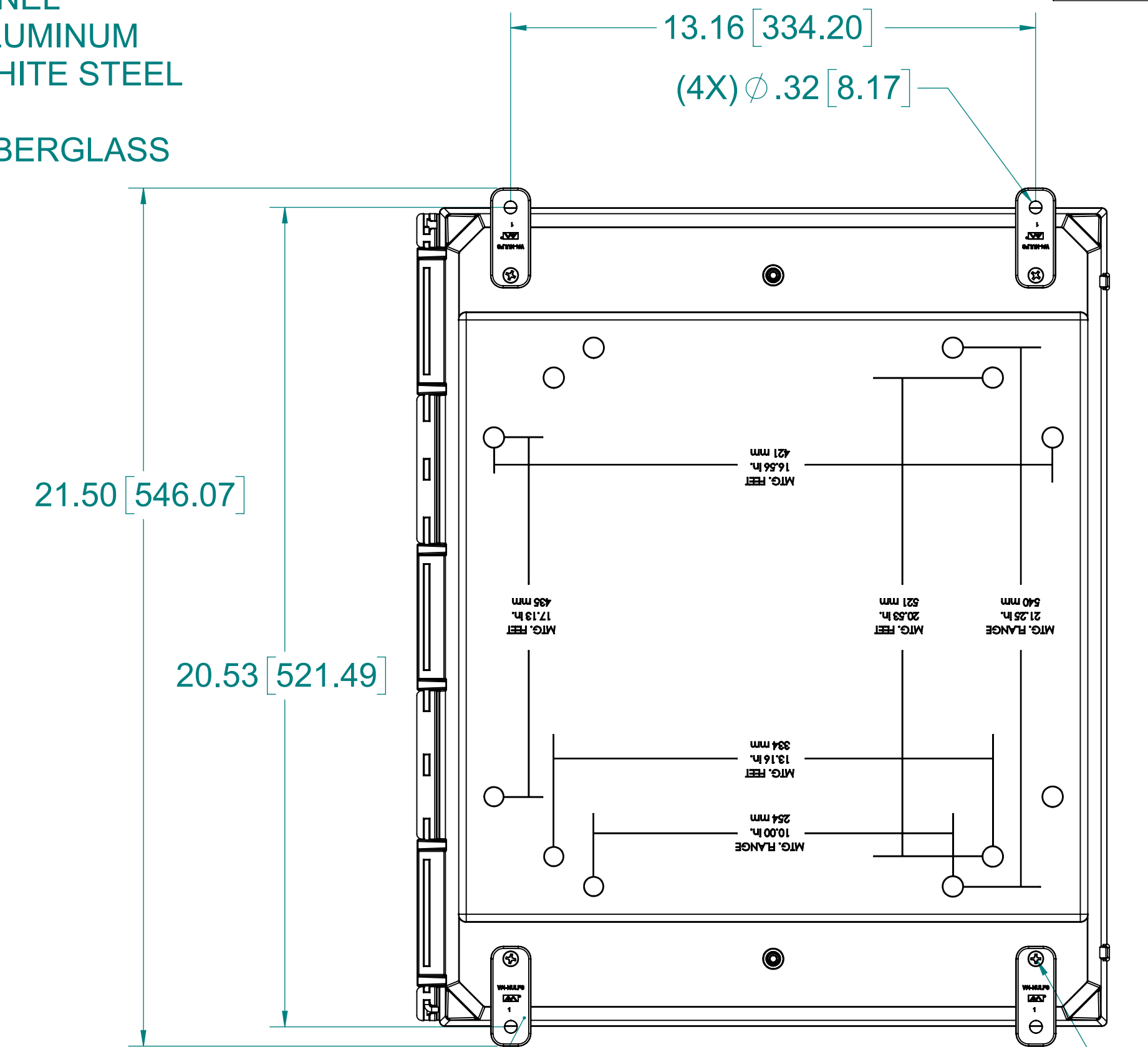

(2X) POLYCARBONATE FEET

(4X) EACH #10-32 BRASS INSERTS AND 316 STAINLESS STEEL FLANGE AND FEET SCREWS

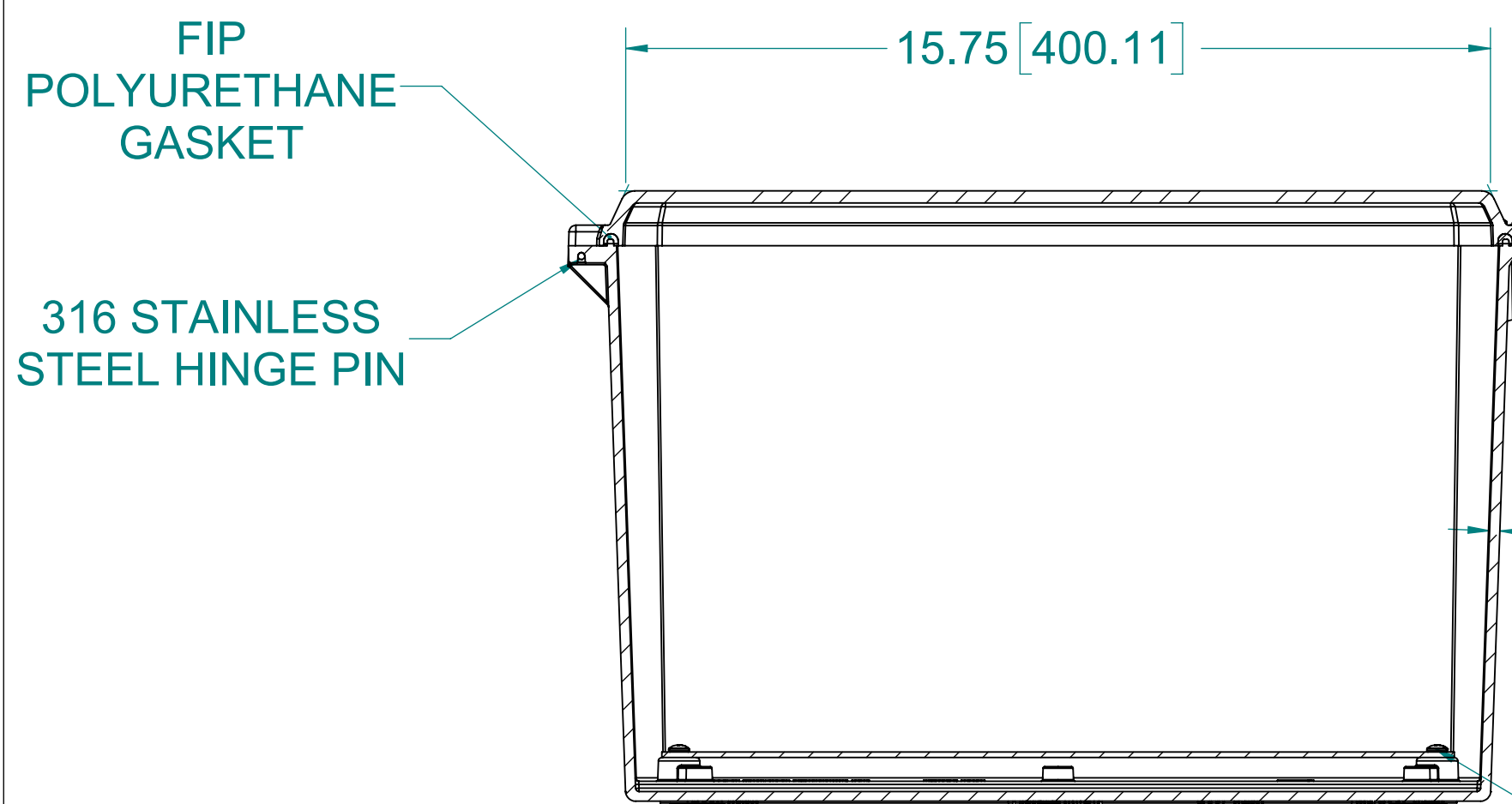

SECTION B-B

(4X) EACH #10-32 BRASS INSERTS AND PLATED CARBON STEEL SCREWS

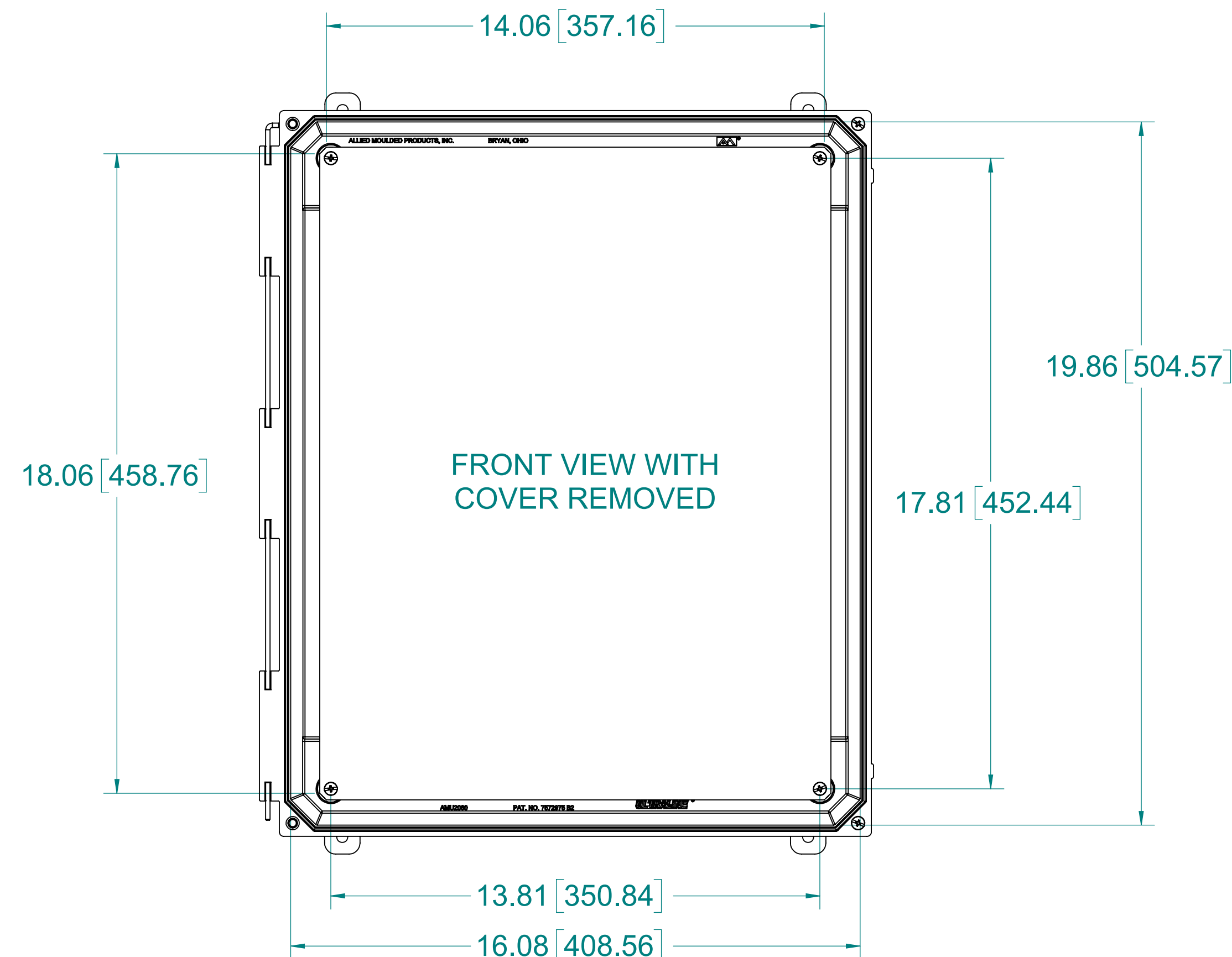

FRONT VIEW WITH COVER REMOVED

NOTE:  
 1. DATA SUBJECT TO CHANGE

MATERIAL:  
 BOX: INJECTION MOLDED POLYCARBONATE  
 STANDARD COVER: INJECTION MOLDED POLYCARBONATE  
 CLEAR COVER: INJECTION MOLDED POLYCARBONATE

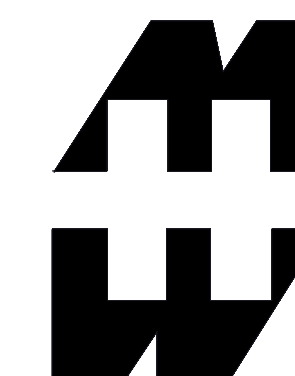

PART No.  
 PJU201610CCH.WEB  
 for more information visit  
[www.hammfg.com](http://www.hammfg.com)  
 Data subject to change without notice  
 Drawing Not to Scale