

Enclosures can be Factory Modified (Milling, Drilling, Printing etc.)
 Contact Factory (modshop@hammondmfg.com) for quotes
 Solid models of this enclosure available in .stp or .x_t
 (Part number and text placement/orientation on our products are subject to change,
 we do not recommend using them as a locating reference for modification purposes)

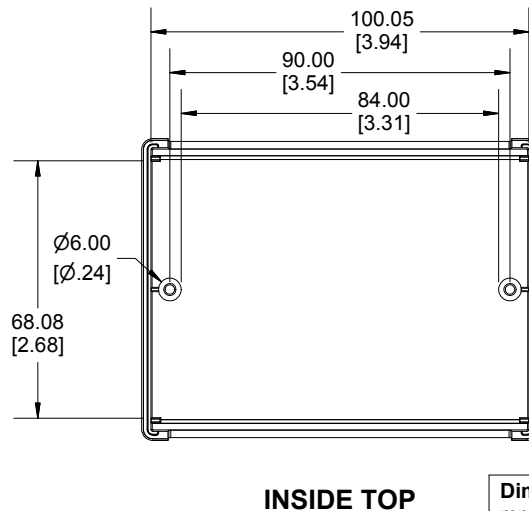
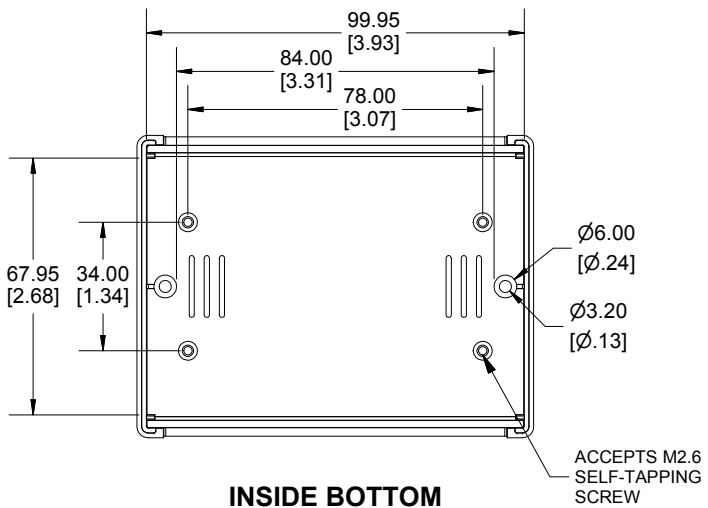

NOTE	
Purchased assembly includes box, lid, 2 end panels, 4 PCB screws, and 2 lid screws.	
Enclosure molded from GPABS Plastic	
Recommended Torque : (43-50) Ozf.in / (30-35) cN.m	

RM Enclosure	
General Purpose ABS Light Grey (UL94 HB)	RM2005M
General Purpose ABS Translucent Black (UL94 HB)	RM2005MTBK
ACCESSORIES	
Lid Screw (M3X20mm Self-tapping)	SC616-50
PCB Screw (M2.6 X6mm Self-tapping)	SC519-50
Folding Feet Kit	FT-01

**HAMMOND
MANUFACTURING**

RM2005M
www.hammondmfg.com

Dimensions:
mm
[inches]