

**TOP VIEW**

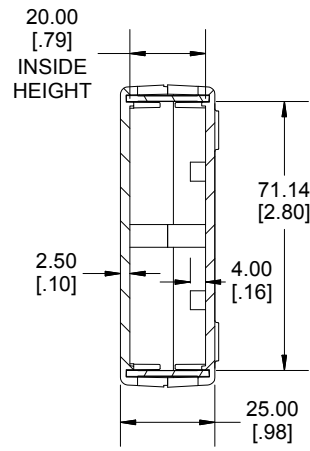

**SECTION A-A**

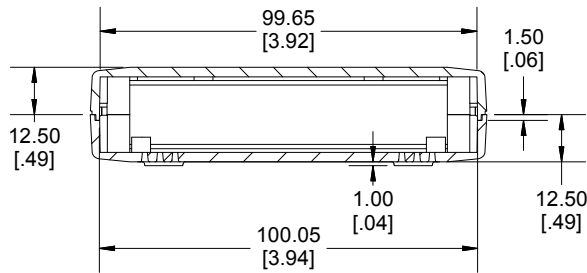
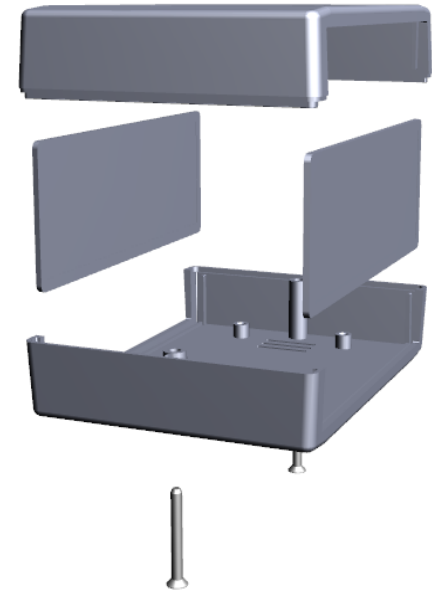

**SECTION B-B  
END VIEW**

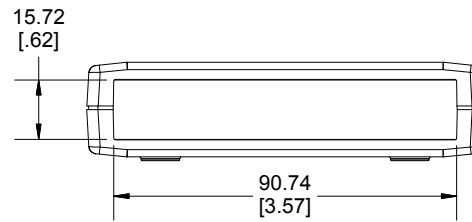

**END VIEW**

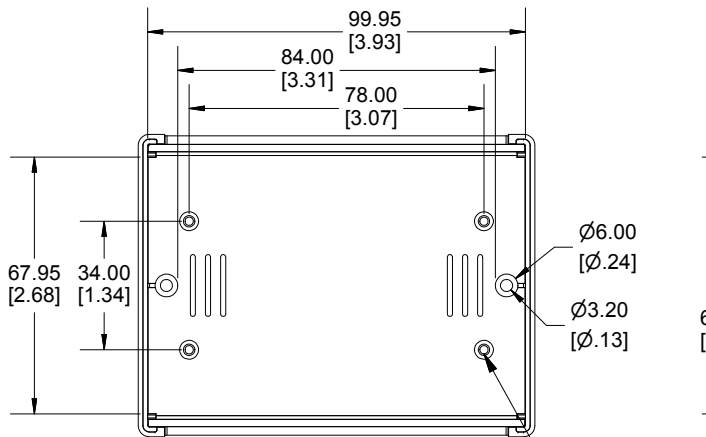

**INSIDE BOTTOM**

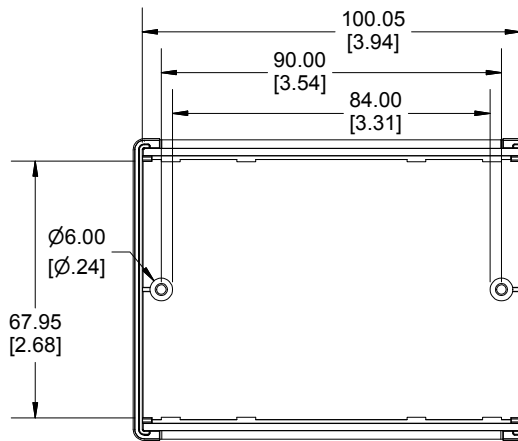

**INSIDE TOP**

ACCEPTS M2.6  
SELF-TAPPING  
SCREW

Enclosures can be Factory Modified (Milling, Drilling, Printing etc.)  
Contact Factory ([modshop@hammondmfg.com](mailto:modshop@hammondmfg.com)) for quotes  
Solid models of this enclosure available in .stp or .x\_t  
(Part number and text placement/orientation on our products are subject to change,  
we do not recommend using them as a locating reference for modification purposes)

<b>NOTE</b>	
Purchased assembly includes box, lid, 2 end panels, 4 PCB screws, and 2 lid screws.	
Enclosure molded from GPABS Plastic	
Recommended Torque : (43-50) Ozf.in / (30-35) cN.m	

<b>RM Enclosure</b>	
General Purpose ABS Light Grey (UL94 HB)	RM2005S
General Purpose ABS Translucent Black (UL94 HB)	RM2005STBK
<b>ACCESSORIES</b>	
Lid Screw (M3X 20mm Self-tapping)	SC616-50
PCB Screw (M2.6 X 6mm Self-tapping)	SC519-50
Folding Feet Kit	FT-01

**HAMMOND  
MANUFACTURING**

**RM2005S**

[www.hammondmfg.com](http://www.hammondmfg.com)

Dimensions:  
mm  
[inches]